

FINAL JEE-MAIN EXAMINATION – JANUARY, 2024

(Held On Monday 29th January, 2024)

TIME : 3 : 00 PM to 6 : 00 PM

MATHEMATICS

TEST PAPER WITH SOLUTION

SECTION-A

1. Let $A = \begin{bmatrix} 2 & 1 & 2 \\ 6 & 2 & 11 \\ 3 & 3 & 2 \end{bmatrix}$ and $P = \begin{bmatrix} 1 & 2 & 0 \\ 5 & 0 & 2 \\ 7 & 1 & 5 \end{bmatrix}$. The sum

of the prime factors of $|P^{-1}AP - 2I|$ is equal to

- (1) 26 (2) 27 (3) 66 (4) 23

Ans. (1)

Sol. $|P^{-1}AP - 2I| = |P^{-1}AP - 2P^{-1}P|$
 $= |P^{-1}(A - 2I)P|$
 $= |P^{-1}||A - 2I||P|$
 $= |A - 2I|$
 $= \begin{vmatrix} 0 & 1 & 2 \\ 6 & 0 & 11 \\ 3 & 3 & 0 \end{vmatrix} = 69$

So, Prime factor of 69 is 3 & 23

So, sum = 26

2. Number of ways of arranging 8 identical books into 4 identical shelves where any number of shelves may remain empty is equal to

- (1) 18 (2) 16 (3) 12 (4) 15

Ans. (4)

Sol. 3 Shelf empty : (8, 0, 0, 0) → 1 way

2 shelf empty : $\left. \begin{matrix} (7,1,0,0) \\ (6,2,0,0) \\ (5,3,0,0) \\ (4,4,0,0) \end{matrix} \right\} \rightarrow 4 \text{ways}$

1 shelf empty : $\left. \begin{matrix} (6,1,1,0) & (3,3,2,0) \\ (5,2,1,0) & (4,2,2,0) \\ (4,3,1,0) \end{matrix} \right\} \rightarrow 5 \text{ways}$

0 Shelf empty : $\left. \begin{matrix} (1,2,3,2) & (5,1,1,1) \\ (2,2,2,2) \\ (3,3,1,1) \\ (4,2,1,1) \end{matrix} \right\} \rightarrow 5 \text{ways}$

Total = 15 ways

3. Let P(3, 2, 3), Q (4, 6, 2) and R (7, 3, 2) be the vertices of ΔPQR . Then, the angle $\angle QPR$ is

- (1) $\frac{\pi}{6}$ (2) $\cos^{-1}\left(\frac{7}{18}\right)$
 (3) $\cos^{-1}\left(\frac{1}{18}\right)$ (4) $\frac{\pi}{3}$

Ans. (4)

Sol.

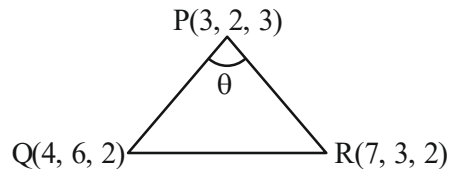

Direction ratio of PR = (4, 1, -1)

Direction ratio of PQ = (1, 4, -1)

Now, $\cos \theta = \frac{|4 + 4 + 1|}{\sqrt{18} \cdot \sqrt{18}}$

$\theta = \frac{\pi}{3}$

4. If the mean and variance of five observations are $\frac{24}{5}$ and $\frac{194}{25}$ respectively and the mean of first

four observations is $\frac{7}{2}$, then the variance of the

first four observations is equal to

- (1) $\frac{4}{5}$ (2) $\frac{77}{12}$ (3) $\frac{5}{4}$ (4) $\frac{105}{4}$

Ans. (3)

Sol. $\bar{X} = \frac{24}{5}; \sigma^2 = \frac{194}{25}$

Let first four observation be x_1, x_2, x_3, x_4

Here, $\frac{x_1 + x_2 + x_3 + x_4 + x_5}{5} = \frac{24}{5} \dots\dots(1)$

Also, $\frac{x_1 + x_2 + x_3 + x_4}{4} = \frac{7}{2}$

$\Rightarrow \boxed{x_1 + x_2 + x_3 + x_4 = 14}$

Now from eqn -1

$$x_5 = 10$$

$$\text{Now, } \sigma^2 = \frac{194}{25}$$

$$\frac{x_1^2 + x_2^2 + x_3^2 + x_4^2 + x_5^2}{5} - \frac{576}{25} = \frac{194}{25}$$

$$\Rightarrow x_1^2 + x_2^2 + x_3^2 + x_4^2 = 54$$

Now, variance of first 4 observations

$$\begin{aligned} \text{Var} &= \frac{\sum_{i=1}^4 x_i^2}{4} - \left(\frac{\sum_{i=1}^4 x_i}{4} \right)^2 \\ &= \frac{54}{4} - \frac{49}{4} = \frac{5}{4} \end{aligned}$$

5. The function $f(x) = 2x + 3(x)^{\frac{2}{3}}, x \in \mathbb{R}$, has

- (1) exactly one point of local minima and no point of local maxima
- (2) exactly one point of local maxima and no point of local minima
- (3) exactly one point of local maxima and exactly one point of local minima
- (4) exactly two points of local maxima and exactly one point of local minima

Ans. (3)

Sol. $f(x) = 2x + 3(x)^{\frac{2}{3}}$

$$f'(x) = 2 + 2x^{-\frac{1}{3}}$$

$$= 2 \left(1 + \frac{1}{x^{\frac{1}{3}}} \right)$$

$$= 2 \left(\frac{x^{\frac{1}{3}} + 1}{x^{\frac{1}{3}}} \right)$$

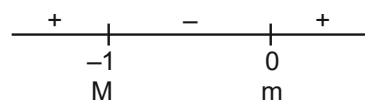

So, maxima (M) at $x = -1$ & minima (m) at $x = 0$

6. Let r and θ respectively be the modulus and amplitude of the complex number

$$z = 2 - i \left(2 \tan \frac{5\pi}{8} \right), \text{ then } (r, \theta) \text{ is equal to}$$

(1) $\left(2 \sec \frac{3\pi}{8}, \frac{3\pi}{8} \right)$

(2) $\left(2 \sec \frac{3\pi}{8}, \frac{5\pi}{8} \right)$

(3) $\left(2 \sec \frac{5\pi}{8}, \frac{3\pi}{8} \right)$

(4) $\left(2 \sec \frac{11\pi}{8}, \frac{11\pi}{8} \right)$

Ans. (1)

Sol. $z = 2 - i \left(2 \tan \frac{5\pi}{8} \right) = x + iy$ (let)

$$r = \sqrt{x^2 + y^2} \quad \& \quad \theta = \tan^{-1} \frac{y}{x}$$

$$r = \sqrt{(2)^2 + \left(2 \tan \frac{5\pi}{8} \right)^2}$$

$$= \left| 2 \sec \frac{5\pi}{8} \right| = \left| 2 \sec \left(\pi - \frac{3\pi}{8} \right) \right|$$

$$= 2 \sec \frac{3\pi}{8}$$

$$\& \quad \theta = \tan^{-1} \left(\frac{-2 \tan \frac{5\pi}{8}}{2} \right)$$

$$= \tan^{-1} \left(\tan \left(\pi - \frac{5\pi}{8} \right) \right)$$

$$= \frac{3\pi}{8}$$

7. The sum of the solutions $x \in \mathbb{R}$ of the equation

$$\frac{3 \cos 2x + \cos^3 2x}{\cos^6 x - \sin^6 x} = x^3 - x^2 + 6 \text{ is}$$

(1) 0 (2) 1

(3) -1 (4) 3

Ans. (3)

Sol.
$$\frac{3\cos 2x + \cos^3 2x}{\cos^6 x - \sin^6 x} = x^3 - x^2 + 6$$

$$\Rightarrow \frac{\cos 2x (3 + \cos^2 2x)}{\cos 2x (1 - \sin^2 x \cos^2 x)} = x^3 - x^2 + 6$$

$$\Rightarrow \frac{4(3 + \cos^2 2x)}{(4 - \sin^2 2x)} = x^3 - x^2 + 6$$

$$\Rightarrow \frac{4(3 + \cos^2 2x)}{(3 + \cos^2 2x)} = x^3 - x^2 + 6$$

$$x^3 - x^2 + 2 = 0 \Rightarrow (x + 1)(x^2 - 2x + 2) = 0$$

so, sum of real solutions = -1

8. Let $\vec{OA} = \vec{a}, \vec{OB} = 12\vec{a} + 4\vec{b}$ and $\vec{OC} = \vec{b}$, where O is the origin. If S is the parallelogram with adjacent sides OA and OC, then

area of the quadrilateral OABC is equal to _____
area of S

- (1) 6 (2) 10
(3) 7 (4) 8

Ans. (4)

Sol.

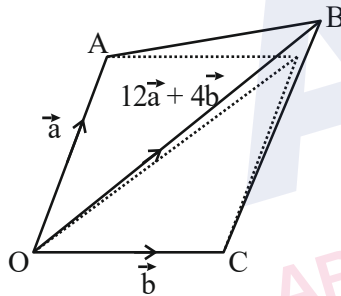

Area of parallelogram, $S = |\vec{a} \times \vec{b}|$

Area of quadrilateral = Area(ΔOAB) + Area(ΔOBC)

$$= \frac{1}{2} \{ |\vec{a} \times (12\vec{a} + 4\vec{b})| + |\vec{b} \times (12\vec{a} + 4\vec{b})| \}$$

$$= 8 |(\vec{a} \times \vec{b})|$$

$$\text{Ratio} = \frac{8 |(\vec{a} \times \vec{b})|}{|(\vec{a} \times \vec{b})|} = 8$$

9. If $\log_e a, \log_e b, \log_e c$ are in an A.P. and $\log_e a - \log_e 2b, \log_e 2b - \log_e 3c, \log_e 3c - \log_e a$ are also in an A.P., then $a : b : c$ is equal to

- (1) 9 : 6 : 4 (2) 16 : 4 : 1
(3) 25 : 10 : 4 (4) 6 : 3 : 2

Ans. (1)

Sol. $\log_e a, \log_e b, \log_e c$ are in A.P.

$$\therefore b^2 = ac \dots (i)$$

Also

$\log_e \left(\frac{a}{2b} \right), \log_e \left(\frac{2b}{3c} \right), \log_e \left(\frac{3c}{a} \right)$ are in A.P.

$$\left(\frac{2b}{3c} \right)^2 = \frac{a}{2b} \times \frac{3c}{a}$$

$$\frac{b}{c} = \frac{3}{2}$$

Putting in eq. (i) $b^2 = a \times \frac{2b}{3}$

$$\frac{a}{b} = \frac{3}{2}$$

$$a : b : c = 9 : 6 : 4$$

10. If

$$\int \frac{\sin^{\frac{3}{2}} x + \cos^{\frac{3}{2}} x}{\sqrt{\sin^3 x \cos^3 x \sin(x - \theta)}} dx = A\sqrt{\cos \theta \tan x - \sin \theta} + B\sqrt{\cos \theta - \sin \theta \cot x} + C,$$

where C is the integration constant, then AB is equal to

- (1) $4 \operatorname{cosec}(2\theta)$ (2) $4 \sec \theta$
(3) $2 \sec \theta$ (4) $8 \operatorname{cosec}(2\theta)$

Ans. (4)

Sol.
$$\int \frac{\sin^{\frac{3}{2}} x + \cos^{\frac{3}{2}} x}{\sqrt{\sin^3 x \cos^3 x \sin(x - \theta)}} dx$$

$$I = \int \frac{\sin^{\frac{3}{2}} x + \cos^{\frac{3}{2}} x}{\sqrt{\sin^3 x \cos^3 x (\sin x \cos \theta - \cos x \sin \theta)}} dx$$

$$= \int \frac{\sin^{\frac{3}{2}} x}{\sin^{\frac{3}{2}} x \cos^2 x \sqrt{\tan x \cos \theta - \sin \theta}} dx + \int \frac{\cos^{\frac{3}{2}} x}{\sin^2 x \cos^{\frac{3}{2}} x \sqrt{\cos \theta - \cot x \sin \theta}} dx =$$

$$\int \frac{\sec^2 x}{\sqrt{\tan x \cos \theta - \sin \theta}} dx + \int \frac{\operatorname{cosec}^2 x}{\sqrt{\cos \theta - \cot x \sin \theta}} dx$$

$$I = I_1 + I_2 \dots \dots \{ \text{Let} \}$$

For I_1 , let $\tan x \cos \theta - \sin \theta = t^2$

$$\sec^2 x dx = \frac{2t dt}{\cos \theta}$$

For I_2 , let $\cos \theta - \cot x \sin \theta = z^2$

$$\operatorname{cosec}^2 x dx = \frac{2z dz}{\sin \theta}$$

$$I = I_1 + I_2$$

$$= \int \frac{2t dt}{\cos \theta t} + \int \frac{2z dz}{\sin \theta z}$$

$$= \frac{2t}{\cos \theta} + \frac{2z}{\sin \theta}$$

$$= 2 \sec \theta \sqrt{\tan x \cos \theta - \sin \theta} + 2 \operatorname{cosec} \theta \sqrt{\cos \theta - \cot x \sin \theta}$$

Comparing

$$AB = 8 \operatorname{cosec} 2\theta$$

11. The distance of the point (2, 3) from the line $2x - 3y + 28 = 0$, measured parallel to the line $\sqrt{3}x - y + 1 = 0$, is equal to

- (1) $4\sqrt{2}$ (2) $6\sqrt{3}$
(3) $3 + 4\sqrt{2}$ (4) $4 + 6\sqrt{3}$

Ans. (4)

Sol.

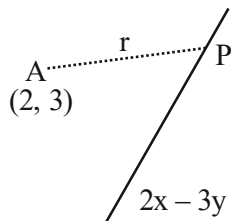

Writing P in terms of parametric co-ordinates $2 + r \cos \theta$, $3 + r \sin \theta$ as $\tan \theta = \sqrt{3}$

$$P\left(2 + \frac{r}{2}, 3 + \frac{\sqrt{3}r}{2}\right)$$

P must satisfy $2x - 3y + 28 = 0$

$$\text{So, } 2\left(2 + \frac{r}{2}\right) - 3\left(3 + \frac{\sqrt{3}r}{2}\right) + 28 = 0$$

We find $r = 4 + 6\sqrt{3}$

12. If $\sin\left(\frac{y}{x}\right) = \log_e |x| + \frac{\alpha}{2}$ is the solution of the

differential equation $x \cos\left(\frac{y}{x}\right) \frac{dy}{dx} = y \cos\left(\frac{y}{x}\right) + x$

and $y(1) = \frac{\pi}{3}$, then α^2 is equal to

- (1) 3 (2) 12
(3) 4 (4) 9

Ans. (1)

Sol. Differential equation :-

$$x \cos \frac{y}{x} \frac{dy}{dx} = y \cos \frac{y}{x} + x$$

$$\cos \frac{y}{x} \left[x \frac{dy}{dx} - y \right] = x$$

Divide both sides by x^2

$$\cos \frac{y}{x} \left(\frac{x \frac{dy}{dx} - y}{x^2} \right) = \frac{1}{x}$$

Let $\frac{y}{x} = t$

$$\cos t \left(\frac{dt}{dx} \right) = \frac{1}{x}$$

$$\cos t dt = \frac{1}{x} dx$$

Integrating both sides

$$\sin t = \ln |x| + c$$

$$\sin \frac{y}{x} = \ln |x| + c$$

Using $y(1) = \frac{\pi}{3}$, we get $c = \frac{\sqrt{3}}{2}$

So, $\alpha = \sqrt{3} \Rightarrow \alpha^2 = 3$

13. If each term of a geometric progression a_1, a_2, a_3, \dots with $a_1 = \frac{1}{8}$ and $a_2 \neq a_1$, is the arithmetic mean of

the next two terms and $S_n = a_1 + a_2 + \dots + a_n$, then $S_{20} - S_{18}$ is equal to

- (1) 2^{15} (2) -2^{18}
(3) 2^{18} (4) -2^{15}

Ans. (4)

Sol. Let r 'th term of the GP be ar^{n-1} . Given,

$$2a_r = a_{r+1} + a_{r+2}$$

$$2ar^{n-1} = ar^n + ar^{n+1}$$

$$\frac{2}{r} = 1 + r$$

$$r^2 + r - 2 = 0$$

Hence, we get, $r = -2$ (as $r \neq 1$)

So, $S_{20} - S_{18} = (\text{Sum upto 20 terms}) - (\text{Sum upto 18 terms}) = T_{19} + T_{20}$

$$T_{19} + T_{20} = ar^{18}(1+r)$$

Putting the values $a = \frac{1}{8}$ and $r = -2$;

we get $T_{19} + T_{20} = -2^{15}$

- 14.** Let A be the point of intersection of the lines $3x + 2y = 14$, $5x - y = 6$ and B be the point of intersection of the lines $4x + 3y = 8$, $6x + y = 5$. The distance of the point P(5, -2) from the line AB is

(1) $\frac{13}{2}$ (2) 8 (3) $\frac{5}{2}$ (4) 6

Ans. (4)

Sol. Solving lines L_1 ($3x + 2y = 14$) and L_2 ($5x - y = 6$) to get A(2, 4) and solving lines L_3 ($4x + 3y = 8$) and L_4 ($6x + y = 5$) to get B($\frac{1}{2}, 2$).

Finding Eqn. of AB : $4x - 3y + 4 = 0$

Calculate distance PM

$$\Rightarrow \left| \frac{4(5) - 3(-2) + 4}{5} \right| = 6$$

- 15.** Let $x = \frac{m}{n}$ (m, n are co-prime natural numbers) be a solution of the equation $\cos(2\sin^{-1}x) = \frac{1}{9}$ and let α, β ($\alpha > \beta$) be the roots of the equation $mx^2 - nx - m + n = 0$. Then the point (α, β) lies on the line

(1) $3x + 2y = 2$ (2) $5x - 8y = -9$
(3) $3x - 2y = -2$ (4) $5x + 8y = 9$

Ans. (4)

Sol. Assume $\sin^{-1}x = \theta$

$$\cos(2\theta) = \frac{1}{9}$$

$$\sin\theta = \pm \frac{2}{3}$$

as m and n are co-prime natural numbers,

$$x = \frac{2}{3}$$

i.e. $m = 2, n = 3$

So, the quadratic equation becomes $2x^2 - 3x + 1 = 0$ whose roots are $\alpha = 1, \beta = \frac{1}{2}$

$(1, \frac{1}{2})$ lies on $5x + 8y = 9$

- 16.** The function $f(x) = \frac{x}{x^2 - 6x - 16}, x \in \mathbb{R} - \{-2, 8\}$
- (1) decreases in $(-2, 8)$ and increases in $(-\infty, -2) \cup (8, \infty)$
(2) decreases in $(-\infty, -2) \cup (-2, 8) \cup (8, \infty)$
(3) decreases in $(-\infty, -2)$ and increases in $(8, \infty)$
(4) increases in $(-\infty, -2) \cup (-2, 8) \cup (8, \infty)$

Ans. (2)

Sol. $f(x) = \frac{x}{x^2 - 6x - 16}$

Now,

$$f'(x) = \frac{-(x^2 + 16)}{(x^2 - 6x - 16)^2}$$

$$f'(x) < 0$$

Thus $f(x)$ is decreasing in

$$(-\infty, -2) \cup (-2, 8) \cup (8, \infty)$$

- 17.** Let $y = \log_e \left(\frac{1-x^2}{1+x^2} \right), -1 < x < 1$. Then at $x = \frac{1}{2}$,

the value of $225(y' - y'')$ is equal to

(1) 732 (2) 746
(3) 742 (4) 736

Ans. (4)

Sol. $y = \log_e \left(\frac{1-x^2}{1+x^2} \right)$

$$\frac{dy}{dx} = y' = \frac{-4x}{1-x^4}$$

Again,

$$\frac{d^2y}{dx^2} = y'' = \frac{-4(1+3x^4)}{(1-x^4)^2}$$

Again

$$y' - y'' = \frac{-4x}{1-x^4} + \frac{4(1+3x^4)}{(1-x^4)^2}$$

at $x = \frac{1}{2}$,

$$y' - y'' = \frac{736}{225}$$

$$\text{Thus } 225(y' - y'') = 225 \times \frac{736}{225} = 736$$

18. If R is the smallest equivalence relation on the set $\{1, 2, 3, 4\}$ such that $\{(1,2), (1,3)\} \subset R$, then the number of elements in R is _____

- (1) 10 (2) 12
(3) 8 (4) 15

Ans. (1)

Sol. Given set $\{1, 2, 3, 4\}$

Minimum order pairs are

$(1, 1), (2, 2), (3, 3), (4, 4), (3, 1), (2, 1), (2, 3), (3, 2), (1, 3), (1, 2)$

Thus no. of elements = 10

19. An integer is chosen at random from the integers 1, 2, 3, ..., 50. The probability that the chosen integer is a multiple of atleast one of 4, 6 and 7 is

- (1) $\frac{8}{25}$ (2) $\frac{21}{50}$
(3) $\frac{9}{50}$ (4) $\frac{14}{25}$

Ans. (2)

Sol. Given set = $\{1, 2, 3, \dots, 50\}$

$P(A)$ = Probability that number is multiple of 4

$P(B)$ = Probability that number is multiple of 6

$P(C)$ = Probability that number is multiple of 7

Now,

$$P(A) = \frac{12}{50}, P(B) = \frac{8}{50}, P(C) = \frac{7}{50}$$

again

$$P(A \cap B) = \frac{4}{50}, P(B \cap C) = \frac{1}{50}, P(A \cap C) = \frac{1}{50}$$

$$P(A \cap B \cap C) = 0$$

Thus

$$P(A \cup B \cup C) = \frac{12}{50} + \frac{8}{50} + \frac{7}{50} - \frac{4}{50} - \frac{1}{50} - \frac{1}{50} + 0 = \frac{21}{50}$$

20. Let a unit vector $\hat{u} = x\hat{i} + y\hat{j} + z\hat{k}$ make angles $\frac{\pi}{2}, \frac{\pi}{3}$

and $\frac{2\pi}{3}$ with the vectors $\frac{1}{\sqrt{2}}\hat{i} + \frac{1}{\sqrt{2}}\hat{k}, \frac{1}{\sqrt{2}}\hat{j} + \frac{1}{\sqrt{2}}\hat{k}$

and $\frac{1}{\sqrt{2}}\hat{i} + \frac{1}{\sqrt{2}}\hat{j}$ respectively. If

$\vec{v} = \frac{1}{\sqrt{2}}\hat{i} + \frac{1}{\sqrt{2}}\hat{j} + \frac{1}{\sqrt{2}}\hat{k}$, then $|\hat{u} - \vec{v}|^2$ is equal to

- (1) $\frac{11}{2}$ (2) $\frac{5}{2}$
(3) 9 (4) 7

Ans. (2)

Sol. Unit vector $\hat{u} = x\hat{i} + y\hat{j} + z\hat{k}$

$$\vec{p}_1 = \frac{1}{\sqrt{2}}\hat{i} + \frac{1}{\sqrt{2}}\hat{k}, \vec{p}_2 = \frac{1}{\sqrt{2}}\hat{j} + \frac{1}{\sqrt{2}}\hat{k}$$

$$\vec{p}_3 = \frac{1}{\sqrt{2}}\hat{i} + \frac{1}{\sqrt{2}}\hat{j}$$

Now angle between \hat{u} and $\vec{p}_1 = \frac{\pi}{2}$

$$\hat{u} \cdot \vec{p}_1 = 0 \Rightarrow \frac{x}{\sqrt{2}} + \frac{z}{\sqrt{2}} = 0$$

$$\Rightarrow x + z = 0 \dots (i)$$

Angle between \hat{u} and $\vec{p}_2 = \frac{\pi}{3}$

$$\hat{u} \cdot \vec{p}_2 = |\hat{u}| \cdot |\vec{p}_2| \cos \frac{\pi}{3}$$

$$\Rightarrow \frac{y}{\sqrt{2}} + \frac{z}{\sqrt{2}} = \frac{1}{2} \Rightarrow y + z = \frac{1}{\sqrt{2}} \dots (ii)$$

Angle between \hat{u} and $\vec{p}_3 = \frac{2\pi}{3}$

$$\hat{u} \cdot \vec{p}_3 = |\hat{u}| \cdot |\vec{p}_3| \cos \frac{2\pi}{3}$$

$$\Rightarrow \frac{x}{\sqrt{2}} + \frac{4}{\sqrt{2}} = \frac{-1}{2} \Rightarrow x + y = \frac{-1}{\sqrt{2}} \dots (iii)$$

from equation (i), (ii) and (iii) we get

$$x = \frac{-1}{\sqrt{2}} \quad y = 0 \quad z = \frac{1}{\sqrt{2}}$$

$$\text{Thus } \hat{u} - \hat{v} = \frac{-1}{\sqrt{2}}\hat{i} + \frac{1}{\sqrt{2}}\hat{k} - \frac{1}{\sqrt{2}}\hat{i} - \frac{1}{\sqrt{2}}\hat{j} - \frac{1}{\sqrt{2}}\hat{k}$$

$$\hat{u} - \hat{v} = \frac{-2}{\sqrt{2}}\hat{i} - \frac{1}{\sqrt{2}}\hat{j}$$

$$\therefore |\hat{u} - \hat{v}|^2 = \left(\sqrt{\frac{4}{2} + \frac{1}{2}}\right)^2 = \frac{5}{2}$$

SECTION-B

- 21.** Let α, β be the roots of the equation $x^2 - \sqrt{6}x + 3 = 0$ such that $\text{Im}(\alpha) > \text{Im}(\beta)$. Let a, b be integers not divisible by 3 and n be a natural number such that $\frac{\alpha^{99}}{\beta} + \alpha^{98} = 3^n(a + ib), i = \sqrt{-1}$. Then $n + a + b$ is equal to _____.

Ans. 49

Sol. $x^2 - \sqrt{6}x + 6 = 0 \Rightarrow \alpha, \beta$

$$x = \frac{\sqrt{6} \pm i\sqrt{6}}{2} = \frac{\sqrt{6}}{2}(1 \pm i)$$

$$\alpha = \sqrt{3}(e^{i\frac{\pi}{4}}), \beta = \sqrt{3}(e^{-i\frac{\pi}{4}})$$

$$\therefore \frac{\alpha^{99}}{\beta} + \alpha^{98} = \alpha^{98} \left(\frac{\alpha}{\beta} + 1 \right)$$

$$= \frac{\alpha^{98}(\alpha + \beta)}{\beta} = 3^{49} \left(e^{i\frac{99\pi}{4}} \right) \times \sqrt{2}$$

$$= 3^{49}(-1 + i)$$

$$= 3^n(a + ib)$$

$$\therefore n = 49, a = -1, b = 1$$

$$\therefore n + a + b = 49 - 1 + 1 = 49$$

- 22.** Let for any three distinct consecutive terms a, b, c of an A.P, the lines $ax + by + c = 0$ be concurrent at the point P and $Q(\alpha, \beta)$ be a point such that the system of equations
- $$x + y + z = 6,$$
- $$2x + 5y + \alpha z = \beta \text{ and}$$
- $$x + 2y + 3z = 4, \text{ has infinitely many solutions.}$$
- Then $(PQ)^2$ is equal to _____.

Ans. 113

Sol. $\therefore a, b, c$ and in A.P

$$\Rightarrow 2b = a + c \Rightarrow a - 2b + c = 0$$

$\therefore ax + by + c$ passes through fixed point $(1, -2)$

$$\therefore P = (1, -2)$$

For infinite solution,

$$D = D_1 = D_2 = D_3 = 0$$

$$D: \begin{vmatrix} 1 & 1 & 1 \\ 2 & 5 & \alpha \\ 1 & 2 & 3 \end{vmatrix} = 0$$

$$\Rightarrow \alpha = 8$$

$$D_1: \begin{vmatrix} 6 & 1 & 1 \\ \beta & 5 & \alpha \\ 4 & 2 & 3 \end{vmatrix} = 0 \Rightarrow \beta = 6$$

$$\therefore Q = (8, 6)$$

$$\therefore PQ^2 = 113$$

- 23.** Let $P(\alpha, \beta)$ be a point on the parabola $y^2 = 4x$. If P also lies on the chord of the parabola $x^2 = 8y$ whose mid point is $\left(1, \frac{5}{4}\right)$. Then $(\alpha - 28)(\beta - 8)$ is equal to _____.

Ans. 192

Sol. Parabola is $x^2 = 8y$

Chord with mid point (x_1, y_1) is $T = S_1$

$$\therefore xx_1 - 4(y + y_1) = x_1^2 - 8y_1$$

$$\therefore (x_1, y_1) = \left(1, \frac{5}{4}\right)$$

$$\Rightarrow x - 4\left(y + \frac{5}{4}\right) = 1 - 8 \times \frac{5}{4} = -9$$

$$\therefore x - 4y + 4 = 0 \dots\dots (i)$$

(α, β) lies on (i) & also on $y^2 = 4x$

$$\therefore \alpha - 4\beta + 4 = 0 \dots\dots (ii)$$

$$\& \beta^2 = 4\alpha \dots\dots (iii)$$

Solving (ii) & (iii)

$$\beta^2 = 4(4\beta - 4) \Rightarrow \beta^2 - 16\beta + 16 = 0$$

$$\therefore \beta = 8 \pm 4\sqrt{3} \text{ and } \alpha = 4\beta - 4 = 28 \pm 16\sqrt{3}$$

$$\therefore (\alpha, \beta) = (28 + 16\sqrt{3}, 8 + 4\sqrt{3}) \quad \&$$

$$(28 - 16\sqrt{3}, 8 - 4\sqrt{3})$$

$$\therefore (\alpha - 28)(\beta - 8) = (\pm 16\sqrt{3})(\pm 4\sqrt{3})$$

$$= 192$$

24. If $\int_{\frac{\pi}{6}}^{\frac{\pi}{3}} \sqrt{1 - \sin 2x} dx = \alpha + \beta\sqrt{2} + \gamma\sqrt{3}$, where α, β

and γ are rational numbers, then $3\alpha + 4\beta - \gamma$ is equal to _____.

Ans. 6

Sol. $= \int_{\frac{\pi}{6}}^{\frac{\pi}{3}} \sqrt{1 - \sin 2x} dx$

$$= \int_{\frac{\pi}{6}}^{\frac{\pi}{3}} |\sin x - \cos x| dx$$

$$= \int_{\frac{\pi}{6}}^{\frac{\pi}{4}} (\cos x - \sin x) dx + \int_{\frac{\pi}{4}}^{\frac{\pi}{3}} (\sin x - \cos x) dx$$

$$= -1 + 2\sqrt{2} - \sqrt{3}$$

$$= \alpha + \beta\sqrt{2} + \gamma\sqrt{3}$$

$$\alpha = -1, \beta = 2, \gamma = -1$$

$$3\alpha + 4\beta - \gamma = 6$$

25. Let the area of the region $\{(x, y): 0 \leq x \leq 3, 0 \leq y \leq \min\{x^2 + 2, 2x + 2\}\}$ be A. Then $12A$ is equal to _____.

Ans. 164

Sol.

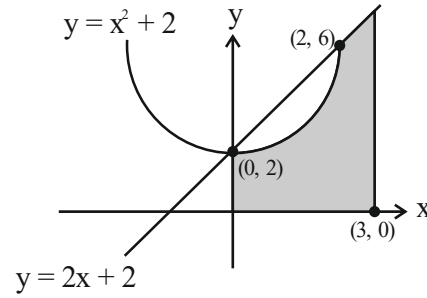

$$A = \int_0^2 (x^2 + 2) dx + \int_2^3 (2x + 2) dx$$

$$A = \frac{41}{3}$$

$$12A = 41 \times 4 = 164$$

26. Let O be the origin, and M and N be the points on the lines $\frac{x-5}{4} = \frac{y-4}{1} = \frac{z-5}{3}$ and $\frac{x+8}{12} = \frac{y+2}{5} = \frac{z+11}{9}$ respectively such that MN is the shortest distance between the given lines. Then $\overrightarrow{OM} \cdot \overrightarrow{ON}$ is equal to _____.

Ans. 9

Sol. $L_1: \frac{x-5}{4} = \frac{y-4}{1} = \frac{z-5}{3} = \lambda$ $\text{dirs } (4, 1, 3) = b_1$

$$M(4\lambda + 5, \lambda + 4, 3\lambda + 5)$$

$$L_2: \frac{x+8}{12} = \frac{y+2}{5} = \frac{z+11}{9} = \mu$$

$$N(12\mu - 8, 5\mu - 2, 9\mu - 11)$$

$$\overrightarrow{MN} = (4\lambda - 12\mu + 13, \lambda - 5\mu + 6, 3\lambda - 9\mu + 16) \dots(1)$$

Now

$$\vec{b}_1 \times \vec{b}_2 = \begin{vmatrix} \hat{i} & \hat{j} & \hat{k} \\ 4 & 1 & 3 \\ 12 & 5 & 9 \end{vmatrix} = -6\hat{i} + 8\hat{k} \dots(2)$$

Equation (1) and (2)

$$\therefore \frac{4\lambda - 12\mu + 13}{-6} = \frac{\lambda - 5\mu + 6}{0} = \frac{3\lambda - 9\mu + 16}{8}$$

I and II

$$\lambda - 5\mu + 6 = 0 \dots(3)$$

I and III

$$\lambda - 3\mu + 4 = 0 \dots(4)$$

Solve (3) and (4) we get

$$\lambda = -1, \mu = 1$$

$$\therefore M(1, 3, 2)$$

$$N(4, 3, -2)$$

$$\therefore \overrightarrow{OM} \cdot \overrightarrow{ON} = 4 + 9 - 4 = 9$$

27. Let $f(x) = \sqrt{\lim_{r \rightarrow x} \left\{ \frac{2r^2 [(f(r))^2 - f(x)f(r)]}{r^2 - x^2} - r^3 e^{\frac{f(r)}{r}} \right\}}$

be differentiable in $(-\infty, 0) \cup (0, \infty)$ and $f(1) = 1$.

Then the value of ea, such that $f(a) = 0$, is equal to _____.

Ans. 2

Sol. $f(1)=1, f(a) = 0$

$$f^2(x) = \lim_{r \rightarrow x} \left(\frac{2r^2 (f^2(r) - f(x)f(r))}{r^2 - x^2} - r^3 e^{\frac{f(r)}{r}} \right)$$

$$= \lim_{r \rightarrow x} \left(\frac{2r^2 f(r) (f(r) - f(x))}{r + x} \cdot \frac{1}{r - x} - r^3 e^{\frac{f(r)}{r}} \right)$$

$$f^2(x) = \frac{2x^2 f(x)}{2x} f'(x) - x^3 e^{\frac{f(x)}{x}}$$

$$y^2 = xy \frac{dy}{dx} - x^3 e^{\frac{y}{x}}$$

$$\frac{y}{x} = \frac{dy}{dx} - \frac{x^2}{y} e^{\frac{y}{x}}$$

Put $y = vx \Rightarrow \frac{dy}{dx} = v + x \frac{dv}{dx}$

$$v = v + x \frac{dv}{dx} - \frac{x}{v} e^v$$

$$\frac{dv}{dx} = \frac{e^v}{v} \Rightarrow e^{-v} v dv = dx$$

Integrating both side

$$e^v (x + c) + 1 + v = 0$$

$$f(1) = 1 \Rightarrow x = 1, y = 1$$

$$\Rightarrow c = -1 - \frac{2}{e}$$

$$e^v \left(-1 - \frac{2}{e} + x \right) + 1 + v = 0$$

$$e^{\frac{y}{x}} \left(-1 - \frac{2}{e} + x \right) + 1 + \frac{y}{x} = 0$$

$$x = a, y = 0 \Rightarrow a = \frac{2}{e}$$

$$ae = 2$$

28. Remainder when $64^{32^{32}}$ is divided by 9 is equal to _____.

Ans. 1

Sol. Let $32^{32} = t$

$$64^{32^{32}} = 64^t = 8^{2t} = (9 - 1)^{2t}$$

$$= 9k + 1$$

Hence remainder = 1

29. Let the set $C = \{(x, y) | x^2 - 2^y = 2023, x, y \in \mathbb{N}\}$.

Then $\sum_{(x,y) \in C} (x + y)$ is equal to _____.

Ans. 46

Sol. $x^2 - 2^y = 2023$

$$\Rightarrow \boxed{x = 45, y = 1}$$

$$\sum_{(x,y) \in C} (x + y) = 46.$$

30. Let the slope of the line $45x + 5y + 3 = 0$ be

$$27r_1 + \frac{9r_2}{2} \quad \text{for some } r_1, r_2 \in \mathbb{R}. \quad \text{Then}$$

$$\lim_{x \rightarrow 3} \left(\int_3^x \frac{8t^2}{\frac{3r_2 x}{2} - r_2 x^2 - r_1 x^3 - 3x} dt \right) \text{ is equal to } \underline{\hspace{2cm}}.$$

Ans. 12

Sol. According to the question ,

$$27r_1 + \frac{9r_2}{2} = -9$$

$$\lim_{x \rightarrow 3} \frac{\int_3^x 8t^2 dt}{\frac{3r_2 x}{2} - r_2 x^2 - r_1 x^3 - 3x}$$

$$= \lim_{x \rightarrow 3} \frac{8x^2}{\frac{3r_2}{2} - 2r_2 x - 3r_1 x^2 - 3} \quad (\text{using LH' Rule})$$

$$= \frac{72}{\frac{3r_2}{2} - 6r_2 - 27r_1 - 3}$$

$$= \frac{72}{-\frac{9r_2}{2} - 27r_1 - 3}$$

$$= \frac{72}{9-3} = 12$$

AYJR
ARE YOU JEE READY?

PHYSICS

TEST PAPER WITH SOLUTION

SECTION-A

31. Two sources of light emit with a power of 200 W. The ratio of number of photons of visible light emitted by each source having wavelengths 300 nm and 500 nm respectively, will be :

- (1) 1 : 5 (2) 1 : 3
(3) 5 : 3 (4) 3 : 5

Ans. (4)

Sol. $n_1 \times \frac{hc}{\lambda_1} = 200$

$n_2 \times \frac{hc}{\lambda_2} = 200$

$\frac{n_1}{n_2} = \frac{\lambda_1}{\lambda_2} = \frac{300}{500}$

$\frac{n_1}{n_2} = \frac{3}{5}$

32. The truth table for this given circuit is :

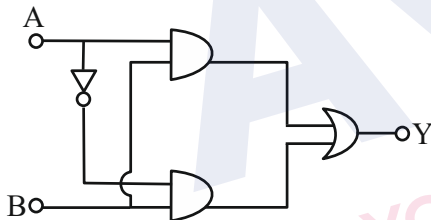

(1)

A	B	Y
0	0	1
0	1	1
1	0	1
1	1	0

(2)

A	B	Y
0	0	0
0	1	1
1	0	0
1	1	1

(3)

A	B	Y
0	0	0
0	1	0
1	0	0
1	1	1

(4)

A	B	Y
0	0	1
0	1	0
1	0	1
1	1	0

Ans. (2)

Sol.

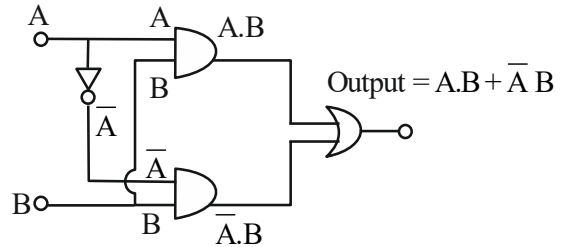

$Y = A.B + \bar{A}.B$
 $= (A + \bar{A}).B$

$Y = 1.B$

$Y = B$

33. A physical quantity Q is found to depend on quantities a, b, c by the relation $Q = \frac{a^4 b^3}{c^2}$. The percentage error in a, b and c are 3%, 4% and 5% respectively. Then, the percentage error in Q is :

- (1) 66% (2) 43%
(3) 34% (4) 14%

Ans. (3)

Sol. $Q = \frac{a^4 b^3}{c^2}$

$\frac{\Delta Q}{Q} = 4 \frac{\Delta a}{a} + 3 \frac{\Delta b}{b} + 2 \frac{\Delta c}{c}$

$\frac{\Delta Q}{Q} \times 100 = 4 \left(\frac{\Delta a}{a} \times 100 \right) + 3 \left(\frac{\Delta b}{b} \times 100 \right) + 2 \left(\frac{\Delta c}{c} \times 100 \right)$

% error in Q = $4 \times 3\% + 3 \times 4\% + 2 \times 5\%$
 $= 12\% + 12\% + 10\%$
 $= 34\%$

34. In an a.c. circuit, voltage and current are given by :
 $V = 100 \sin (100 t)$ V and

$I = 100 \sin (100 t + \frac{\pi}{3})$ mA respectively.

The average power dissipated in one cycle is :

- (1) 5 W (2) 10 W
(3) 2.5 W (4) 25 W

Ans. (3)

Sol. $P_{avg} = V_{rms} I_{rms} \cos(\Delta\phi)$

$$= \frac{100}{\sqrt{2}} \times \frac{100 \times 10^{-3}}{\sqrt{2}} \times \cos\left(\frac{\pi}{3}\right)$$

$$= \frac{10^4}{2} \times \frac{1}{2} \times 10^{-3}$$

$$= \frac{10}{4} = 2.5 \text{ W}$$

35. The temperature of a gas having 2.0×10^{25} molecules per cubic meter at 1.38 atm (Given, $k = 1.38 \times 10^{-23} \text{ JK}^{-1}$) is :

- (1) 500 K (2) 200 K
(3) 100 K (4) 300 K

Ans. (1)

Sol. $PV = nRT$

$$PV = \frac{N}{N_A} RT$$

$N =$ Total no. of molecules

$$P = \frac{N}{V} kT$$

$$1.38 \times 1.01 \times 10^5 = 2 \times 10^{25} \times 1.38 \times 10^{-23} \times T$$

$$1.01 \times 10^5 = 2 \times 10^2 \times T$$

$$T = \frac{1.01 \times 10^3}{2} \approx 500 \text{ K}$$

36. A stone of mass 900g is tied to a string and moved in a vertical circle of radius 1m making 10 rpm. The tension in the string, when the stone is at the lowest point is (if $\pi^2 = 9.8$ and $g = 9.8 \text{ m/s}^2$)

- (1) 97 N (2) 9.8 N
(3) 8.82 N (4) 17.8 N

Ans. (2)

Sol. Given that

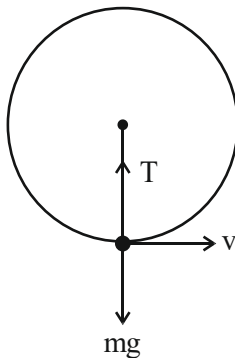

$$m = 900 \text{ gm} = \frac{900}{1000} \text{ kg} = \frac{9}{10} \text{ kg}$$

$$r = 1 \text{ m}$$

$$\omega = \frac{2\pi N}{60} = \frac{2\pi(10)}{60} = \frac{\pi}{3} \text{ rad/sec}$$

$$T - mg = m r \omega^2$$

$$T = mg + m r \omega^2$$

$$= \frac{9}{10} \times 9.8 + \frac{9}{10} \times 1 \left(\frac{\pi}{3}\right)^2$$

$$= 8.82 + \frac{9}{10} \times \frac{\pi^2}{9}$$

$$= 8.82 + 0.98$$

$$= 9.80 \text{ N}$$

37. The bob of a pendulum was released from a horizontal position. The length of the pendulum is 10m. If it dissipates 10% of its initial energy against air resistance, the speed with which the bob arrives at the lowest point is : [Use, $g : 10 \text{ ms}^{-2}$]

- (1) $6\sqrt{5} \text{ ms}^{-1}$ (2) $5\sqrt{6} \text{ ms}^{-1}$
(3) $5\sqrt{5} \text{ ms}^{-1}$ (4) $2\sqrt{5} \text{ ms}^{-1}$

Ans. (1)

Sol. $\ell = 10 \text{ m}$,

$$\text{Initial energy} = mg\ell$$

$$\text{So, } \frac{9}{10} mg\ell = \frac{1}{2} mv^2$$

$$\Rightarrow \frac{9}{10} \times 10 \times 10 = \frac{1}{2} v^2$$

$$v^2 = 180$$

$$v = \sqrt{180} = 6\sqrt{5} \text{ m/s}$$

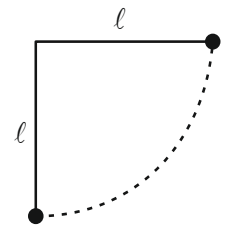

38. If the distance between object and its two times magnified virtual image produced by a curved mirror is 15 cm, the focal length of the mirror must be :

- (1) 15 cm (2) -12 cm
(3) -10 cm (4) 10/3 cm

Ans. (3)

Sol.

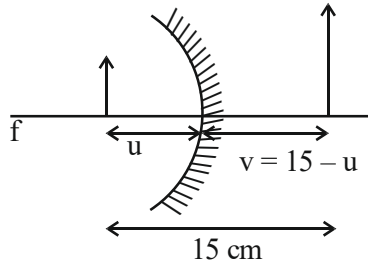

$$m = 2 = \frac{-v}{u}$$

$$2 = \frac{-(15 - u)}{-u}$$

$$2u = 15 - u$$

$$3u = 15 \Rightarrow u = 5 \text{ cm}$$

$$v = 15 - u = 15 - 5 = 10 \text{ cm}$$

$$\frac{1}{f} = \frac{1}{v} + \frac{1}{u}$$

$$= \frac{1}{10} + \frac{1}{(-5)} = \frac{1-2}{10} = \frac{-1}{10}$$

$$f = -10 \text{ cm}$$

39. Two particles X and Y having equal charges are being accelerated through the same potential difference. Thereafter they enter normally in a region of uniform magnetic field and describes circular paths of radii R_1 and R_2 respectively. The mass ratio of X and Y is :

(1) $\left(\frac{R_2}{R_1}\right)^2$ (2) $\left(\frac{R_1}{R_2}\right)^2$

(3) $\left(\frac{R_1}{R_2}\right)$ (4) $\left(\frac{R_2}{R_1}\right)$

Ans. (2)

Sol. $R = \frac{mv}{qB} = \frac{p}{qB} = \frac{\sqrt{2m(\text{KE})}}{qB} = \frac{\sqrt{2mqV}}{qB}$

$$R \propto \sqrt{m}$$

$$m \propto R^2$$

$$\frac{m_1}{m_2} = \left(\frac{R_1}{R_2}\right)^2$$

40. In Young's double slit experiment, light from two identical sources are superimposing on a screen. The path difference between the two lights reaching at a point on the screen is $\frac{7\lambda}{4}$. The ratio

of intensity of fringe at this point with respect to the maximum intensity of the fringe is :

- (1) $1/2$ (2) $3/4$ (3) $1/3$ (4) $1/4$

Ans. (1)

Sol. $\Delta x = \frac{7\lambda}{4}$

$$\phi = \frac{2\pi}{\lambda} \Delta x = \frac{2\pi}{\lambda} \times \frac{7\lambda}{4} = \frac{7\pi}{2}$$

$$I = I_{\max} \cos^2\left(\frac{\phi}{2}\right)$$

$$\frac{I}{I_{\max}} = \cos^2\left(\frac{\phi}{2}\right) = \cos^2\left(\frac{7\pi}{2 \times 2}\right) = \cos^2\left(\frac{7\pi}{4}\right)$$

$$= \cos^2\left(2\pi - \frac{\pi}{4}\right)$$

$$= \cos^2 \frac{\pi}{4}$$

$$= \frac{1}{2}$$

41. A small liquid drop of radius R is divided into 27 identical liquid drops. If the surface tension is T , then the work done in the process will be :

(1) $8\pi R^2 T$ (2) $3\pi R^2 T$

(3) $\frac{1}{8} \pi R^2 T$ (4) $4\pi R^2 T$

Ans. (1)

Sol. Volume constant

$$\frac{4}{3} \pi R^3 = 27 \times \frac{4}{3} \times \pi r^3$$

$$R^3 = 27r^3$$

$$R = 3r$$

$$r = \frac{R}{3}$$

$$r^2 = \frac{R^2}{9}$$

$$\text{Work done} = T \cdot \Delta A$$

$$= 27 T(4\pi r^2) - T 4\pi R^2$$

$$= 27T4\pi \frac{R^2}{9} - 4\pi R^2 T$$

$$= 8\pi R^2 T$$

42. A bob of mass 'm' is suspended by a light string of length 'L'. It is imparted a minimum horizontal velocity at the lowest point A such that it just completes half circle reaching the top most position B. The ratio of kinetic energies $\frac{(K.E.)_A}{(K.E.)_B}$ is :

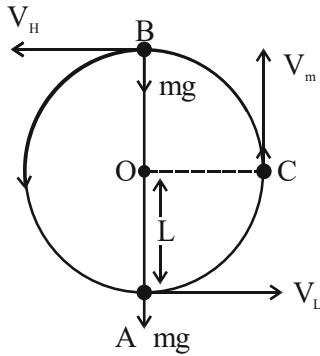

- (1) 3 : 2 (2) 5 : 1
(3) 2 : 5 (4) 1 : 5

Ans. (2)

Sol. Apply energy conservation between A & B

$$\frac{1}{2}mV_L^2 = \frac{1}{2}mV_H^2 + mg(2L)$$

$$\therefore V_L = \sqrt{5gL}$$

$$\text{So, } V_H = \sqrt{gL}$$

$$\frac{(K.E.)_A}{(K.E.)_B} = \frac{\frac{1}{2}m(\sqrt{5gL})^2}{\frac{1}{2}m(\sqrt{gL})^2} = \frac{5}{1}$$

43. A wire of length L and radius r is clamped at one end. If its other end is pulled by a force F, its length increases by l. If the radius of the wire and the applied force both are reduced to half of their original values keeping original length constant, the increase in length will become.

- (1) 3 times (2) 3/2 times
(3) 4 times (4) 2 times

Ans. (4)

Sol. $Y = \frac{\text{stress}}{\text{strain}}$

$$Y = \frac{F}{\frac{\pi r^2}{L}}$$

$$F = Y\pi r^2 \times \frac{\ell}{L} \quad \dots(i)$$

$$Y = \frac{F/2}{\frac{\Delta \ell}{L}}$$

$$F = Y \frac{\Delta \ell}{L} \times 2 \times \frac{\pi r^2}{4}$$

From (i)

$$Y\pi r^2 \frac{\ell}{L} = Y \frac{\Delta \ell}{L} \frac{\pi r^2}{2}$$

$$\Delta \ell = 2\ell$$

44. A planet takes 200 days to complete one revolution around the Sun. If the distance of the planet from Sun is reduced to one fourth of the original distance, how many days will it take to complete one revolution ?

- (1) 25 (2) 50
(3) 100 (4) 20

Ans. (1)

Sol. $T^2 \propto r^3$

$$\frac{T_1^2}{r_1^3} = \frac{T_2^2}{r_2^3}$$

$$\frac{(200)^2}{r^3} = \frac{T_2^2}{\left(\frac{r}{4}\right)^3}$$

$$\frac{200 \times 200}{4 \times 4 \times 4} = T_2^2$$

$$T_2 = \frac{200}{4 \times 2}$$

$$T_2 = 25 \text{ days}$$

45. A plane electromagnetic wave of frequency 35 MHz travels in free space along the X-direction. At a particular point (in space and time) $\vec{E} = 9.6\hat{j}\text{V/m}$. The value of magnetic field at this point is :

- (1) $3.2 \times 10^{-8}\hat{k}\text{T}$ (2) $3.2 \times 10^{-8}\hat{i}\text{T}$
(3) $9.6\hat{j}\text{T}$ (4) $9.6 \times 10^{-8}\hat{k}\text{T}$

Ans. (1)

Sol. $\frac{E}{B} = C$

$\frac{E}{B} = 3 \times 10^8$

$B = \frac{E}{3 \times 10^8} = \frac{9.6}{3 \times 10^8}$

$B = 3.2 \times 10^{-8}\text{T}$

$\vec{B} = \hat{v} \times \vec{E}$
 $= \hat{i} \times \hat{j} = \hat{k}$

So,

$\vec{B} = 3.2 \times 10^{-8}\hat{k}\text{T}$

46. In the given circuit, the current in resistance R_3 is :

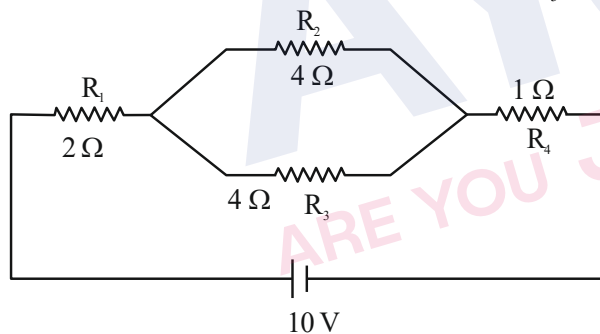

- (1) 1 A (2) 1.5 A
(3) 2 A (4) 2.5 A

Ans. (1)

Sol.

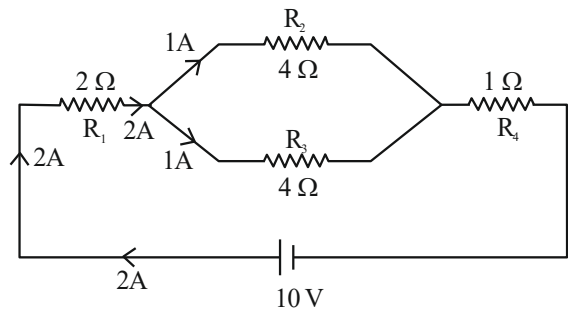

$R_{eq} = 2\Omega + 2\Omega + 1\Omega = 5\Omega$

$i = \frac{V}{R_{eq}} = \frac{10}{5} = 2\text{A}$

Current in resistance $R_3 = 2 \times \left(\frac{4}{4+4}\right)$
 $= 2 \times \frac{4}{8}$
 $= 1\text{A}$

47. A particle is moving in a straight line. The variation of position 'x' as a function of time 't' is given as $x = (t^3 - 6t^2 + 20t + 15)\text{m}$. The velocity of the body when its acceleration becomes zero is :

- (1) 4 m/s (2) 8 m/s
(3) 10 m/s (4) 6 m/s

Ans. (2)

Sol. $x = t^3 - 6t^2 + 20t + 15$

$\frac{dx}{dt} = v = 3t^2 - 12t + 20$

$\frac{dv}{dt} = a = 6t - 12$

When $a = 0$

$6t - 12 = 0; t = 2\text{ sec}$

At $t = 2\text{ sec}$

$v = 3(2)^2 - 12(2) + 20$

$v = 8\text{ m/s}$

48. N moles of a polyatomic gas ($f = 6$) must be mixed with two moles of a monoatomic gas so that the mixture behaves as a diatomic gas. The value of N is :

- (1) 6 (2) 3 (3) 4 (4) 2

Ans. (3)

Sol. $f_{eq} = \frac{n_1 f_1 + n_2 f_2}{n_1 + n_2}$

For diatomic gas $f_{eq} = 5$

$5 = \frac{(N)(6) + (2)(3)}{N + 2}$

$5N + 10 = 6N + 6$

$N = 4$

49. Given below are two statements :

Statement I : Most of the mass of the atom and all its positive charge are concentrated in a tiny nucleus and the electrons revolve around it, is Rutherford's model.

Statement II : An atom is a spherical cloud of positive charges with electrons embedded in it, is a special case of Rutherford's model.

In the light of the above statements, choose the most appropriate from the options given below.

- (1) Both statement I and statement II are false
- (2) Statement I is false but statement II is true
- (3) Statement I is true but statement II is false
- (4) Both statement I and statement II are true

Ans. (3)

Sol. According to Rutherford atomic model, most of mass of atom and all its positive charge is concentrated in tiny nucleus & electron revolve around it.

According to Thomson atomic model, atom is spherical cloud of positive charge with electron embedded in it.

Hence,

Statement I is true but statement II false.

50. An electric field is given by $(6\hat{i} + 5\hat{j} + 3\hat{k}) \text{ N/C}$.

The electric flux through a surface area $30\hat{i} \text{ m}^2$ lying in YZ-plane (in SI unit) is :

- (1) 90
- (2) 150
- (3) 180
- (4) 60

Ans. (3)

Sol. $\vec{E} = 6\hat{i} + 5\hat{j} + 3\hat{k}$

$$\vec{A} = 30\hat{i}$$

$$\phi = \vec{E} \cdot \vec{A}$$

$$\phi = (6\hat{i} + 5\hat{j} + 3\hat{k}) \cdot (30\hat{i})$$

$$\phi = 6 \times 30 = 180$$

SECTION-B

51. Two metallic wires P and Q have same volume and are made up of same material. If their area of cross sections are in the ratio 4 : 1 and force F_1 is applied to P, an extension of Δl is produced. The force which is required to produce same extension in Q is F_2 .

The value of $\frac{F_1}{F_2}$ is _____.

Ans. (16)

Sol.
$$Y = \frac{\text{Stress}}{\text{Strain}} = \frac{F/A}{\Delta l/l} = \frac{Fl}{A\Delta l}$$

$$\Delta l = \frac{Fl}{AY}$$

$$V = Al \Rightarrow l = \frac{V}{A}$$

$$\Delta l = \frac{FV}{A^2Y}$$

Y & V is same for both the wires

$$\Delta l \propto \frac{F}{A^2}$$

$$\frac{\Delta l_1}{\Delta l_2} = \frac{F_1}{A_1^2} \times \frac{A_2^2}{F_2}$$

$$\Delta l_1 = \Delta l_2$$

$$F_1 A_2^2 = F_2 A_1^2$$

$$\frac{F_1}{F_2} = \frac{A_1^2}{A_2^2} = \left(\frac{4}{1}\right)^2 = 16$$

52. A horizontal straight wire 5 m long extending from east to west falling freely at right angle to horizontal component of earth's magnetic field $0.60 \times 10^{-4} \text{ Wb/m}^2$. The instantaneous value of emf induced in the wire when its velocity is 10 ms^{-1} is _____ $\times 10^{-3} \text{ V}$.

Ans. (3)

Sol. $B_H = 0.60 \times 10^{-4} \text{ Wb/m}^2$

$$\text{Induced emf } e = B_H v l$$

$$= 0.60 \times 10^{-4} \times 10 \times 5$$

$$= 3 \times 10^{-3} \text{ V}$$

53. Hydrogen atom is bombarded with electrons accelerated through a potential different of V, which causes excitation of hydrogen atoms. If the experiment is being formed at $T = 0 \text{ K}$. The minimum potential difference needed to observe any Balmer series lines in the emission spectra will be $\frac{\alpha}{10} \text{ V}$, where $\alpha =$ _____.

Ans. (121)

Sol. For minimum potential difference electron has to make transition from $n = 3$ to $n = 2$ state but first electron has to reach to $n = 3$ state from ground state. So, energy of bombarding electron should be equal to energy difference of $n = 3$ and $n = 1$ state.

$$\Delta E = 13.6 \left[1 - \frac{1}{3^2} \right] e = eV$$

$$\frac{13.6 \times 8}{9} = V$$

$$V = 12.09 \text{ V} \approx 12.1 \text{ V}$$

$$\text{So, } \alpha = 121$$

54. A charge of $4.0 \mu\text{C}$ is moving with a velocity of $4.0 \times 10^6 \text{ ms}^{-1}$ along the positive y -axis under a magnetic field \vec{B} of strength $(2\hat{k})$ T. The force acting on the charge is $x\hat{i}$ N. The value of x is ___.

Ans. (32)

Sol. $q = 4 \mu\text{C}$, $\vec{v} = 4 \times 10^6 \hat{j} \text{ m/s}$

$$\vec{B} = 2\hat{k}\text{T}$$

$$\vec{F} = q(\vec{v} \times \vec{B})$$

$$= 4 \times 10^{-6} (4 \times 10^6 \hat{j} \times 2\hat{k})$$

$$= 4 \times 10^{-6} \times 8 \times 10^6 \hat{i}$$

$$\vec{F} = 32\hat{i} \text{ N}$$

$$x = 32$$

55. A simple harmonic oscillator has an amplitude A and time period 6π second. Assuming the oscillation starts from its mean position, the time required by it to travel from $x = A$ to $x = \frac{\sqrt{3}}{2}A$

will be $\frac{\pi}{x}$ s, where $x =$ _____ :

Ans. (2)

Sol.

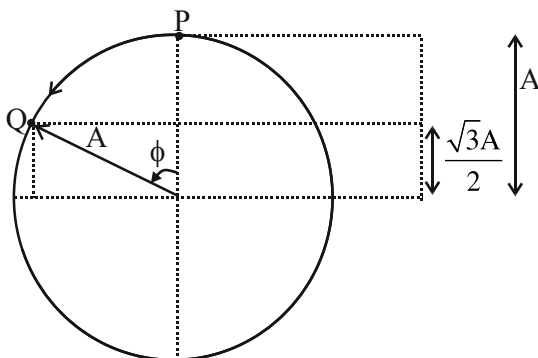

From phasor diagram particle has to move from P to Q in a circle of radius equal to amplitude of SHM.

$$\cos \phi = \frac{\frac{\sqrt{3}A}{2}}{A} = \frac{\sqrt{3}}{2}$$

$$\phi = \frac{\pi}{6}$$

$$\text{Now, } \frac{\pi}{6} = \omega t$$

$$\frac{\pi}{6} = \frac{2\pi}{T} t$$

$$\frac{\pi}{6} = \frac{2\pi}{6\pi} t$$

$$t = \frac{\pi}{2}$$

$$\text{So, } x = 2$$

56. In the given figure, the charge stored in $6\mu\text{F}$ capacitor, when points A and B are joined by a connecting wire is _____ μC .

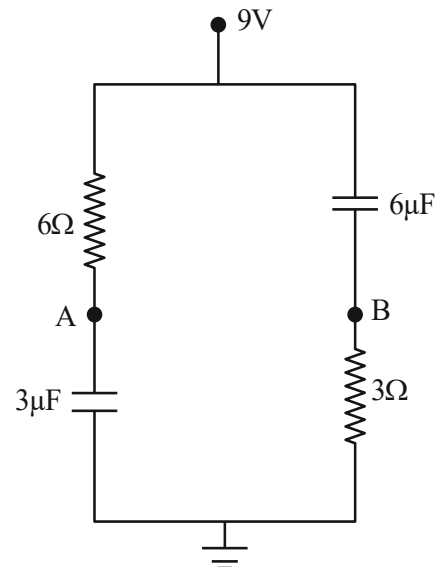

Ans. (36)

Sol. At steady state, capacitor behaves as an open circuit and current flows in circuit as shown in the diagram.

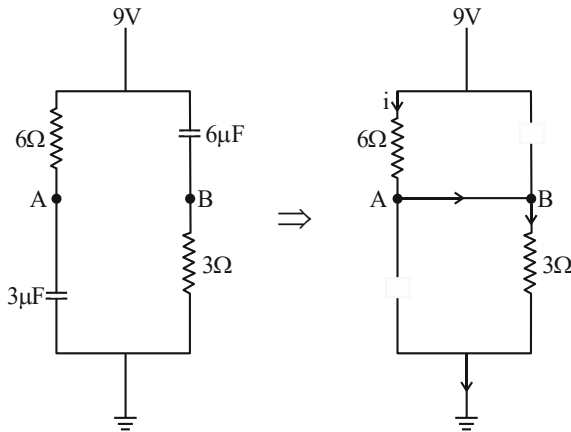

$$R_{eq} = 9 \Omega$$

$$i = \frac{9 \text{ V}}{9 \Omega} = 1 \text{ A}$$

$$\Delta V_{6\Omega} = 1 \times 6 = 6 \text{ V}$$

$$V_A = 3 \text{ V}$$

So, potential difference across $6\mu\text{F}$ is 6 V.

$$\begin{aligned} \text{Hence } Q &= C\Delta V \\ &= 6 \times 6 \times 10^{-6} \text{ C} \\ &= 36 \mu\text{C} \end{aligned}$$

57. In a single slit diffraction pattern, a light of wavelength 6000 \AA is used. The distance between the first and third minima in the diffraction pattern is found to be 3 mm when the screen is placed 50 cm away from slits. The width of the slit is $\times 10^{-4} \text{ m}$.

Ans. (2)

Sol. For n^{th} minima

$$b \sin \theta = n\lambda$$

(λ is small so $\sin \theta$ is small, hence $\sin \theta \approx \tan \theta$)

$$b \tan \theta = n\lambda$$

$$b \frac{y}{D} = n\lambda$$

$$\Rightarrow y_n = \frac{n\lambda D}{b} \text{ (Position of } n^{\text{th}} \text{ minima)}$$

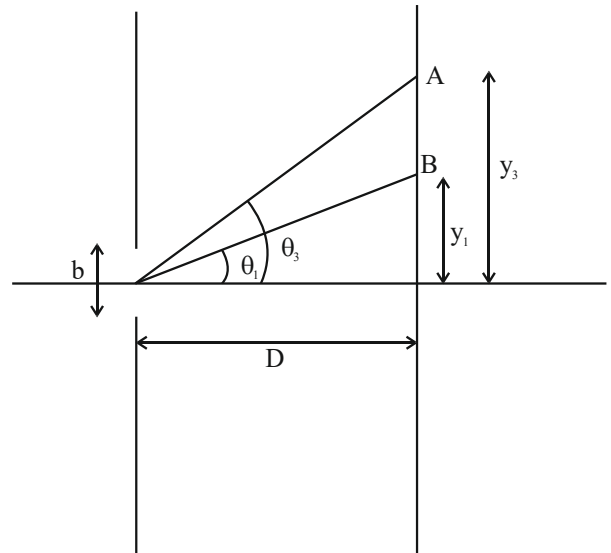

$B \rightarrow 1^{\text{st}}$ minima, $A \rightarrow 3^{\text{rd}}$ minima

$$y_3 = \frac{3\lambda D}{b}, \quad y_1 = \frac{\lambda D}{b}$$

$$\Delta y = y_3 - y_1 = \frac{2\lambda D}{b}$$

$$3 \times 10^{-3} = \frac{2 \times 6000 \times 10^{-10} \times 0.5}{b}$$

$$b = \frac{2 \times 6000 \times 10^{-10} \times 0.5}{3 \times 10^{-3}}$$

$$b = 2 \times 10^{-4} \text{ m}$$

$$x = 2$$

58. In the given circuit, the current flowing through the resistance 20Ω is 0.3 A, while the ammeter reads 0.9 A. The value of R_1 is Ω .

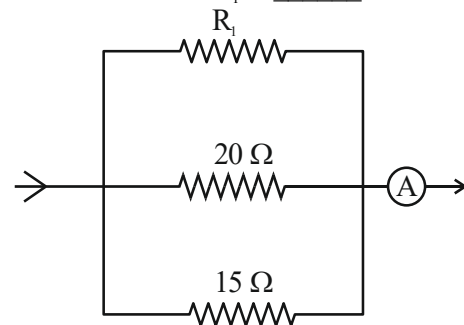

Ans. (30)

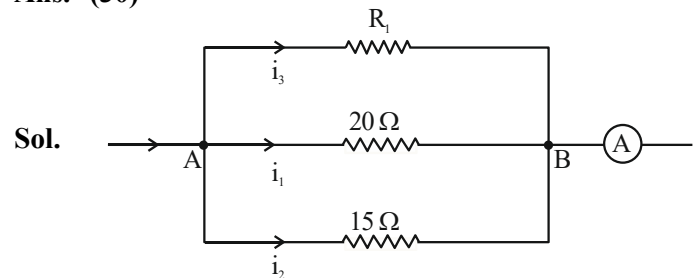

Sol.

$$\text{Given, } i_1 = 0.3 \text{ A, } i_1 + i_2 + i_3 = 0.9 \text{ A}$$

$$\text{So, } V_{AB} = i_1 \times 20\Omega = 20 \times 0.3 \text{ V} = 6 \text{ V}$$

$$i_2 = \frac{6V}{15\Omega} = \frac{2}{5} \text{ A}$$

$$i_1 + i_2 + i_3 = \frac{9}{10} \text{ A}$$

$$\frac{3}{10} + \frac{2}{5} + i_3 = \frac{9}{10}$$

$$\frac{7}{10} + i_3 = \frac{9}{10}$$

$$i_3 = 0.2 \text{ A}$$

$$\text{So, } i_3 \times R_1 = 6 \text{ V}$$

$$(0.2)R_1 = 6$$

$$R_1 = \frac{6}{0.2} = 30 \Omega$$

59. A particle is moving in a circle of radius 50 cm in such a way that at any instant the normal and tangential components of its acceleration are equal. If its speed at $t = 0$ is 4 m/s, the time taken to complete the first revolution will be $\frac{1}{\alpha} [1 - e^{-2\pi}]$ s,

where $\alpha = \underline{\hspace{2cm}}$.

Ans. (8)

Sol. $|\vec{a}_c| = |\vec{a}_t|$

$$\frac{v^2}{r} = \frac{dv}{dt}$$

$$\Rightarrow \int_4^v \frac{dv}{v^2} = \int_0^t \frac{dt}{r}$$

$$\Rightarrow \left[\frac{-1}{v} \right]_4^v = \frac{t}{r}$$

$$\Rightarrow \frac{-1}{v} + \frac{1}{4} = \frac{t}{r}$$

$$\Rightarrow v = \frac{4}{1-8t} = \frac{ds}{dt}$$

$$4 \int_0^t \frac{dt}{1-8t} = \int_0^s ds$$

$$(r = 0.5 \text{ m})$$

$$s = 2\pi r = \pi$$

$$4 \times \frac{[\ln(1-8t)]_0^t}{-8} = \pi$$

$$\ln(1-8t) = -2\pi$$

$$1-8t = e^{-2\pi}$$

$$t = (1 - e^{-2\pi}) \frac{1}{8} \text{ s}$$

$$\text{So, } \alpha = 8$$

60. A body of mass 5 kg moving with a uniform speed $3\sqrt{2} \text{ ms}^{-1}$ in X - Y plane along the line $y = x + 4$. The angular momentum of the particle about the origin will be $\underline{\hspace{2cm}} \text{ kg m}^2\text{s}^{-1}$.

Ans. (60)

Sol. $y - x - 4 = 0$

d_1 is perpendicular distance of given line from origin.

$$d_1 = \left| \frac{-4}{\sqrt{1^2 + 1^2}} \right| \Rightarrow 2\sqrt{2} \text{ m}$$

$$\text{So, } |\vec{L}| = mvd_1 = 5 \times 3\sqrt{2} \times 2\sqrt{2} \text{ kg m}^2/\text{s} \\ = 60 \text{ kg m}^2/\text{s}$$

CHEMISTRY

SECTION-A

61. The ascending acidity order of the following H atoms is

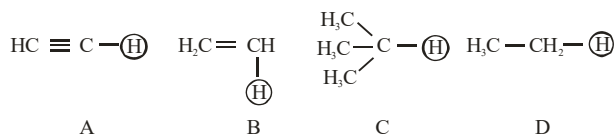

- (1) $\text{C} < \text{D} < \text{B} < \text{A}$
 (2) $\text{A} < \text{B} < \text{C} < \text{D}$
 (3) $\text{A} < \text{B} < \text{D} < \text{C}$
 (4) $\text{D} < \text{C} < \text{B} < \text{A}$

Ans. (1)

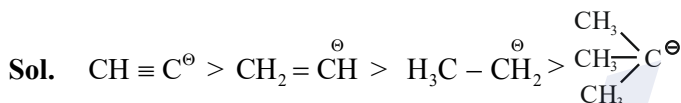

Stability of conjugate base \propto acidic strength

$\text{C} < \text{D} < \text{B} < \text{A}$

62. Match List I with List II

List I (Bio Polymer)		List II (Monomer)	
A.	Starch	I.	nucleotide
B.	Cellulose	II.	α -glucose
C.	Nucleic acid	III.	β -glucose
D.	Protein	IV.	α -amino acid

Choose the correct answer from the options given below :-

- (1) A-II, B-I, C-III, D-IV
 (2) A-IV, B-II, C-I, D-III
 (3) A-I, B-III, C-IV, D-II
 (4) A-II, B-III, C-I, D-IV

Ans. (4)

Sol. A-II, B-III, C-I, D-IV

Fact based.

TEST PAPER WITH SOLUTION

63. Match List I with List II

List I (Compound)		List II (pK _a value)	
A.	Ethanol	I.	10.0
B.	Phenol	II.	15.9
C.	m-Nitrophenol	III.	7.1
D.	p-Nitrophenol	IV.	8.3

Choose the correct answer from the options given below :-

- (1) A-I, B-II, C-III, D-IV
 (2) A-IV, B-I, C-II, D-III
 (3) A-III, B-IV, C-I, D-II
 (4) A-II, B-I, C-IV, D-III

Ans. (4)

Sol. Ethanol \rightarrow 15.9

Phenol \rightarrow 10

M-Nitrophenol \rightarrow 8.3

P-Nitrophenol \rightarrow 7.1

64. Which of the following reaction is correct ?

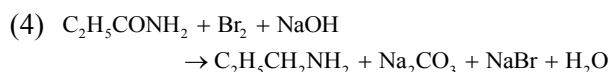
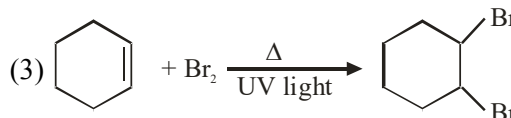
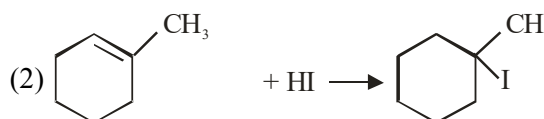
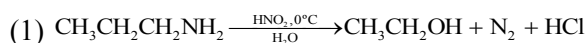

Ans. (2)

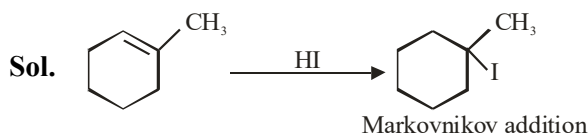

65. According to IUPAC system, the compound

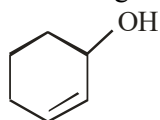

is named as

- (1) Cyclohex-1-en-2-ol (2) 1-Hydroxyhex-2-ene
 (3) Cyclohex-1-en-3-ol (4) Cyclohex-2-en-1-ol

Ans. (4)

Cyclohex-2-en-1-ol

66. The correct IUPAC name of K_2MnO_4 is

- (1) Potassium tetraoxopermanganate (VI)
 (2) Potassium tetraoxidomanganate (VI)
 (3) Dipotassium tetraoxidomanganate (VII)
 (4) Potassium tetraoxidomanganese (VI)

Ans. (2)

Sol. K_2MnO_4

$$2 + x - 8 = 0$$

$$\Rightarrow x = +6$$

O.S. of Mn = +6

IUPAC Name =

Potassium tetraoxidomanganate(VI)

67. A reagent which gives brilliant red precipitate with Nickel ions in basic medium is

- (1) sodium nitroprusside
 (2) neutral $FeCl_3$
 (3) meta-dinitrobenzene
 (4) dimethyl glyoxime

Ans. (4)

Sol. $Ni^{2+} + 2dmg^- \rightarrow [Ni(dmg)_2]$

Rosy red/Bright Red precipitate

68. Phenol treated with chloroform in presence of sodium hydroxide, which further hydrolysed in presence of an acid results

- (1) Salicylic acid
 (2) Benzene-1,2-diol
 (3) Benzene-1, 3-diol
 (4) 2-Hydroxybenzaldehyde

Ans. (4)

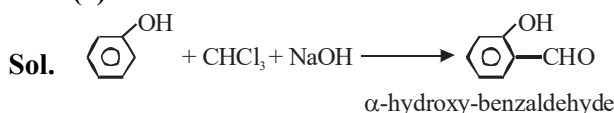

It is Reimer Tiemann Reaction

69. Match List I with List II

List I (Spectral Series for Hydrogen)		List II (Spectral Region/Higher Energy State)	
A.	Lyman	I.	Infrared region
B.	Balmer	II.	UV region
C.	Paschen	III.	Infrared region
D.	Pfund	IV.	Visible region

Choose the correct answer from the options given below :-

- (1) A-II, B-III, C-I, D-IV
 (2) A-I, B-III, C-II, D-IV
 (3) A-II, B-IV, C-III, D-I
 (4) A-I, B-II, C-III, D-IV

Ans. (3)

Sol. A - II, B - IV, C - III, D - I

Fact based.

70. On passing a gas, 'X', through Nessler's reagent, a brown precipitate is obtained. The gas 'X' is

- (1) H_2S (2) CO_2
 (3) NH_3 (4) Cl_2

Ans. (3)

Sol. Nessler's Reagent Reaction :

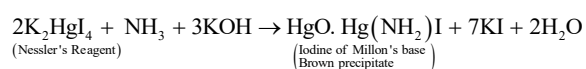

71. The product A formed in the following reaction is:

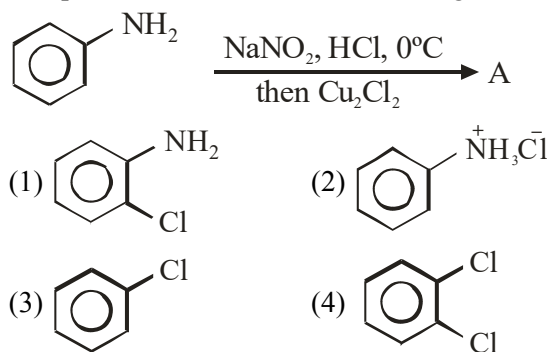

Ans. (3)

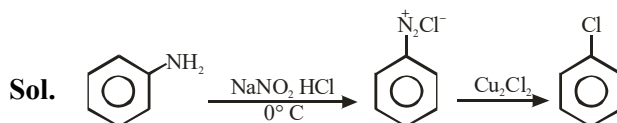

72. Identify the reagents used for the following conversion

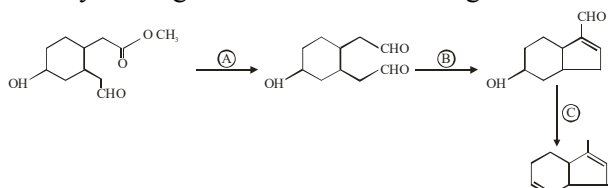

- (1) A = LiAlH_4 , B = $\text{NaOH}_{(\text{aq})}$, C = $\text{NH}_2\text{-NH}_2/\text{KOH}$, ethylene glycol
 (2) A = LiAlH_4 , B = $\text{NaOH}_{(\text{alc})}$, C = Zn/HCl
 (3) A = DIBAL-H, B = $\text{NaOH}_{(\text{aq})}$, C = $\text{NH}_2\text{-NH}_2/\text{KOH}$, ethylene glycol
 (4) A = DIBAL-H, B = $\text{NaOH}_{(\text{alc})}$, C = Zn/HCl

Ans. (4)

Sol.

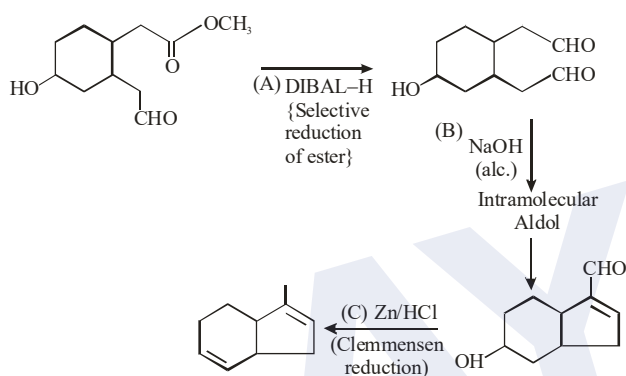

73. Which of the following acts as a strong reducing agent? (Atomic number : Ce = 58, Eu = 63, Gd = 64, Lu = 71)

- (1) Lu^{3+} (2) Gd^{3+}
 (3) Eu^{2+} (4) Ce^{4+}

Ans. (3)

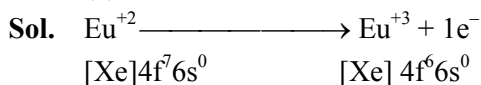

74. Chromatographic technique/s based on the principle of differential adsorption is/are

- A. Column chromatography
 B. Thin layer chromatography
 C. Paper chromatography

Choose the most appropriate answer from the options given below:

- (1) B only (2) A only
 (3) A & B only (4) C only

Ans. (3)

Sol. Memory Based

75. Which of the following statements are correct about Zn, Cd and Hg?

- A. They exhibit high enthalpy of atomization as the d-subshell is full.
 B. Zn and Cd do not show variable oxidation state while Hg shows +I and +II.
 C. Compounds of Zn, Cd and Hg are paramagnetic in nature.
 D. Zn, Cd and Hg are called soft metals.
 Choose the **most appropriate** from the options given below:

- (1) B, D only (2) B, C only
 (3) A, D only (4) C, D only

Sol. Ans. (1)

(A) Zn, Cd, Hg exhibit lowest enthalpy of atomization in respective transition series.

(C) Compounds of Zn, Cd and Hg are diamagnetic in nature.

76. The element having the highest first ionization enthalpy is

- (1) Si (2) Al
 (3) N (4) C

Ans. (3)

Sol. $\text{Al} < \text{Si} < \text{C} < \text{N}$; IE_1 order.

77. Alkyl halide is converted into alkyl isocyanide by reaction with

- (1) NaCN (2) NH_4CN
 (3) KCN (4) AgCN

Ans. (4)

Sol. Covalent character of AgCN.

78. Which one of the following will show geometrical isomerism?

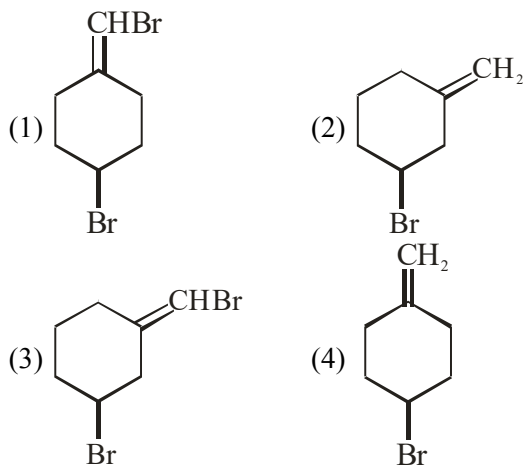

Ans. (3)

Sol. Due to unsymmetrical.

79. Given below are two statements:
Statement I: Fluorine has most negative electron gain enthalpy in its group.
Statement II: Oxygen has least negative electron gain enthalpy in its group.
 In the light of the above statements, choose the most appropriate from the options given below.
 (1) Both Statement I and Statement II are true
 (2) Statement I is true but Statement II is false
 (3) Both Statement I and Statement II are false
 (4) Statement I is false but Statement II is true

Ans. (4)
Sol. Statement-1 is false because chlorine has most negative electron gain enthalpy in its group.

80. Anomalous behaviour of oxygen is due to its
 (1) Large size and high electronegativity
 (2) Small size and low electronegativity
 (3) Small size and high electronegativity
 (4) Large size and low electronegativity

Ans. (3)
Sol. Fact Based.

SECTION-B

81. The total number of anti bonding molecular orbitals, formed from 2s and 2p atomic orbitals in a diatomic molecule is _____.

Ans. (4)
Sol. Antibonding molecular orbital from 2s = 1
 Antibonding molecular orbital from 2p = 3
 Total = 4

82. The oxidation number of iron in the compound formed during brown ring test for NO_3^- ion is _____.

Ans. (1)
Sol. $[\text{Fe}(\text{H}_2\text{O})_5(\text{NO})]^{2+}$,
 Oxidation no. of Fe = +1

83. The following concentrations were observed at 500 K for the formation of NH_3 from N_2 and H_2 . At equilibrium $[\text{N}_2] = 2 \times 10^{-2} \text{ M}$, $[\text{H}_2] = 3 \times 10^{-2} \text{ M}$ and $[\text{NH}_3] = 1.5 \times 10^{-2} \text{ M}$. Equilibrium constant for the reaction is _____.

Ans. (417)
Sol.
$$K_c = \frac{[\text{NH}_3]^2}{[\text{N}_2][\text{H}_2]^3}$$

$$K_c = \frac{(1.5 \times 10^{-2})^2}{(2 \times 10^{-2}) \times (3 \times 10^{-2})^3}$$

$$K_c = 417$$

84. Molality of 0.8 M H_2SO_4 solution (density 1.06 g cm^{-3}) is _____ $\times 10^{-3} \text{ m}$.

Ans. (815)

Sol.
$$m = \frac{M \times 1000}{d_{\text{sol}} \times 1000 - M \times \text{Molar mass}_{\text{solute}}}$$

$$815 \times 10^{-3} \text{ m}$$

85. If 50 mL of 0.5 M oxalic acid is required to neutralise 25 mL of NaOH solution, the amount of NaOH in 50 mL of given NaOH solution is _____ g.

Ans. (4)
Sol. Equivalent of Oxalic acid = Equivalents of NaOH
 $50 \times 0.5 \times 2 = 25 \times M \times 1$
 $M_{\text{NaOH}} = 2M$
 $W_{\text{NaOH}} \text{ in } 50\text{ml} = 2 \times 50 \times 40 \times 10^{-3} \text{ g} = 4\text{g}$

86. The total number of 'Sigma' and Pi bonds in 2-formylhex-4-enoic acid is _____.

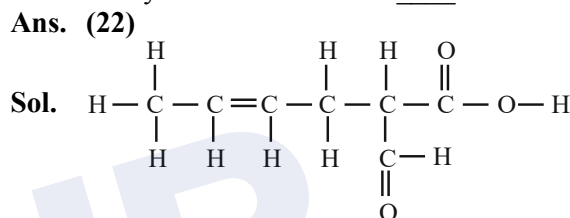

22 bonds

87. The half-life of radioisotopic bromine - 82 is 36 hours. The fraction which remains after one day is _____ $\times 10^{-2}$.
 (Given antilog 0.2006 = 1.587)

Ans. (63)
Sol. Half life of bromine - 82 = 36 hours

$$t_{1/2} = \frac{0.693}{K}$$

$$K = \frac{0.693}{36} = 0.01925 \text{ hr}^{-1}$$

1st order rxn kinetic equation

$$t = \frac{2.303}{K} \log \frac{a}{a-x}$$

$$\log \frac{a}{a-x} = \frac{t \times K}{2.303} \quad (t = 1 \text{ day} = 24\text{hr})$$

$$\log \frac{a}{a-x} = \frac{24\text{hr} \times 0.01925 \text{ hr}^{-1}}{2.303}$$

$$\log \frac{a}{a-x} = 0.2006$$

$$\frac{a}{a-x} = \text{anti log}(0.2006)$$

$$\frac{a}{a-x} = 1.587$$

$$\text{If } a = 1$$

$$\frac{1}{1-x} = 1.587 \Rightarrow 1 - x = 0.6301 = \text{Fraction remain after one day}$$

88. Standard enthalpy of vapourisation for CCl_4 is 30.5 kJ mol^{-1} . Heat required for vapourisation of 284g of CCl_4 at constant temperature is ____ kJ.
 (Given molar mass in g mol^{-1} ; C = 12, Cl = 35.5)

Ans. (56)

Sol. $\Delta H_{\text{vap}}^{\circ} \text{ CCl}_4 = 30.5 \text{ kJ / mol}$

Mass of $\text{CCl}_4 = 284 \text{ gm}$

Molar mass of $\text{CCl}_4 = 154 \text{ g/mol}$

Moles of $\text{CCl}_4 = \frac{284}{154} = 1.844 \text{ mol}$

$\Delta H_{\text{vap}}^{\circ}$ for 1 mole = 30.5 kJ/mol

$\Delta H_{\text{vap}}^{\circ}$ for 1.844 mol = 30.5×1.844
 = 56.242 kJ

89. A constant current was passed through a solution of AuCl_4^- ion between gold electrodes. After a period of 10.0 minutes, the increase in mass of cathode was 1.314 g. The total charge passed through the solution is _____ $\times 10^{-2} \text{ F}$.
 (Given atomic mass of Au = 197)

Ans. (2)

Sol. $\frac{W}{E} = \frac{\text{charge}}{1F}$

$$\frac{1.314}{197} = \frac{Q}{1F}$$

$$Q = 2 \times 10^{-2} \text{ F}$$

90. The total number of molecules with zero dipole moment among CH_4 , BF_3 , H_2O , HF , NH_3 , CO_2 and SO_2 is _____.

Ans. (3)

Sol. Molecules with zero dipole moment = CO_2 , CH_4 , BF_3

