

FINAL JEE–MAIN EXAMINATION – APRIL, 2023

(Held On Monday 10th April, 2023)

TIME : 3 : 00 PM to 6 : 00 PM

MATHEMATICS

TEST PAPER WITH SOLUTION

SECTION-A

Sol.

1. Let f be a continuous function satisfying
 $\int_0^t (f(x)+x^2) dx = \frac{4}{3}t^3, \forall t > 0$. Then $f\left(\frac{\pi^2}{4}\right)$ is
 equal to :

(1) $\pi\left(1 - \frac{\pi^3}{16}\right)$

(2) $-\pi^2\left(1 + \frac{\pi^2}{16}\right)$

(3) $-\pi\left(1 + \frac{\pi^3}{16}\right)$

(4) $\pi^2\left(1 - \frac{\pi^2}{16}\right)$

Official Ans. by NTA (1)

Sol. $\int_0^t (f(x)+x^2) dx = \frac{4}{3}t^3, \forall t > 0$

$(f(t^2)+t^4) = 2t$

$f(t^2) = 2t - t^4$

$t = \frac{\pi}{2} \Rightarrow f\left(\frac{\pi^2}{4}\right) = \frac{2\pi}{2} - \frac{\pi^4}{16}$

$= \pi - \frac{\pi^4}{16} = \pi\left(1 - \frac{\pi^3}{16}\right)$

2. Eight persons are to be transported from city A to city B in three cars of different makes. If each car can accommodate at most three persons, then the number of ways, in which they can be transported, is:

(1) 3360

(2) 1680

(3) 560

(4) 1120

Official Ans. by NTA (1)

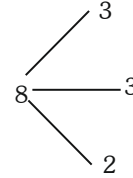

Ways = $\frac{8!}{3!3!2!} \times 3!$
 $= \frac{8 \times 7 \times 6 \times 5 \times 4}{4}$
 $= 56 \times 30$
 $= 1680$

3. For, $\alpha, \beta, \gamma, \delta \in \mathbb{N}$, if

$\int \left(\left(\frac{x}{e}\right)^{2x} + \left(\frac{e}{x}\right)^{2x} \right) \log_e x dx = \frac{1}{\alpha} \left(\frac{x}{e}\right)^{\beta x} - \frac{1}{\gamma} \left(\frac{e}{x}\right)^{\delta x} + C,$

Where $e = \sum_{n=0}^{\infty} \frac{1}{n!}$ and C is constant of integration,

then $\alpha + 2\beta + 3\gamma - 4\delta$ is equal to:

(1) 1

(2) -4

(3) -8

(4) 4

Official Ans. by NTA (4)

Sol. $(x = e^{\ln x})$

$\int \left(\left(\frac{x}{e}\right)^{2x} + \left(\frac{e}{x}\right)^{2x} \right) \log_e x dx = \int \left[e^{2(x \ln x - x)} + e^{-2(x \ln x - x)} \right] \ln x dx$

$x \ln x - x = t$

$\ln x \cdot dx = dt$

$\int (e^{2t} + e^{-2t}) dt$

$\frac{e^{2t}}{2} - \frac{e^{-2t}}{2} + C$

$= \frac{1}{2} \left(\frac{x}{e}\right)^{2x} - \frac{1}{2} \left(\frac{e}{x}\right)^{2x} + C$

$\alpha = \beta = \gamma = \delta = 2$

$\alpha + 2\beta + 3\gamma - 4\delta = 4$

4. Let the image of the point P(1, 2, 6) in the plane passing through the points A(1, 2, 0), B(1, 4, 1) and C(0, 5, 1) be Q(α, β, γ). Then (α² + β² + γ²) is equal to :

- (1) 65
- (2) 70
- (3) 76
- (4) 62

Official Ans. by NTA (1)

Sol. Equation of plane A(x - 1) + B(y - 2) + C(z - 0) = 0

Put (1, 4, 1) ⇒ 2B + C = 0

Put (0, 5, 1) ⇒ -A + 3B + C = 0

Sub : B - A = 0 ⇒ A = B, C = -2B

1(x - 1) + 1(y - 2) - 2(z - 0) = 0

x + y - 2z - 3 = 0

Image is (α, β, γ) pt ≡ (1, 2, 6)

$$\frac{\alpha - 1}{1} = \frac{\beta - 2}{1} = \frac{\gamma - 6}{-2} = \frac{-2(1 + 2 - 12 - 3)}{6}$$

$$\frac{\alpha - 1}{1} = \frac{\beta - 2}{1} = \frac{\gamma - 6}{-2} = 4$$

α = 5, β = 6, γ = -2 ⇒ α² + β² + γ² = 25 + 36 + 4 = 65

5. Let A = {2, 3, 4} and B = {8, 9, 12}. Then the number of elements in the relation

R = {(a₁, b₁), (a₂, b₂)} ∈ (A × B, A × B) : a₁ divides b₂ and a₂ divides b₁ is :

- (1) 36
- (2) 12
- (3) 18
- (4) 24

Official Ans. by NTA (1)

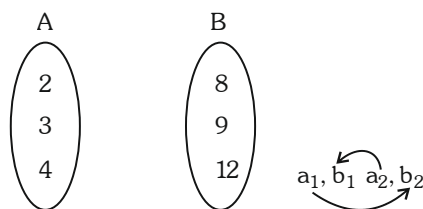

Sol.

a₁ divides b₂
 Each element has 2 choices
 ⇒ 3 × 2 = 6
 a₂ divides b₁
 Each element has 2 choices
 ⇒ 3 × 2 = 6
 Total = 6 × 6 = 36

6. If $A = \frac{1}{5!6!7!} \begin{bmatrix} 5! & 6! & 7! \\ 6! & 7! & 8! \\ 7! & 8! & 9! \end{bmatrix}$, then |adj(adj(2A))| is

equal to :

- (1) 2⁸
- (2) 2¹²
- (3) 2²⁰
- (4) 2¹⁶

Official Ans. by NTA (4)

Sol. |adjadj(2A)| = |2A|^{(n-1)²}

= |2A|⁴

= (2³ |A|)⁴

= 2¹² |A|⁴ ⇒ 2¹⁶

$$|A| = \frac{1}{5!6!7!} \begin{vmatrix} 1 & 6 & 42 \\ 1 & 7 & 56 \\ 1 & 8 & 72 \end{vmatrix}$$

R₃ → R₃ - R₂

R₂ → R₂ - R₁

$$|A| = \begin{vmatrix} 1 & 8 & 42 \\ 0 & 1 & 14 \\ 0 & 1 & 16 \end{vmatrix} = 2$$

7. Let A be the point (1, 2) and B be any point on the curve x² + y² = 16. If the centre of the locus of the point P, which divides the line segment AB in the ratio 3 : 2 is the point C(α, β), then the length of the line segment AC is

(1) $\frac{6\sqrt{5}}{5}$ (2) $\frac{4\sqrt{5}}{5}$

(3) $\frac{2\sqrt{5}}{5}$ (4) $\frac{3\sqrt{5}}{5}$

Official Ans. by NTA (4)

Sol. $A(1, 2) \quad P(h, k) \quad B(4\cos\theta, 4\sin\theta)$

$$\frac{12\cos\theta + 2}{5} = h \quad \Rightarrow \quad 12\cos\theta = 5h - 2$$

$$\frac{12\sin\theta + 4}{5} = k \quad \Rightarrow \quad 12\sin\theta = 5k - 4$$

Sq & add :

$$144 = (5h - 2)^2 + (5k - 4)^2$$

$$\left(x - \frac{2}{5}\right)^2 + \left(y - \frac{4}{5}\right)^2 = \frac{144}{25}$$

$$\text{Centre} \equiv \left(\frac{2}{5}, \frac{4}{5}\right) \equiv (\alpha, \beta)$$

$$AC = \sqrt{\left(1 - \frac{2}{5}\right)^2 + \left(2 - \frac{4}{5}\right)^2}$$

$$= \sqrt{\frac{9}{25} + \frac{36}{25}} = \frac{\sqrt{45}}{5} = \frac{3\sqrt{5}}{5}$$

8. Let a die be rolled n times. Let the probability of getting odd numbers seven times be equal to the probability of getting odd numbers nine times. If the probability of getting even numbers twice is $\frac{k}{2^{15}}$, then k is equal to :

- (1) 30
- (2) 90
- (3) 15
- (4) 60

Official Ans. by NTA (4)

Sol. $P(\text{odd number 7 times}) = P(\text{odd number 9 times})$

$${}^n C_7 \left(\frac{1}{2}\right)^7 \left(\frac{1}{2}\right)^{n-7} = {}^n C_9 \left(\frac{1}{2}\right)^9 \left(\frac{1}{2}\right)^{n-9}$$

$${}^n C_7 = {}^n C_9$$

$$\Rightarrow n = 16$$

Required

$$P = {}^{16} C_2 \times \left(\frac{1}{2}\right)^{16}$$

$$= \frac{16 \cdot 15}{2} \times \frac{1}{2^{16}} = \frac{15}{2^{13}}$$

$$\Rightarrow \frac{60}{2^{15}} \Rightarrow k = 60$$

9. Let $g(x) = f(x) + f(1-x)$ and $f''(x) > 0, x \in (0, 1)$. If g is decreasing in the interval $(0, \alpha)$ and increasing in the interval $(\alpha, 1)$, then $\tan^{-1}(2\alpha) + \tan^{-1}\left(\frac{1}{\alpha}\right) + \tan^{-1}\left(\frac{\alpha+1}{\alpha}\right)$ is equal to :

- (1) $\frac{3\pi}{2}$
- (2) π
- (3) $\frac{5\pi}{4}$
- (4) $\frac{3\pi}{4}$

Official Ans. by NTA (2)

Sol. $g(x) = f(x) + f(1-x)$ & $f''(x) > 0, x \in (0, 1)$

$$g'(x) = f'(x) - f'(1-x) = 0$$

$$\Rightarrow f'(x) = f'(1-x)$$

$$x = 1-x$$

$$x = \frac{1}{2}$$

$$g'(x) = 0$$

$$\text{at } x = \frac{1}{2}$$

$$g''(x) = f''(x) + f''(1-x) > 0$$

g is concave up

$$\text{hence } \alpha = \frac{1}{2}$$

$$\tan^{-1} 2\alpha + \tan^{-1} \frac{1}{\alpha} + \tan^{-1} \frac{\alpha+1}{\alpha}$$

$$\Rightarrow \tan^{-1} 1 + \tan^{-1} 2 + \tan^{-1} 3 = \pi$$

10. Let a circle of radius 4 be concentric to the ellipse $15x^2 + 19y^2 = 285$. Then the common tangents are inclined to the minor axis of the ellipse at the angle.

- (1) $\frac{\pi}{4}$ (2) $\frac{\pi}{3}$
- (3) $\frac{\pi}{12}$ (4) $\frac{\pi}{6}$

Official Ans. by NTA (2)

Sol. $\frac{x^2}{19} + \frac{y^2}{15} = 1$

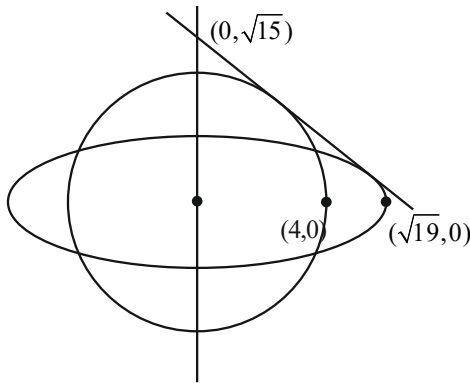

Let tang be

$$y = mx \pm \sqrt{19m^2 + 15}$$

$$mx - y \pm \sqrt{19m^2 + 15} = 0$$

Parallel from $(0, 0) = 4$

$$\left| \frac{\pm \sqrt{19m^2 + 15}}{\sqrt{m^2 + 1}} \right| = 4$$

$$19m^2 + 15 = 16m^2 + 16$$

$$3m^2 = 1$$

$$m = \pm \frac{1}{\sqrt{3}}$$

$$\theta = \frac{\pi}{6} \text{ with x-axis}$$

$$\text{Required angle } \frac{\pi}{3}$$

11. Let $\vec{a} = 2\hat{i} + 7\hat{j} - \hat{k}$, $\vec{b} = 3\hat{i} + 5\hat{k}$ and $\vec{c} = \hat{i} - \hat{j} + 2\hat{k}$

. Let \vec{d} be a vector which is perpendicular to both \vec{a} and \vec{b} , and $\vec{c} \cdot \vec{d} = 12$. Then

$$(-\hat{i} + \hat{j} - \hat{k}) \cdot (\vec{c} \times \vec{d}) \text{ is equal to}$$

(1) 48

(2) 42

(3) 44

(4) 24

Official Ans. by NTA (3)

Sol. $\vec{a} = 2\hat{i} + 7\hat{j} - \hat{k}$

$$\vec{b} = 3\hat{i} + 5\hat{k}$$

$$\vec{c} = \hat{i} - \hat{j} + 2\hat{k}$$

$$\vec{d} = \lambda(\vec{a} \times \vec{b}) = \lambda \begin{vmatrix} \hat{i} & \hat{j} & \hat{k} \\ 2 & 7 & -1 \\ 3 & 0 & 5 \end{vmatrix}$$

$$\vec{d} = \lambda(35\hat{i} - 13\hat{j} - 21\hat{k})$$

$$\lambda(35 + 13 - 42) = 12$$

$$\lambda = 2$$

$$\vec{d} = 2(35\hat{i} - 13\hat{j} - 21\hat{k})$$

$$(\hat{i} + \hat{j} - \hat{k})(\vec{c} \times \vec{d})$$

$$= \begin{vmatrix} -1 & 1 & -1 \\ 1 & -1 & 2 \\ 70 & -26 & -42 \end{vmatrix} = 44$$

12. If $S_n = 4 + 11 + 21 + 34 + 50 + \dots$ to n terms,

then $\frac{1}{60}(S_{29} - S_9)$ is equal to

(1) 226

(2) 220

(3) 223

(4) 227

Official Ans. by NTA (3)

Sol. $S_n = 4 + 11 + 21 + 34 + 50 + \dots + n$ terms
Difference are in A.P.

$$\text{Let } T_n = an^2 + bn + c$$

$$T_1 = a + b + c = 4$$

$$T_2 = 4a + 2b + c = 11$$

$$T_3 = 9a + 3b + c = 21$$

By solving these 3 equations

$$a = \frac{3}{2}, b = \frac{5}{2}, c = 0$$

$$\text{So } T_n = \frac{3}{2}n^2 + \frac{5}{2}n$$

$$S_n = \sum T_n$$

$$= \frac{3}{2} \sum n^2 + \frac{5}{2} \sum n$$

$$= \frac{3}{2} \frac{n(n+1)(2n+1)}{6} + \frac{5}{2} \frac{(n)(n+1)}{2}$$

$$= \frac{n(n+1)}{4} [2n+1+5]$$

$$S_n = \frac{n(n+1)}{4} (2n+6) = \frac{n(n+1)(n+3)}{2}$$

$$\frac{1}{60} \left(\frac{29 \times 30 \times 32}{2} - \frac{9 \times 10 \times 12}{2} \right) = 223$$

13. If the points P and Q are respectively the circumcentre and the orthocentre of a ΔABC , then

$\vec{PA} + \vec{PB} + \vec{PC}$ is equal to

- (1) $2\vec{QP}$ (2) \vec{QP}
 (3) $2\vec{PQ}$ (4) \vec{PQ}

Official Ans. by NTA (4)

Sol.

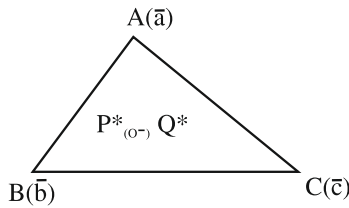

$$\vec{PA} + \vec{PB} + \vec{PC} = \vec{a} + \vec{b} + \vec{c}$$

$$\vec{PG} = \frac{\vec{a} + \vec{b} + \vec{c}}{3}$$

$$\Rightarrow \vec{a} + \vec{b} + \vec{c} = 3\vec{PG} = \vec{PQ}$$

Ans. (4)

14. The statement $\sim[p \vee (\sim(p \wedge q))]$ is equivalent to

- (1) $(\sim(p \wedge q)) \wedge q$
 (2) $\sim(p \wedge q)$
 (3) $\sim(p \vee q)$
 (4) $(p \wedge q) \wedge (\sim p)$

Official Ans. by NTA (4)

Sol. $\sim[p \vee (\sim(p \wedge q))]$

$$\sim p \wedge (p \wedge q)$$

15. Let $S = \left\{ x \in \left(-\frac{\pi}{2}, \frac{\pi}{2} \right) : 9^{1-\tan^2 x} + 9^{\tan^2 x} = 10 \right\}$ and

$$\beta = \sum_{x \in S} \tan^2 \left(\frac{x}{3} \right), \text{ then } \frac{1}{6}(\beta - 14)^2 \text{ is equal to}$$

- (1) 32
 (2) 8
 (3) 64
 (4) 16

Official Ans. by NTA (1)

Sol. Let $9^{\tan^2 x} = P$

$$\frac{9}{P} + P = 10$$

$$P^2 - 10P + 9 = 0$$

$$(P - 9)(P - 1) = 0$$

$$P = 1, 9$$

$$9^{\tan^2 x} = 1, 9^{\tan^2 x} = 9$$

$$\tan^2 x = 0, \tan^2 x = 1$$

$$x = 0, \pm \frac{\pi}{4} \therefore x \in \left(-\frac{\pi}{2}, \frac{\pi}{2} \right)$$

$$\beta = \tan^2(0) + \tan^2\left(\frac{\pi}{12}\right) + \tan^2\left(-\frac{\pi}{12}\right)$$

$$= 0 + 2(\tan 15^\circ)^2$$

$$2(2 - \sqrt{3})^2$$

$$2(7 - 4\sqrt{3})$$

$$\text{Then } \frac{1}{6}(14 - 8\sqrt{3} - 14)^2 = 32$$

16. If the coefficients of x and x^2 in $(1+x)^p(1-x)^q$ are 4 and -5 respectively, then $2p+3q$ is equal to

- (1) 63
 (2) 69
 (3) 66
 (4) 60

Official Ans. by NTA (1)

Sol. $(1+x)^p(1-x)^q$

$$\left(1 + px + \frac{p(p-1)}{2!}x^2 + \dots \right)$$

$$\left(1 - qx + \frac{q(q-1)}{2!}x^2 - \dots \right)$$

$$p - q = 4$$

$$\frac{p(p-1)}{2} + \frac{q(q-1)}{2} - pq = -5$$

$$p^2 + q^2 - p - q - 2pq = -10$$

$$(q+4)^2 + q^2 - (q+4) - q - 2(4+q)q = -10$$

$$q^2 + 8q + 16 - q^2 - q - 4 - q - 8q - 2q^2 = -10$$

$$-2q = -22$$

$$q = 11$$

$$p = 15$$

$$2(15) + 3(11)$$

$$30 + 33 = 63$$

17. Let the line $\frac{x}{1} = \frac{6-y}{2} = \frac{z+8}{5}$ intersect the lines $\frac{x-5}{4} = \frac{y-7}{3} = \frac{z+2}{1}$ and $\frac{x+3}{6} = \frac{3-y}{3} = \frac{z-6}{1}$ at the points A and B respectively. Then the distance of the mid-point of the line segment AB from the plane $2x - 2y + z = 14$ is
- (1) 4 (2) $\frac{10}{3}$
(3) 3 (4) $\frac{11}{3}$

Official Ans. by NTA (1)

Sol. $\frac{x}{1} = \frac{y-6}{-2} = \frac{z+8}{5} = \lambda \dots (1)$
 $\frac{x-5}{4} = \frac{y-7}{3} = \frac{z+2}{1} = \mu \dots (2)$
 $\frac{x+3}{4} = \frac{y-3}{-3} = \frac{z-6}{1} = \gamma \dots (3)$

Intersection of (1) & (2) "A"

$(\lambda, -2\lambda + 6, 5\lambda - 8) \& (4\mu + 5, 3\mu + 7, \mu - 2)$

$\lambda = 1, \mu = -1$

A(1, 4, -3)

Intersection of (1) & (3) "B"

$(\lambda, -2\lambda + 6, 5\lambda - 8) \& (6\gamma - 3, -3\gamma + 3, \gamma + 6)$

$\lambda = 3$

$\gamma = 1$

B(3, 0, 7)

Mid point of A & B $\Rightarrow (2, 2, 2)$

Perpendicular distance from the plane

$2x - 2y + z = 14$

$\Rightarrow \left| \frac{2(2) - 2(2) + 2 - 14}{\sqrt{4 + 4 + 1}} \right| = 4$

18. Let $S = \left\{ z = x + iy : \frac{2z - 3i}{4z + 2i} \text{ is a real number} \right\}$.

Then which of the following is NOT correct?

(1) $y + x^2 + y^2 \neq -\frac{1}{4}$

(2) $x = 0$

(3) $(x, y) = \left(0, -\frac{1}{2} \right)$

(4) $y \in \left(-\infty, -\frac{1}{2} \right) \cup \left(-\frac{1}{2}, \infty \right)$

Official Ans. by NTA (3)

Sol. $\frac{2z - 3i}{4z + 2i} \in \mathbb{R}$

$\frac{2(x + iy) - 3i}{4(x + iy) + 2i} = \frac{2x + (2y - 3)i}{4x + (4y + 2)i} \times \frac{4x - (4y + 2)i}{4x - (4y + 2)i}$

$4x(2y - 3) - 2x(4y + 2) = 0$

$x = 0 \quad y \neq -\frac{1}{2}$

Ans. = 3

19. Let the number $(22)^{2022} + (2022)^{22}$ leave the remainder α when divided by 3 and β when divided by 7. Then $(\alpha^2 + \beta^2)$ is equal to

(1) 10

(2) 5

(3) 20

(4) 13

Official Ans. by NTA (2)

Sol. $(22)^{2022} + (2022)^{22}$

divided by 3

$(21 + 1)^{2022} + (2022)^{22}$

$= 3k + 1 \quad (\alpha = 1)$

Divided by 7

$(21 + 1)^{2022} + (2023 - 1)^{22}$

$7k + 1 + 1 \quad (\beta = 2)$

$7k + 2$

So $\alpha^2 + \beta^2 \Rightarrow 5$

20. Let μ be the mean and σ be the standard deviation of the distribution

x_i	0	1	2	3	4	5
f_i	$k + 2$	$2k$	$k^2 - 1$	$k^2 - 1$	$k^2 + 1$	$k - 3$

where $\sum f_i = 62$. if $[x]$ denotes the greatest integer

$\leq x$, then $[\mu^2 + \sigma^2]$ is equal

(1) 8

(2) 7

(3) 6

(4) 9

Official Ans. by NTA (1)

Sol. $\sum f_i = 62$
 $\Rightarrow 3k^2 + 16k - 12k - 64 = 0$
 $\Rightarrow k = \text{or } -\frac{16}{3}$ (rejected)
 $\mu = \frac{\sum f_i x_i}{\sum f_i}$
 $\mu = \frac{8 + 2(15) + 3(15) + 4(17) + 5}{62} = \frac{156}{62}$
 $\sigma^2 = \sum f_i x_i^2 - \left(\sum f_i x_i\right)^2$
 $= \frac{8 \times 1^2 + 15 \times 13 + 17 \times 16 + 25}{62} - \left(\frac{156}{62}\right)^2$
 $\sigma^2 = \frac{500}{62} - \left(\frac{156}{62}\right)^2$
 $\sigma^2 + \mu^2 = \frac{500}{62}$
 $[\sigma^2 + \mu^2] = 8$

SECTION-B

21. Let the equations of two adjacent sides of a parallelogram ABCD be $2x - 3y = -23$ and $5x + 4y = 23$. If the equation of its one diagonal AC is $3x + 7y = 23$ and the distance of A from the other diagonal is d, then $50 d^2$ is equal to _____.

Official Ans. by NTA (529)

Sol.

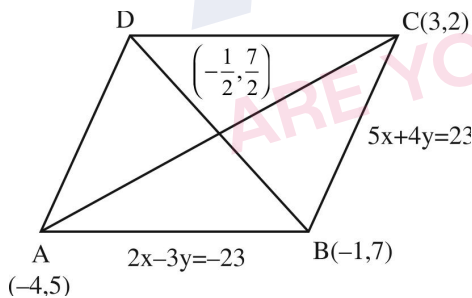

A & C point will be $(-4, 5)$ & $(3, 2)$

mid point of AC will be $\left(-\frac{1}{2}, \frac{7}{2}\right)$

equation of diagonal BD is

$$y - \frac{7}{2} = \frac{\frac{7}{2} - 5}{-\frac{1}{2} - (-4)} \left(x + \frac{1}{2}\right)$$

$\Rightarrow 7x + y = 0$

Distance of A from diagonal BD

$$= d = \frac{23}{\sqrt{50}}$$

$\Rightarrow 50d^2 = (23)^2$
 $50d^2 = 529$

22. Let S be the set of values of λ , for which the system of equations

$$6\lambda x - 3y + 3z = 4\lambda^2,$$

$$2x + 6\lambda y + 4z = 1,$$

$$3x + 2y + 3\lambda z = \lambda \text{ has no solution. Then } 12 \sum_{\lambda \in S} |\lambda|$$

is equal to _____.

Official Ans. by NTA (24)

Sol. $\Delta = \begin{vmatrix} 6\lambda & -3 & 3 \\ 2 & 6\lambda & 4 \\ 3 & 2 & 3\lambda \end{vmatrix} = 0$ (For No Solution)

$$2\lambda(9\lambda^2 - 4) + (3\lambda - 6) + (2 - 9\lambda) = 0$$

$$18\lambda^3 - 14\lambda - 4 = 0$$

$$(\lambda - 1)(3\lambda + 1)(3\lambda + 2) = 0$$

$$\Rightarrow \lambda = 1, -1/3, -2/3$$

For each λ , $\Delta_1 = \begin{vmatrix} 6\lambda & -3 & 4\lambda^2 \\ 2 & 6\lambda & 1 \\ 3 & 2 & \lambda \end{vmatrix} \neq 0$

Ans. $12 \left(1 + \frac{1}{3} + \frac{2}{3}\right) = 24$

23. Let the foot of perpendicular from the point A(4, 3, 1) on the plane P : $x - y + 2z + 3 = 0$ be N. If B(5, α , β), $\alpha, \beta \in \mathbb{Z}$ is a point on plane P such that the

area of the triangle ABN is $3\sqrt{2}$, then $\alpha^2 + \beta^2 + \alpha\beta$ is equal to _____.

Official Ans. by NTA (7)

Sol.

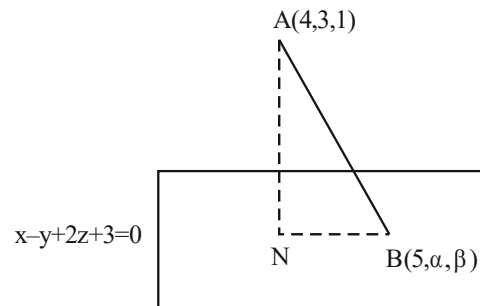

$$AN = \sqrt{6}$$

$$5 - \alpha + 2\beta + 3 = 0$$

$\Rightarrow \alpha = 8 + 2\beta \dots (1)$

N is given by

$$\frac{x-4}{1} = \frac{y-3}{-1} = \frac{z-1}{2} = \frac{-(4-3+2+3)}{1+1+4}$$

$$\Rightarrow x = 3, y = 4, z = -1$$

$$\Rightarrow N \text{ is } (3, 4, -1)$$

$$BN = \sqrt{4 + (\alpha - 4)^2 + (\beta + 1)^2}$$

$$= \sqrt{4 + (2\beta + 4)^2 + (\beta + 1)^2}$$

$$\text{Area of } \triangle ABN = \frac{1}{2} AN \times BN = 3\sqrt{2}$$

$$\Rightarrow \frac{1}{2} \times \sqrt{6} \times BN = 3\sqrt{2}$$

$$BN = 2\sqrt{3}$$

$$\Rightarrow 4 + (2\beta + 4)^2 + (\beta + 1)^2 = 12$$

$$(2\beta + 4)^2 + (\beta + 1)^2 - 8 = 0$$

$$5\beta^2 + 18\beta + 9 = 0$$

$$(5\beta + 3)(\beta + 3) = 0$$

$$\beta = -3$$

$$\Rightarrow \alpha = 2$$

$$\Rightarrow \alpha^2 + \beta^2 + \alpha\beta = 9 + 4 - 6 = 7$$

24. Let quadratic curve passing through the point $(-1, 0)$ and touching the line $y = x$ at $(1, 1)$ be $y = f(x)$. Then the x-intercept of the normal to the curve at the point $(\alpha, \alpha + 1)$ in the first quadrant is _____.

Official Ans. by NTA (11)

Sol. $f(x) = (x + 1)(ax + b)$

$$1 = 2a + 2b \quad (1)$$

$$f'(x) = (ax + b) + a(x + 1)$$

$$1 = (3a + b) \quad (2)$$

$$\Rightarrow b = 1/4, a = 1/4$$

$$f(x) = \frac{(x+1)^2}{4}$$

$$f'(x) = \frac{x}{2} + \frac{1}{2} \quad \alpha + 1 = \frac{(\alpha + 1)^2}{4}, \alpha > -1$$

$$\alpha + 1 = 4$$

$$\alpha = 3$$

normal at $(3, 4)$

$$y - 4 = -\frac{1}{2}(x - 3)$$

$$y = 0 \quad x = 8 + 3$$

Ans. 11

25. Let the tangent at any point P on a curve passing through the points $(1, 1)$ and $(\frac{1}{10}, 100)$, intersect positive x-axis and y-axis at the points A and B respectively. If $PA : PB = 1 : k$ and $y = y(x)$ is the solution of the differential equation $e^{\frac{dy}{dx}} = kx + \frac{k}{2}$, $y(0) = k$, then $4y(1) - 5\log_e 3$ is equal to _____.

Official Ans. by NTA (6)

Sol. equation of tangent at P (x, y)

$$Y - y = \frac{dy}{dx}(X - x)$$

$$Y = 0$$

$$X = \frac{-y dx}{dy} + x$$

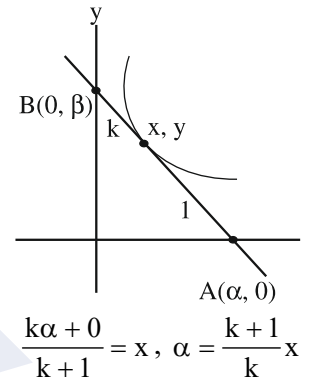

$$\frac{k+1}{k}x = -y \frac{dx}{dy} + x$$

$$x + \frac{x}{k} = -y \frac{dx}{dy} + x$$

$$x \frac{dy}{dx} + ky = 0$$

$$\frac{dy}{dx} + \frac{k}{x}y = 0$$

$$y \cdot x^k = C$$

$$C = 1$$

$$100 \cdot \left(\frac{1}{10}\right)^k = 1$$

$$k = 2$$

$$\frac{dy}{dx} = \ln(2x + 1)$$

$$y = \frac{(2x + 1)}{2} (\ln(2x + 1) - 1) + c$$

$$2 = \frac{1}{2}(0 - 1) + C$$

$$C = 2 + \frac{1}{2} = \frac{5}{2}$$

$$y(1) = \frac{3}{2}(\ln 3 - 1) + \frac{5}{2}$$

$$= \frac{3}{2} \ln 3 + 1$$

$$4y(1) = 6 \ln 3 + 4$$

$$4y(1) - 5 \ln 3 = 4 + \ln 3$$

26. Suppose a_1, a_2, a_3, a_4 be in an arithmetico-geometric progression. If the common ratio of the corresponding geometric progression is 2 and the sum of all 5 terms of the arithmetico-geometric progression is $\frac{49}{2}$, then a_4 is equal to _____.

Official Ans. by NTA (16)

Sol. $\frac{(a - 2d)}{4}, \frac{(a - d)}{2}, a, 2(a + d), 4(a + 2d)$

$a = 2$

$\left(\frac{1}{4} + \frac{1}{2} + 1 + 6\right) \times 2 + (-1 + 2 + 8)d = \frac{49}{2}$

$2\left(\frac{3}{4} + 7\right) + 9d = \frac{49}{2}$

$9d = \frac{49}{2} - \frac{62}{4} = \frac{98 - 62}{4} = 9$

$d = 1$

$\Rightarrow a_4 = 4(a + 2d) = 16$

27. If the domain of the function $f(x) = \sec^{-1}\left(\frac{2x}{5x+3}\right)$ is $[\alpha, \beta] \cup (\gamma, \delta]$, then $|3\alpha + 10(\beta + \gamma) + 21\delta|$ is equal to _____.

Official Ans. by NTA (24)

Sol. $f(x) = \sec^{-1}\frac{2x}{5x+3}$

$\left|\frac{2x}{5x+3}\right|$

$\left|\frac{2x}{5x+3}\right| \geq 1 \Rightarrow |2x| \geq |5x+3|$

$(2x)^2 - (5x+3)^2 \geq |5x+3|$

$(7x+3)(-3x-3) \geq 0$

$\frac{-}{-1} + \frac{-}{-\frac{3}{7}}$

\therefore domain $\left[-1, \frac{-3}{5}\right] \cup \left(\frac{-3}{5}, \frac{-3}{7}\right]$

$\alpha = -1, \beta = \frac{-3}{5}, \gamma = \frac{-3}{5}, \delta = \frac{-3}{7}$

$3\alpha + 10(\beta + \gamma) + 21\delta = -3$

$-3 + 10\left(\frac{-6}{5}\right) + \left(\frac{-3}{7}\right) 21 = -24$

28. The sum of all the four-digit numbers that can be formed using all the digits 2, 1, 2, 3 is equal to _____.

Official Ans. by NTA (26664)

Sol. 2, 1, 2, 3

— — — $\frac{1}{2!} = 3$

— — — $\frac{2}{3!} = 6$

— — — $\frac{3}{2!} = 3$

Sum of digits of unit place = $3 \times 1 + 6 \times 2 + 3 \times 3 = 24$

\therefore required sum

$= 24 \times 1000 + 24 \times 100 + 24 \times 10 + 24 \times 1$

$= 24 \times 1111$

Ans ; 26664

29. In the figure, $\theta_1 + \theta_2 = \frac{\pi}{2}$ and $\sqrt{3}(BE) = 4(AB)$.

If the area of ΔCAB is $2\sqrt{3} - 3$ unit², when $\frac{\theta_2}{\theta_1}$ is

the largest, then the perimeter (in unit) of ΔCED is equal to _____.

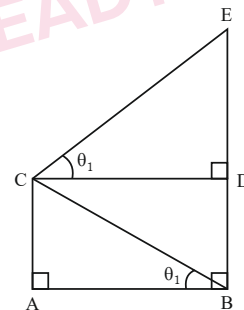

Official Ans. by NTA (6)

Sol.

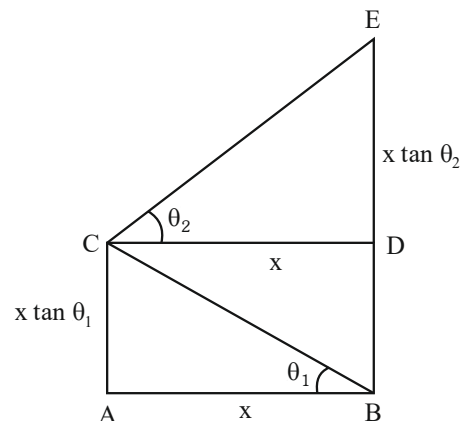

$$\sqrt{3} BE = 4 AB$$

$$\text{Ar}(\Delta CAB) = 2\sqrt{3} - 3$$

$$\frac{1}{2}x^2 \tan \theta_1 = 2\sqrt{3} - 3$$

$$BE = BD + DE$$

$$= x (\tan \theta_1 + \tan \theta_2)$$

$$BE = AB (\tan \theta_1 + \cot \theta_1)$$

$$\frac{4}{\sqrt{3}} \tan \theta_1 + \cot \theta_1 \Rightarrow \tan \theta_1 = \sqrt{3}, \frac{1}{\sqrt{3}}$$

$$\theta_1 = \frac{\pi}{6}$$

$$\theta_2 = \frac{\pi}{3}$$

$$\theta_1 = \frac{\pi}{3}$$

$$\theta_2 = \frac{\pi}{6}$$

$$\text{as } \frac{\theta_2}{\theta_1} \text{ is largest } \therefore \theta_1 = \frac{\pi}{6} \quad \theta_2 = \frac{\pi}{3}$$

$$\therefore x^2 = \frac{(2\sqrt{3} - 3) \times 2}{\tan \theta_1} = \frac{\sqrt{3}(2 - \sqrt{3}) \times 2}{\tan \frac{\pi}{6}}$$

$$x^2 = 12 - 6\sqrt{3} = (3 - \sqrt{3})^2$$

$$x = 3 - \sqrt{3}$$

Perimeter of ΔCED

$$= CD + DE + CE$$

$$= 3\sqrt{3} + (3 - \sqrt{3})\sqrt{3} + (3 - \sqrt{3}) \times 2 = 6$$

Ans : 6

30. If the area of the region $(x, y) : |x^2 - 2| \leq y \leq x$ is A, then $6A + 16\sqrt{2}$ is equal to _____ .

Official Ans. by NTA (27)

Sol. $|x^2 - 2| \leq y \leq x$

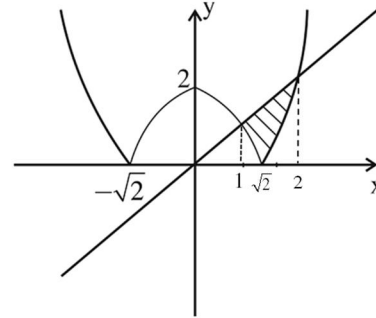

$$A = \int_{-1}^{\sqrt{2}} (x - (2 - x^2)) dx + \int_{\sqrt{2}}^2 (x - (x^2 - 2)) dx$$

$$= \left(1 - 2\sqrt{2} + \frac{2\sqrt{2}}{3}\right) - \left(\frac{1}{2} - 2 + \frac{1}{3}\right) + \left(2 - \frac{8}{3} + 4\right) - \left(1 - \frac{2\sqrt{2}}{3} + 2\sqrt{2}\right)$$

$$= -4\sqrt{2} + \frac{4\sqrt{2}}{3} + \frac{7}{6} + \frac{10}{3} = \frac{-8\sqrt{2}}{3} + \frac{9}{2}$$

$$6A = -16\sqrt{2} + 27 \quad \therefore 6A + 16\sqrt{2} = 27$$

Ans : 27

PHYSICS

TEST PAPER WITH SOLUTION

SECTION-A

31. A person travels x distance with velocity v_1 and then x distance with velocity v_2 in the same direction. The average velocity of the person is v , then the relation between v , v_1 and v_2 will be :

- (1) $v = v_1 + v_2$
- (2) $v = \frac{v_1 + v_2}{2}$
- (3) $\frac{2}{v} = \frac{1}{v_1} + \frac{1}{v_2}$
- (4) $\frac{1}{v} = \frac{1}{v_1} + \frac{1}{v_2}$

Official Ans. by NTA (3)

Sol. Average velocity = $\frac{x+x}{\frac{x}{v_1} + \frac{x}{v_2}} = v$

$$\frac{1}{v_1} + \frac{1}{v_2} = \frac{2}{v}$$

32. The half-life of a radioactive substance is T . The time taken, for disintegrating $\frac{7}{8}$ th part of its original mass will be :

- (1) $3T$
- (2) $8T$
- (3) T
- (4) $2T$

Official Ans. by NTA (1)

Sol. $t_{1/2} = T$

$$1 \xrightarrow{T} \frac{1}{2} \xrightarrow{T} \frac{1}{4} \xrightarrow{T} \frac{1}{8}$$

$t_{7/8} = 3T$

33. A gas mixture consists of 2 moles of oxygen and 4 moles of neon at temperature T . Neglecting all vibrational modes, the total internal energy of the system will be :

- (1) $8 RT$
- (2) $16 RT$
- (3) $4 RT$
- (4) $11 RT$

Official Ans. by NTA (4)

Sol. $(C_v)_{\text{mix}} = \frac{n_1 C_{v1} + n_2 C_{v2}}{n_1 + n_2}$

$$(C_v)_{\text{mix}} = \frac{2 \times \frac{5}{2} R + 4 \times \frac{3}{2} R}{2 + 4} = \frac{11R}{6}$$

$$\Delta U = n(C_v)_{\text{mix}} RT = 6 \frac{11R}{6} \times RT = 11R$$

34. In an experiment with Vernier callipers of least count 0.1 mm , when two jaws are joined together the zero of Vernier scale lies right to the zero of the main scale and 6^{th} division of Vernier scale coincides with the main scale division. While measuring the diameter of a spherical bob, the zero of vernier scale lies in between 3.2 cm and 3.3 cm marks, and 4^{th} division of vernier scale coincides with the main scale division. The diameter of bob is measured as :

- (1) 3.18 cm
- (2) 3.25 cm
- (3) 3.26 cm
- (4) 3.22 cm

Official Ans. by NTA (1)

Sol. $LC = 0.1 \text{ mm}$

Zero Error = $6 \times LC = 0.6 \text{ mm}$

Reading = $MSR + VSR \times LC - \text{Zero Error}$

$$= [32 \text{ mm} + (0.1)4 \text{ mm}] - 0.6 \text{ mm}$$

$$= 31.8 \text{ mm}$$

$$= 3.18 \text{ cm}$$

35. Given below are two statements:

Statement I: For diamagnetic substance $-1 \leq \chi < 0$, where χ is the magnetic susceptibility.

Statement II: Diamagnetic substances when placed in an external magnetic field, tend to move from stronger to weaker part of the field.

In the light of the above statements, choose the correct answer from the options given below.

- (1) Both Statement I and Statement II are false.
- (2) Both Statement I and Statement II are true.
- (3) Statement I is incorrect but Statement II is true.
- (4) Statement I is correct but Statement II is false.

Official Ans. by NTA (2)

Sol. Both Statements are correct.

36. The distance between two plates of a capacitor is d and its capacitance is C_1 , when air is the medium between the plates. If a metal sheet of thickness $\frac{2d}{3}$ and of same area as plate is introduced between the plates, the capacitance of the capacitor becomes C_2 . The ratio $\frac{C_2}{C_1}$ is:

- (1) 2 : 1
- (2) 4 : 1
- (3) 3 : 1
- (4) 1 : 1

Official Ans. by NTA (3)

Sol. $K_{\text{metal sheet}} = \infty$, $t = \frac{2d}{3}$

$$C_1 = \frac{\epsilon_0 A}{d}$$

$$C_2 = \frac{\epsilon_0 A}{d - t + \frac{t}{k}} = \frac{\epsilon_0 A}{d - \frac{2d}{3} + 0} = 3C_1$$

$$\frac{C_2}{C_1} = 3$$

37. Given below are two statements:

Statement I: Rotation of the earth shows effect on the value of acceleration due to gravity (g).

Statement II: The effect of rotation of the earth on the value of ' g ' at the equator is minimum and that at the pole is maximum.

In the light of the above statements, choose the correct answer from the options given below.

- (1) Statement I is false but Statement II is true.
- (2) Statement I is true but Statement II are false.
- (3) Both Statement I and Statement II are true.
- (4) Both Statement I and Statement II are false.

Official Ans. by NTA (2)

Sol. Statement I is true due to centrifugal force.

Statement II is incorrect,

At pole $g = g_s$ (no effect)

At equator $g = g_s - r\omega^2 \cos^2 \lambda = g_s - r\omega^2$

$\therefore (\cos^2 \lambda)_{\text{maximum}}$ at $\lambda = 0^\circ$ i.e. at equator)

Effect is maximum at equator.

38. The time period of a satellite, revolving above earth's surface at a height equal to R will be (Given $g = \pi^2 \text{ m/s}^2$, $R = \text{radius of earth}$)

- (1) $\sqrt{4R}$
- (2) $\sqrt{8R}$
- (3) $\sqrt{32R}$
- (4) $\sqrt{2R}$

Official Ans. by NTA (3)

Sol. $\frac{mv^2}{2R} = \frac{GMm}{(2R)^2} \Rightarrow v = \sqrt{\frac{GM}{2R}} = \sqrt{\frac{Rg}{2}}$

$$T = \frac{2\pi(2R)}{v} = \frac{4\pi R \sqrt{2}}{\sqrt{Rg}} = \sqrt{32R}$$

39. Given below are two statements: one is labelled as **Assertion A** and the other is labelled as **Reason R**.
Assertion A: An electric fan continues to rotate for some time after the current is switched off.

Reason R: Fan continues to rotate due to inertia of motion.

In the light of above statements, choose the most appropriate answer from the options given below.

- (1) **A** is correct but **R** is not correct.
- (2) Both **A** and **R** are correct and **R** is the correct explanation of **A**.
- (3) **A** is not correct but **R** is correct.
- (4) Both **A** and **R** are correct but **R** is **NOT** the correct explanation of **A**.

Official Ans. by NTA (2)

Sol. Fact

40. The amplitude of magnetic field in an electromagnetic wave propagating along y-axis is 6.0×10^{-7} T. The maximum value of electric field in the electromagnetic wave is:

- (1) $5 \times 10^{14} \text{ Vm}^{-1}$
- (2) 180 Vm^{-1}
- (3) $2 \times 10^{15} \text{ Vm}^{-1}$
- (4) $6.0 \times 10^{-7} \text{ Vm}^{-1}$

Official Ans. by NTA (2)

Sol. $\frac{E}{B} = C$

$E = BC$

$= 6 \times 10^{-7} \times 3 \times 10^8$

$= 18 \times 10$

$E = 180 \text{ Vm}^{-1}$

41. A gas is compressed adiabatically, which one of the following statement is NOT true.

- (1) There is no heat supplied to the system
- (2) The temperature of the gas increases
- (3) The change in the internal energy is equal to the work done on the gas.
- (4) There is no change in the internal energy

Official Ans. by NTA (4)

Sol. (1) $\Delta Q = 0$
 (2) $\Delta Q = \Delta U + \Delta W$
 $\Rightarrow \Delta U = -\Delta W$
 adiabatic compression ($V \downarrow$)
 $\Delta W = -ve \Rightarrow \Delta U = +ve$
 $\Delta U \uparrow \Rightarrow T \uparrow$
 $\Delta U \neq 0$

42. The ratio of intensities at two points P and Q on the screen in a Young's double slit experiment where phase difference between two wave of same amplitude are $\pi/3$ and $\pi/2$, respectively are

- (1) 1 : 3
- (2) 3 : 1
- (3) 3 : 2
- (4) 2 : 3

Official Ans. by NTA (3)

Sol. $I_{\text{net}} = I_1 + I_2 + 2\sqrt{I_1 I_2} \cos \phi$
 $= I_0 + I_0 + 2I_0 \cos \frac{\pi}{3}$
 $= 2I_0 + 2I_0 \times \frac{1}{2} = 3I_0$
 $I_{\text{net}} = I_0 + I_0 + 2I_0 \cos 90^\circ = 2I_0$
 Ratio = $\frac{3}{2}$

43. The variation of stopping potential (V_0) as a function of the frequency (ν) of the incident light for a metal is shown in figure. The work function of the surface is

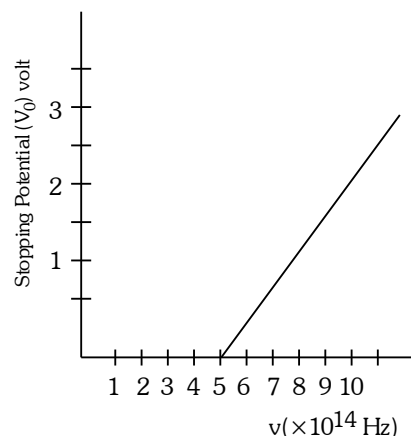

- (1) 18.6 eV
- (2) 2.98 eV
- (3) 2.07 eV
- (4) 1.36 eV

Official Ans. by NTA (3)

49. If each diode has a forward bias resistance of $25\ \Omega$ in the below circuit,

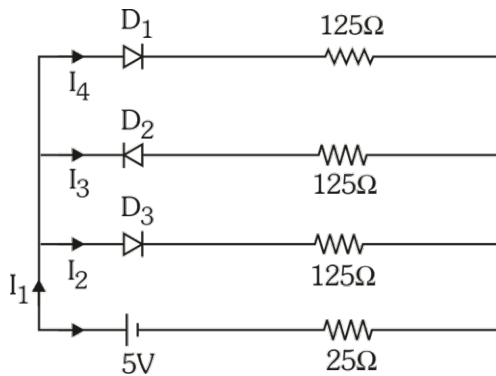

Which of the following options is correct:

- (1) $\frac{I_3}{I_4} = 1$ (2) $\frac{I_2}{I_3} = 1$
(3) $\frac{I_1}{I_2} = 1$ (4) $\frac{I_1}{I_2} = 2$

Official Ans. by NTA (4)

Sol.

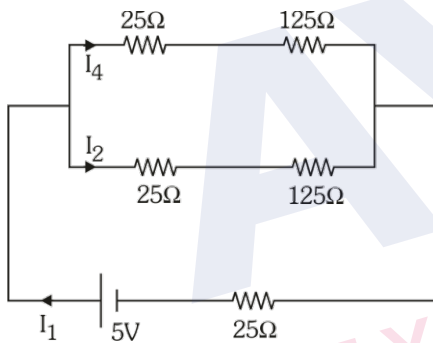

$$R_{eq} = \frac{150 \times 150}{300} + 25 = 100\ \Omega$$

$$I_1 = \frac{5}{100} = 0.05\text{A}$$

$$I_2 = I_4 = \frac{0.05}{2} = 0.025\text{A}$$

$$\frac{I_1}{I_2} = 2$$

50. A bar magnet is released from rest along the axis of a very long vertical copper tube. After some time the magnet will
- (1) Move down with almost constant speed
 - (2) Oscillate inside the tube
 - (3) Move down with an acceleration greater than g
 - (4) Move down with an acceleration equal to g

Official Ans. by NTA (1)

Sol. After some time both force becomes equal.

SECTION-B

51. A square loop of side 2.0 cm is placed inside a long solenoid that has 50 turns per centimetre and carries a sinusoidally varying current of amplitude 2.5 A and angular frequency $700\ \text{rad s}^{-1}$. The central axes of the loop and solenoid coincide. The amplitude of the emf induced in the loop is $x \times 10^{-4}\ \text{V}$. The value of x is _____

(Take, $\pi = \frac{22}{7}$)

Official Ans. by NTA (44)

Sol.

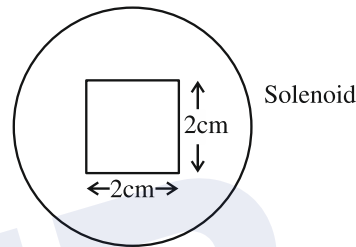

$$B_{\text{due to solenoid}} = \mu_0 n I$$

$$\Phi_{\text{through square}} = \mu_0 n I \times A \quad (A = \text{Area})$$

$$\text{Emf} = \mu_0 n A \times \frac{dI}{dt}$$

$$= \mu_0 n A \times I_0 \omega \cos \omega t$$

$$\text{Emf amplitude} = \mu_0 n A \times I_0 \omega$$

$$= 4\pi \times 10^{-7} \times \frac{50}{10^{-2}} \times 4 \times 10^{-4} \times 2.5 \times 700$$

$$= 44 \times 10^{-4}\ \text{V}$$

52. A rectangular block of mass 5 kg attached to a horizontal spiral spring executes simple harmonic motion of amplitude 1 m and time period 3.14 s. The maximum force exerted by spring on block is _____ N.

Official Ans. by NTA (20)

Sol. $\therefore T = 3.14 = \pi$

$$T = \pi = \frac{2\pi}{\omega} \Rightarrow \omega = 2$$

$$\begin{aligned} F_{\text{max}} &= m a_{\text{max}} \\ &= m (A\omega^2) \\ &= mA (2)^2 \\ &= 5 \times 1 \times 4 \\ &= 20\ \text{N} \end{aligned}$$

53. If 917 \AA be the lowest wavelength of Lyman series then the lowest wavelength of Balmer series will be _____ \AA .

Official Ans. by NTA (3668)

Sol. For lowest wavelength of Lyman series

$$\frac{1}{\lambda} = RZ^2 \left[\frac{1}{1^2} - \frac{1}{\infty^2} \right] = RZ^2$$

For lowest wavelength of Balmer series

$$\frac{1}{\lambda'} = RZ^2 \left[\frac{1}{2^2} - \frac{1}{\infty^2} \right] = \frac{RZ^2}{4}$$

$$\lambda' = \frac{4}{RZ^2} = 4 \times 917 = 3668 \text{ \AA}$$

54. Figure below shows a liquid being pushed out of the tube by a piston having area of cross section 2.0 cm^2 . The area of cross section at the outlet is 10 mm^2 . If the piston is pushed at a speed of 4 cm s^{-1} , the speed of outgoing fluid is _____ cm s^{-1} .

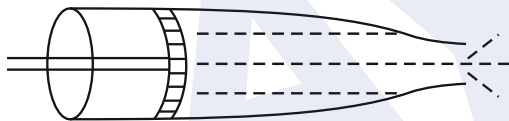

Official Ans. by NTA (80)

Sol. By equation of continuity

$$A_1 V_1 = A_2 V_2$$

$$V_2 = \frac{2 \times 4}{10 \times 10^{-2}} = 80 \text{ cm/s}$$

55. A straight wire carrying a current of 14 A is bent into a semicircular arc of radius 2.2 cm as shown in the figure. The magnetic field produced by the current at the centre (O) of the arc, is _____ $\times 10^{-4} \text{ T}$

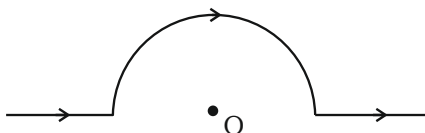

Official Ans. by NTA (2)

Sol.
$$B_{\text{at } O} = \frac{\mu_0 I}{4R} = \frac{4\pi \times 10^{-7} \times 14}{4 \times 2.2 \times 10^{-2}} = 2 \times 10^{-4} \text{ T}$$

56. A point object, 'O' is placed in front of two thin symmetrical coaxial convex lenses L_1 and L_2 with focal length 24 cm and 9 cm respectively. The distance between two lenses is 10 cm and the object is placed 6 cm away from lens L_1 as shown in the figure. The distance between the object and the image formed by the system of two lenses is _____ cm .

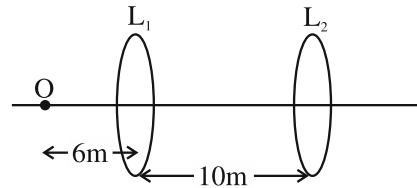

Official Ans. by NTA (34)

From Ist lens $\frac{1}{v} + \frac{1}{6} = \frac{1}{24}$

$$\frac{1}{v} = \frac{1}{24} - \frac{1}{6} = -\frac{1}{8}$$

$$v = -8 \text{ cm}$$

From IInd lens $\frac{1}{v} + \frac{1}{18} = \frac{1}{9}$

$$\frac{1}{v} = \frac{1}{18}$$

$$v = 18$$

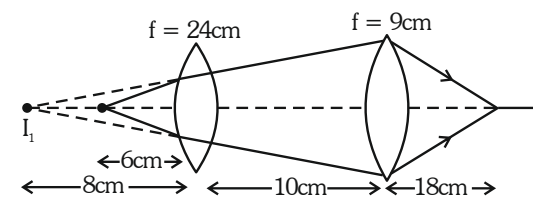

So distance between object and its image
 $= 6 + 10 + 18 = 34 \text{ cm}$

57. A rectangular parallelepiped is measured as $1 \text{ cm} \times 1 \text{ cm} \times 100 \text{ cm}$. If its specific resistance is $3 \times 10^{-7} \Omega \text{ m}$, then the resistance between its two opposite rectangular faces will be _____ $\times 10^{-7} \Omega$.

Official Ans. by NTA (3)

Sol.

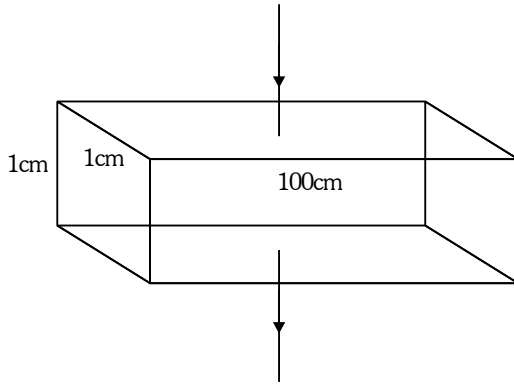

$$R = \rho \frac{\ell}{A} = \frac{3 \times 10^{-7} \times (1 \times 10^{-2})}{100 \times 1 \times 10^{-4}}$$

$$= 3 \times 10^{-7} \Omega$$

58. A force of $-P\hat{k}$ acts on the origin of the coordinate system. The torque about the point $(2, -3)$ is $P(a\hat{i} + b\hat{j})$, the ratio of $\frac{a}{b}$ is $\frac{x}{2}$. The value of x is

Official Ans. by NTA (3)

Sol. $\vec{\tau} = \vec{r} \times \vec{F}$

Where $\vec{r} = -2\hat{i} + 3\hat{j}$

$$\tau = (-2\hat{i} + 3\hat{j}) \times (-P\hat{k})$$

$$= P(-2\hat{j} - 3\hat{i}) = P(-3\hat{i} - 2\hat{j})$$

\Rightarrow So $a = -3, b = -2$

$$\frac{a}{b} = \frac{3}{2}$$

59. If the maximum load carried by an elevator is 1400 kg (600 kg – Passenger + 800 kg – elevator), which is moving up with a uniform speed of 3 ms^{-1} and the frictional force acting on it is 2000 N, then the maximum power used by the motor is _____ kW ($g = 10 \text{ m/s}^2$).

Official Ans. by NTA (48)

Sol. $P_{\max} = F_{\max} \times v$

$$F_{\max} = 1400 \text{ g} + \text{friction}$$

$$= 14000 + 2000 = 16000$$

$$P_{\max} = 16000 \times 3 = 48000 \text{ W} = 48 \text{ KW}$$

60. An electron revolves around an infinite cylindrical wire having uniform linear charge density $2 \times 10^{-8} \text{ Cm}^{-1}$ in circular path under the influence of attractive electrostatic field as shown in the figure. The velocity of electron with which it is revolving is _____ $\times 10^6 \text{ ms}^{-1}$. Given mass of electron = $9 \times 10^{-31} \text{ kg}$.

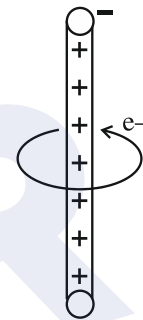

Official Ans. by NTA (8)

Sol.

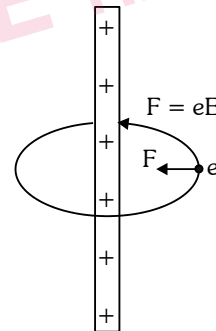

$$eE = \frac{mV^2}{r}$$

$$e \cdot \frac{2K\lambda}{r} = \frac{mV^2}{r}$$

$$V = \sqrt{\frac{e \cdot 2k\lambda}{m}}$$

$$= \sqrt{\frac{1.6 \times 10^{-19} \times 2 \times 9 \times 10^9 \times 2 \times 10^{-8}}{9 \times 10^{-31}}}$$

$$= 8 \times 10^6 \text{ m/s}$$

CHEMISTRY

SECTION-A

61. Incorrect method of preparation for alcohols from the following is:
 (1) Ozonolysis of alkene.
 (2) Reaction of Ketone with RMgBr followed by hydrolysis.
 (3) Hydroboration-oxidation of alkene.
 (4) Reaction of alkyl halide with aqueous NaOH.

Official Ans. by NTA (1)

Sol. Ozonolysis of alkene, gives aldehyde, ketone & carboxylic acid.

62. Given below are two statements: one is labelled as **Assertion A** and the other is labelled as **Reason R**.
Assertion A: The energy required to form Mg^{2+} from Mg is much higher than that required to produce Mg^+ .

Reason R: Mg^{2+} is small ion and carry more charge than Mg^+ .

In the light of the above statements, choose the **correct** answer from the options given below:

- (1) Both A and R are true but R is NOT the correct explanation of A.
 (2) A is true but R is false.
 (3) A is false but R is true.
 (4) Both A and R are true and R is the correct explanation of A.

Official Ans. by NTA (4)

Sol. Assertion & Reason are correct and Reason is correct explanation.

∴ Successive I.E. always increases.

63. In Carius tube, an organic compound 'X' is treated with sodium peroxide to form a mineral acid 'Y'. The solution of $BaCl_2$ is added to 'Y' to form a precipitate 'Z'. 'Z' is used for the quantitative estimation of an extra element. 'X' could be:

- (1) Cytosine (2) Chloroxylenol
 (3) A nucleotide (4) Methionine

Official Ans. by NTA (4)

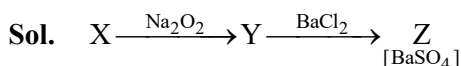

Methionine: $C_5H_{11}NO_2S$

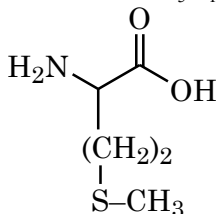

TEST PAPER WITH SOLUTION

64. Given below are two statements: one is labelled as **Assertion A** and the other is labelled as **Reason R**.
Assertion A: 3.1500g of hydrated oxalic acid dissolved in water to make 250.0 mL solution will result in 0.1 M oxalic acid solution.

Reason R: Molar mass of hydrated oxalic acid is 126 g mol^{-1} .

In the light of the above statements, chose the correct answer from the options given below:

- (1) Both A and R are true but R is NOT the correct explanation of A.
 (2) A is false but R is true.
 (3) A is true but R is false.
 (4) Both A and R are true and R is the correct explanation of A.

Official Ans. by NTA (4)

Sol. Assertion is correct.



$$M = \frac{3.15 \times 1000}{126 \times 250} \\
 = \frac{12.6}{126} = 0.1$$

Reason is correct. It is used as a fact in explanation of assertion.

65. Buna-S can be represented as:

- (1) $\left[\text{CH}=\text{CH}-\text{CH}=\text{CH}-\overset{\text{C}_6\text{H}_5}{\underset{|}{\text{C}}}-\text{CH}_2 \right]_n$
 (2) $\left[\text{CH}_2-\text{CH}=\text{CH}-\text{CH}_2-\overset{\text{C}_6\text{H}_5}{\underset{|}{\text{C}}}-\text{CH}_2 \right]_n$
 (3) $\left[\text{CH}_2-\text{CH}=\overset{\text{C}_6\text{H}_5}{\underset{|}{\text{C}}}-\text{CH}=\text{CH}-\text{CH}_2 \right]_n$
 (4) $\left[\text{CH}_2-\text{CH}=\text{CH}-\text{CH}=\overset{\text{C}_6\text{H}_5}{\underset{|}{\text{C}}}-\text{CH}_2 \right]_n$

Official Ans. by NTA (2)

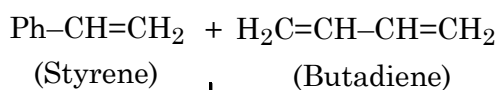

Sol.

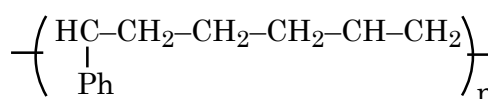

66. In the reaction give below:

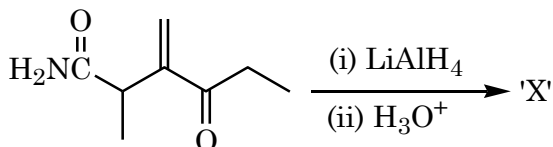

The product 'X' is:

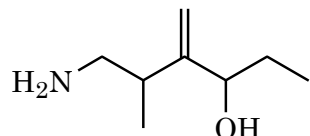
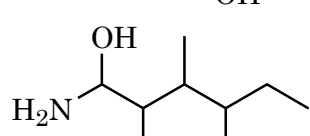
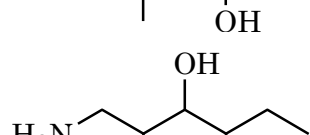
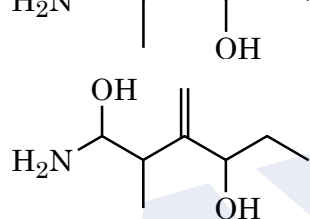
- (1) 
- (2) 
- (3) 
- (4) 

Official Ans. by NTA (1)

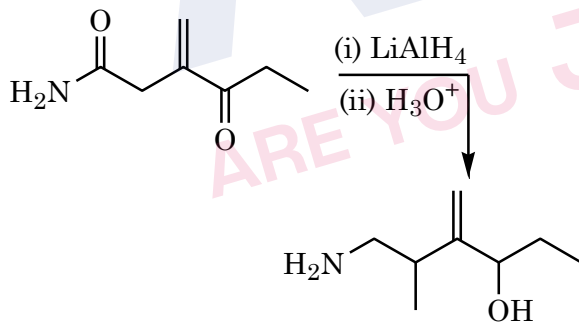

67. Ferric chloride is applied to stop bleeding because:

- (1) Cl^- ions cause coagulation of blood.
- (2) Blood absorbs FeCl_3 and forms a complex.
- (3) Fe^{3+} ions coagulate blood which is a negatively charged sol.
- (4) FeCl_3 reacts with the constituents of blood which is a positively charged sol.

Official Ans. by NTA (3)

Sol. Fe^{3+} coagulation negatively charged sol blood.

68. The reaction used for preparation of soap from fat is:

- (1) reduction reaction
- (2) alkaline hydrolysis reaction
- (3) an addition reaction
- (4) an oxidation reaction

Official Ans. by NTA (2)

Sol. Saponification: Alkaline hydrolysis.

69. The decreasing order of hydride affinity for following carbocations is:

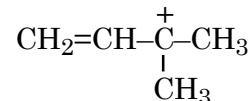
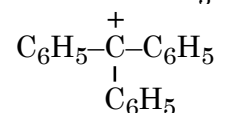
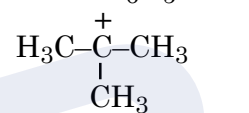
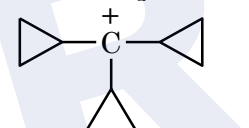
- A. 
- B. 
- C. 
- D. 

Choose the correct answer from the options given below:

- (1) A, C, B, D
- (2) C, A, B, D
- (3) C, A, D, B
- (4) A, C, D, B

Official Ans. by NTA (2)

Sol. Stability order of cations is : $\text{C} < \text{A} < \text{B} < \text{D}$

70. The correct relationship between unit cell edge length 'a' and radius of sphere 'r' for face-centred and body centred cubic structures respectively are:

- (1) $r = 2\sqrt{2}a$ and $\sqrt{3}r = 4a$
- (2) $r = 2\sqrt{2}a$ and $4r = \sqrt{3}a$
- (3) $2\sqrt{2}r = a$ and $4r = \sqrt{3}a$
- (4) $2\sqrt{2}r = a$ and $\sqrt{3}r = 4a$

Official Ans. by NTA (3)

Sol. FCC.

$$a\sqrt{2} = 4r$$

$$r = \frac{a\sqrt{2}}{4}$$

$$\Rightarrow a = 2\sqrt{2}r$$

BCC

$$4r = a\sqrt{3}$$

71. Number of water molecules in washing soda and soda ash respectively are:

- (1) 10 and 1
- (2) 1 and 10
- (3) 1 and 0
- (4) 10 and 0

Official Ans. by NTA (4)

Sol. Washing soda: $\text{Na}_2\text{CO}_3 \cdot 10\text{H}_2\text{O}$
 Soda ash : Na_2CO_3

72. The delicate balance of CO_2 and O_2 is NOT disturbed by:

- (1) Burning of Coal
- (2) Deforestation
- (3) Burning of petroleum
- (4) Respiration

Official Ans. by NTA (4)

Sol. Respiration, is a natural process, So balance of CO_2 and O_2 not disturbed by respiration.

73. The correct order of the number of unpaired electrons in the given complexes is

- A. $[\text{Fe}(\text{CN})_6]^{3-}$
- B. $[\text{FeF}_6]^{3-}$
- C. $[\text{CoF}_6]^{3-}$
- D. $[\text{Cr}(\text{oxalate})_3]^{3-}$
- E. $[\text{Ni}(\text{CO})_4]$



Choose the correct answer from the options given below:

- (1) $A < E < D < C < B$
- (2) $E < A < D < C < B$
- (3) $E < A < B < D < C$
- (4) $A < E < C < B < D$

Official Ans. by NTA (2)

Sol. A. $[\text{Fe}(\text{CN})_6]^{3-}$ $n = 1$
 B. $[\text{FeF}_6]^{3-}$ $n = 5$
 C. $[\text{CoF}_6]^{3-}$ $n = 4$
 D. $[\text{Cr}(\text{oxalate})_3]^{3-}$ $n = 3$
 E. $[\text{Ni}(\text{CO})_4]$ $n = 0$

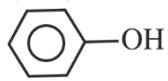
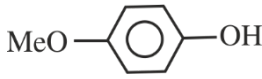
74. The correct order for acidity of the following hydroxyl compound is:

- A. CH_3OH
- B. $(\text{CH}_3)_3\text{COH}$
- C. 
- D. 
- E. 

Choose the correct answer from the options given below:

- (1) $E > C > D > A > B$
- (2) $D > E > C > A > B$
- (3) $C > E > D > B > A$
- (4) $E > D > C > B > A$

Official Ans. by NTA (1)

Sol. $E > C > D > A > B$

75. The major product 'P' formed in the given reaction is:

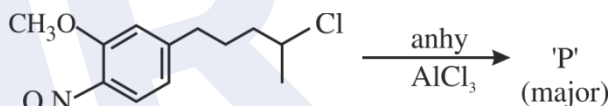

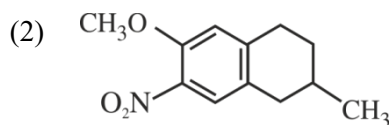
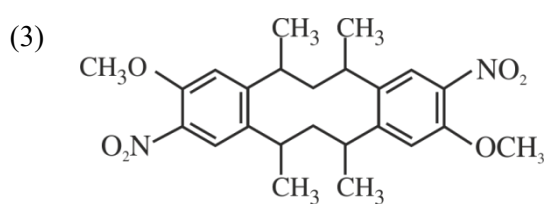
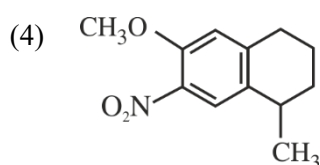
- (1) 
- (2) 
- (3) 
- (4) 

Official Ans. by NTA (4)

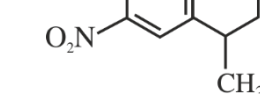
Sol. 

76. Match List I with List II

List I Complex		List II Crystal Field splitting energy (Δ_0)	
A.	$[\text{Ti}(\text{H}_2\text{O})_6]^{2+}$	I.	-1.2
B.	$[\text{V}(\text{H}_2\text{O})_6]^{2+}$	II.	-0.6
C.	$[\text{Mn}(\text{H}_2\text{O})_6]^{3+}$	III.	0
D.	$[\text{Fe}(\text{H}_2\text{O})_6]^{3+}$	IV.	-0.8

Choose the correct answer from the options given below:

- (1) A-II, B-IV, C-I, D-III
- (2) A-IV, B-I, C-II, D-III
- (3) A-IV, B-I, C-III, D-II
- (4) A-II, B-IV, C-III, D-I

Official Ans. by NTA (2)

Sol. A-IV, B-I, C-II, D-III

(A) $[\text{Ti}(\text{H}_2\text{O})_6]^{2+}$

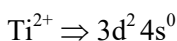

$$t_{2g} e^- = 2$$

$$e_g e^- = 0$$

$$\text{CFSE} = [-0.4 \times 2 + 0.6 \times 0] \Delta_0$$

$$= -0.8 \Delta$$

(B) $[\text{V}(\text{H}_2\text{O})_6]^{2+}$

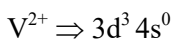

$$t_{2g} e^- = 3$$

$$e_g e^- = 0$$

$$\text{CFSE} = [-0.4 \times 3 + 0.6 \times 0] \Delta_0$$

$$= -1.2 \Delta_0$$

(C) $[\text{Mn}(\text{H}_2\text{O})_6]^{3+}$

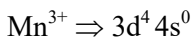

$$t_{2g} e^- = 3$$

$$e_g e^- = 1$$

$$\text{CFSE} = [-0.4 \times 3 + 0.6 \times 1] \Delta_0$$

$$= -0.6 \Delta_0$$

(D) $[\text{Fe}(\text{H}_2\text{O})_6]^{3+}$

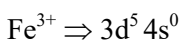

$$t_{2g} e^- = 3 \quad e_g = 2$$

$$\text{CFSE} = [-0.4 \times 3 + 0.6 \times 2] \Delta_0$$

$$= 0 \Delta_0$$

77. Given below are two statements: one is labelled as **Assertion A** and the other is labelled as **Reason R**.
Assertion A: Physical properties of isotopes of hydrogen are different.

Reason: Mass difference between isotopes of hydrogen is very large.

In the light of the above statements, chose the correct answer from the options given below:

- (1) A is false but R is true.
- (2) Both A and R are true and R is the NOT the correct explanation of A.
- (3) A is true but R is false.
- (4) Both A and R are true and R is the correct explanation of A.

Official Ans. by NTA (4)

Sol. Both A and R are true and R is the correct explanation of A.

Due to mass difference in isotopes of hydrogen, these have different physical property.

78. Match List-I with List-II.

	List - I		List -II
A.	16g of $\text{CH}_4(\text{g})$	I.	Weighs 28 g
B.	1g of $\text{H}_2(\text{g})$	II.	60.2×10^{23} electrons
C.	1 mole of $\text{N}_2(\text{g})$	III.	Weighs 32g
D.	0.5 mol of $\text{SO}_2(\text{g})$	IV.	Occupies 11.4 L volume at STP

Choose the correct answer from the options given below:

- (1) A-I, B-III, C-II, D-IV
- (2) A-II, B-III, C-IV, D-I
- (3) A-II, B-IV, C-III, D-I
- (4) A-II, B-IV, C-I, D-III

Official Ans. by NTA (4)

Sol. 16g $\text{CH}_4 = 1$ mole CH_4 contains $10 \times 6.02 \times 10^{23}$ electrons

$$= 60.2 \times 10^{23}$$

1g $\text{H}_2 = 0.5$ mole H_2 gas occupy 11.35 litre volume at STP

$$1 \text{ mole of } \text{N}_2 = 28\text{g}$$

$$0.5 \text{ mole of } \text{SO}_2 = 32\text{g}$$

79. The correct order of metallic character is:

- (1) $\text{Be} > \text{Ca} > \text{K}$
- (2) $\text{Ca} > \text{K} > \text{Be}$
- (3) $\text{K} > \text{Ca} > \text{Be}$
- (4) $\text{K} > \text{Be} > \text{Ca}$

Official Ans. by NTA (3)

Sol. On moving from top to bottom metallic character increases while on moving from left to right metallic decreases.

$$\text{K} > \text{Ca} > \text{Be}.$$

80. Gibbs energy vs T plot for the formation of oxides is given below:

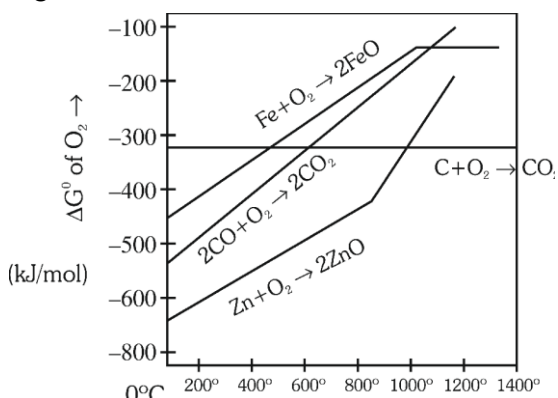

For the given diagram, the correct statement is-

- (1) At 600 °C, C can reduce ZnO
- (2) At 600 °C, C can reduce FeO
- (3) At 600 °C, CO cannot reduce FeO
- (4) At 600 °C, CO can reduce ZnO

Official Ans. by NTA (2)

Sol. at 600°C,

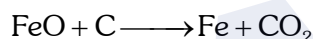

SECTION-B

81. $\text{A}(\text{g}) \rightleftharpoons 2\text{B}(\text{g}) + \text{C}(\text{g})$

For the given reaction, if the initial pressure is 450 mm Hg and the pressure at time t is 720 mm Hg at a constant temperature T and constant volume V. The fraction of A(g) decomposed under these conditions is $x \times 10^{-1}$. The value of x is _____ (nearest integer)

Official Ans. by NTA (3)

Sol. $\text{A}(\text{g}) \rightleftharpoons 2\text{B}(\text{g}) + \text{C}(\text{g})$

$$t = 0 \quad 450$$

$$\text{time } t \quad 450 - x \quad 2x \quad x$$

$$P_T = P_A + P_B + P_C$$

$$720 = 450 - x + 2x + x$$

$$2x = 270$$

$$x = 135$$

$$\text{Fraction of A decomposed} = \frac{135}{450} = 0.3 = 3 \times 10^{-1}$$

$$\text{So, } x = 3$$

82. In alkaline medium, the reduction of permanganate anion involves a gain of _____ electrons.

Official Ans. by NTA (3)

Sol. In faintly alkaline medium,

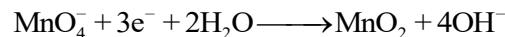

No. of electrons gained = 3

83. The number of endothermic process/es from the following is _____

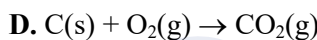
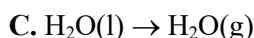
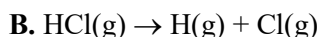
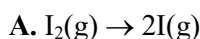

E. Dissolution of ammonium chloride in water

Official Ans. by NTA (4)

Sol. A → Endothermic (Atomisation)

B → Endothermic (Atomisation)

C → Endothermic (Vapourisation)

D → Exothermic (Combustion)

E → Endothermic (Dissolution)

84. The number of molecules from the following which contain only two lone pair of electrons is _____

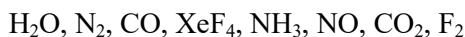

Official Ans. by NTA (4)

Sol. $\text{H}_2\text{O}, \text{CO}, \text{N}_2, \text{NO}$, has two lone pair of electrons.

85. The difference in the oxidation state of Xe between the oxidised product of Xe formed on complete hydrolysis of XeF_4 and XeF_4 is _____

Official Ans. by NTA (2)

Sol. $6\text{XeF}_4 + 12\text{H}_2\text{O} \longrightarrow 2\text{XeO}_3 + 4\text{Xe} + 24\text{HF} + 3\text{O}_2$

in XeO_3 , Oxidation state of Xe = +6

in XeF_4 , Oxidation state of Xe = +4

So difference in oxidation state = 2

86. An aqueous solution of volume 300 cm^3 contains 0.63 g of protein. The osmotic pressure of the solution at 300 K is 1.29 mbar . The molar mass of the protein is _____ g mol^{-1}

Given : $R = 0.083 \text{ L bar K}^{-1} \text{ mol}^{-1}$

Official Ans. by NTA (40535)

Sol. $\because \pi = CRT$

$$\pi = \frac{n}{V} RT$$

$$\pi = \frac{w}{V} \frac{RT}{M}$$

$$M = \frac{wRT}{\pi \times V}$$

$$M = \frac{0.63 \times 0.083 \times 300}{1.29 \times 10^{-3} \times 300 \times 10^{-3}}$$

$$M = 40535 \text{ gm/mol}$$

87. For a metal ion, the calculated magnetic moment is 4.90 BM . This metal ion has _____ number of unpaired electrons.

Official Ans. by NTA (4)

Sol. $\mu = \sqrt{n(n+2)} \text{ BM}$

$$4.90 = \sqrt{n(n+2)}$$

$$n = 4$$

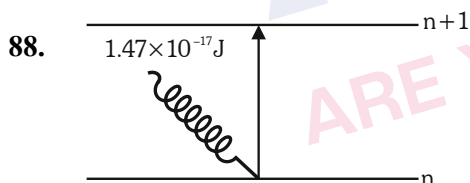

The electron in the n^{th} orbit of Li^{2+} is excited to $(n + 1)$ orbit using the radiation of energy $1.47 \times 10^{-17} \text{ J}$ (as shown in the diagram). The value of n is _____.

Given $R_H = 2.18 \times 10^{-18} \text{ J}$

Official Ans. by NTA (1)

Sol. $\Delta E = R_H Z^2 \left(\frac{1}{n_1^2} - \frac{1}{n_2^2} \right)$

$$1.47 \times 10^{-17} = 2.18 \times 10^{-18} \times 9 \left(\frac{1}{n^2} - \frac{1}{(n+1)^2} \right)$$

$$\frac{1.47}{1.96} = \frac{3}{4} = \frac{1}{n^2} - \frac{1}{(n+1)^2}$$

$$\text{So, } n = 1$$

89. The specific conductance of 0.0025 M acetic acid is $5 \times 10^{-5} \text{ S cm}^{-1}$ at a certain temperature. The dissociation constant of acetic acid is _____ $\times 10^{-7}$. (Nearest integer)

Consider limiting molar conductivity of CH_3COOH as $400 \text{ S cm}^2 \text{ mol}^{-1}$

Official Ans. by NTA (66)

Sol. $\wedge_m = \frac{k}{C} \times 1000$

Given $k = 5 \times 10^{-5} \text{ S cm}^{-1}$

$C = 0.0025 \text{ M}$

$$\wedge_m = \frac{5 \times 10^{-5} \times 1000}{0.0025} = \frac{5 \times 10^{-2}}{2.5 \times 10^{-3}}$$

$$= 20 \text{ S cm}^2 \text{ mol}^{-1}$$

$$\alpha = \frac{20}{400} = \frac{1}{20}$$

$$K_a = \frac{C\alpha^2}{1-\alpha} = \frac{0.0025 \times \frac{1}{20} \times \frac{1}{20}}{\frac{19}{20}}$$

$$= \frac{0.0025}{19 \times 20} = 6.6 \times 10^{-6}$$

$$= 66 \times 10^{-7}$$

90. The number of incorrect statement/s from the following is _____

- A. The successive half lives of zero order reactions decreases with time.
- B. A substance appearing as reactant in the chemical equation may not affect the rate of reaction
- C. Order and molecularity of a chemical reaction can be a fractional number
- D. The rate constant units of zero and second order reaction are $\text{mol L}^{-1} \text{ s}^{-1}$ and $\text{mol}^{-1} \text{ L s}^{-1}$ respectively

Official Ans. by NTA (1)

Sol. (A) For zero order $t_{1/2} = \frac{[A]_0}{2K}$ as concentration decreases half life decreases (Correct statement)
 (B) If order w.r.t. that reactant is zero then it will not affect rate of reaction. (Correct statement)
 (C) Order can be fractional but molecularity can not be (Incorrect statement)
 (D) For zero order reaction unit is $\text{mol L}^{-1} \text{ s}^{-1}$ and for second order reaction unit is $\text{mol}^{-1} \text{ L s}^{-1}$ (Correct statement)