

FINAL JEE-MAIN EXAMINATION – APRIL, 2023

(Held On Thursday 13th April, 2023)

TIME : 9 : 00 AM to 12 : 00 NOON

MATHEMATICS

TEST PAPER WITH SOLUTION

SECTION-A

1. $\int_0^{\infty} \frac{6}{e^{3x} + 6e^{2x} + 11e^x + 6} dx$

(1) $\log_e \left(\frac{512}{81} \right)$

(2) $\log_e \left(\frac{32}{27} \right)$

(3) $\log_e \left(\frac{256}{81} \right)$

(4) $\log_e \left(\frac{64}{27} \right)$

Official Ans. by NTA (2)

Sol.

$$\begin{aligned}
 I &= \int_0^{\infty} \frac{6}{(e^x + 1)(e^x + 2)(e^x + 3)} dx \\
 &= 6 \int_0^{\infty} \left(\frac{\frac{1}{2}}{e^x + 1} + \frac{-1}{e^x + 2} + \frac{\frac{1}{2}}{e^x + 3} \right) dx \\
 &= 3 \int_0^{\infty} \frac{e^{-x}}{1 + e^{-x}} dx - 6 \int_0^{\infty} \frac{e^{-x}}{1 + 2e^{-x}} dx + 3 \int_0^{\infty} \frac{e^{-x}}{1 + 3e^{-x}} dx \\
 &= 3 \left[-\ln(1 + e^{-x}) \right]_0^{\infty} + 6 \left[\ln(1 + 2e^{-x}) \right]_0^{\infty} \\
 &\quad - \frac{3}{2} \left[\ln(1 + 3e^{-x}) \right]_0^{\infty} \\
 &= 3 \ln 2 - 3 \ln 3 + \ln 4 \\
 &= 3 \ln \frac{2}{3} + \ln 4 \\
 &= \ln \frac{32}{27}
 \end{aligned}$$

2. $\max_{0 \leq x \leq \pi} \left\{ x - 2 \sin x \cos x + \frac{1}{3} \sin 3x \right\} =$

(1) $\frac{5\pi + 2 + 3\sqrt{3}}{6}$

(2) $\frac{\pi + 2 - 3\sqrt{3}}{6}$

(3) π

(4) 0

Official Ans. by NTA (1)

Sol.

$$f(x) = x - \sin 2x + \frac{1}{3} \sin 3x$$

$$f'(x) = 1 - 2 \cos 2x + \cos 3x = 0$$

$$x = \frac{5\pi}{6}, \frac{\pi}{6}$$

$$\therefore f''(x) = 4 \sin 2x - 3 \sin 3x$$

$$f''\left(\frac{5\pi}{6}\right) < 0$$

$$\Rightarrow \left(\frac{5\pi}{6}\right) \text{ is point of maxima}$$

$$f\left(\frac{5\pi}{6}\right) = \frac{5\pi}{6} + \frac{\sqrt{3}}{2} + \frac{1}{3}$$

3. The set of all $a \in \mathbb{R}$ for which the equation $x|x-1| + |x+2| + a = 0$ has exactly one real root is :

(1) $(-6, -3)$

(2) $(-\infty, \infty)$

(3) $(-6, \infty)$

(4) $(-\infty, -3)$

Official Ans. by NTA (2)

Sol.

$$f(x) = x|x-1| + |x+2|$$

$$x|x-1| + |x+2| + a = 0$$

$$x|x-1| + |x+2| = -a$$

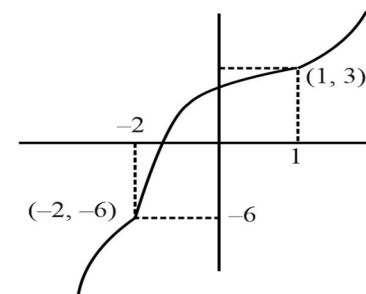

All values are increasing.

4. The negation of the statement $((A \wedge (B \vee C)) \Rightarrow (A \vee B)) \Rightarrow A$ is
- (1) equivalent to $\sim A$
 - (2) equivalent to $\sim C$
 - (3) equivalent to $B \vee \sim C$
 - (4) a fallacy
- Official Ans. by NTA (1)**

Sol.

$$p : ((A \wedge (B \vee C)) \Rightarrow (A \vee B)) \Rightarrow A$$

$$[\sim(A \wedge (B \vee C)) \vee (A \vee B)] \Rightarrow A$$

$$[(A \wedge (B \vee C)) \wedge \sim(A \vee B)] \vee A$$

$$(f \vee A) = A$$

$$\sim p \equiv \sim A$$

5. The distance of the point $(-1, 2, 3)$ from the plane $\vec{r} \cdot (\hat{i} - 2\hat{j} + 3\hat{k}) = 10$ parallel to the line of the shortest distance between the lines $\vec{r} = (\hat{i} - \hat{j}) + \lambda(2\hat{i} + \hat{k})$ and $\vec{r} = (2\hat{i} - \hat{j}) + \mu(\hat{i} - \hat{j} + \hat{k})$ is :
- (1) $3\sqrt{6}$
 - (2) $3\sqrt{5}$
 - (3) $2\sqrt{6}$
 - (4) $2\sqrt{5}$

Official Ans. by NTA (3)

Sol.

$$\text{Let } L_1 : \vec{r} = (\hat{i} - \hat{j}) + \lambda(2\hat{i} + \hat{k})$$

$$L_2 : \vec{r} = (2\hat{i} - \hat{j}) + \mu(\hat{i} - \hat{j} + \hat{k})$$

$$\vec{n} = \begin{vmatrix} \hat{i} & \hat{j} & \hat{k} \\ 2 & 0 & 1 \\ 1 & -1 & 1 \end{vmatrix}$$

$$\vec{n} = \hat{i} - \hat{j} - 2\hat{k}$$

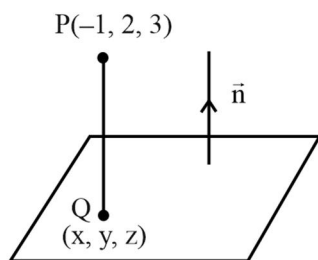

Equation of line along shortest distance of L_1 and L_2

$$\frac{x-1}{1} = \frac{y-2}{-1} = \frac{z-3}{-2} = r$$

$$\Rightarrow (x, y, z) \equiv (r-1, 2-r, 3-2r)$$

$$\Rightarrow (r-1) - 2(2-r) + 3(3-2r) = 10$$

$$\Rightarrow r = -2$$

$$\Rightarrow Q(x, y, z) \equiv (-3, 4, 7)$$

$$\Rightarrow PQ = \sqrt{4+4+16} = 2\sqrt{6}$$

6. A coin is biased so that the head is 3 times as likely to occur as tail. This coin is tossed until a head or three tails occur. If X denotes the number of tosses of the coin, then the mean of X is

(1) $\frac{21}{16}$

(2) $\frac{81}{64}$

(3) $\frac{15}{16}$

(4) $\frac{37}{16}$

Official Ans. by NTA (1)

Sol.

$$P(H) = \frac{3}{4}$$

$$P(T) = \frac{1}{4}$$

X	1	2	3
P(X)	$\frac{3}{4}$	$\frac{1}{4} \times \frac{3}{4}$	$\left(\frac{1}{4}\right)^3 + \left(\frac{1}{4}\right)^2 \times \frac{3}{4}$

$$\text{Mean } \bar{X} = \frac{3}{4} + \frac{3}{8} + 3\left(\frac{1}{64} + \frac{3}{64}\right)$$

$$= \frac{3}{4} + \frac{3}{8} + \frac{3}{16}$$

$$= 3\left(\frac{7}{16}\right)$$

$$= \frac{21}{16}$$

7. For the system of linear equations

$$2x + 4y + 2az = b$$

$$x + 2y + 3z = 4$$

$$2x - 5y + 2z = 8$$

which of the following is **NOT** correct ?

- (1) It has infinitely many solutions if $a = 3, b = 6$
- (2) It has unique solution if $a = b = 6$
- (3) It has unique solution if $a = b = 8$
- (4) It has infinitely many solution if $a = 3, b = 8$

Official Ans. by NTA (1)

Sol.

$$\Delta = \begin{vmatrix} 2 & 4 & 2a \\ 1 & 2 & 3 \\ 2 & -5 & 2 \end{vmatrix} = 18(3 - a)$$

$$\Delta_x = \begin{vmatrix} b & 4 & 2a \\ 4 & 2 & 3 \\ 8 & -5 & 2 \end{vmatrix} = (64 + 19b - 72a)$$

For unique solution $\Delta = 0$

$$\Rightarrow \boxed{a \neq 3} \text{ and } \boxed{b \in \mathbb{R}}$$

For Infinitely many solution ;

$$\Delta = \Delta_x = \Delta_y = \Delta_z = 0$$

$$\Rightarrow a = 3 \quad \therefore \Delta = 0$$

$$\text{and } b = 8 \quad \therefore \Delta_x = 0$$

8. For the differentiable function

$$f : \mathbb{R} - \{0\} \rightarrow \mathbb{R}, \text{ let } 3f(x) + 2f\left(\frac{1}{x}\right) = \frac{1}{x} - 10, \text{ then}$$

$$\left| f(3) + f'\left(\frac{1}{4}\right) \right| \text{ is equal to}$$

(1) 7

(2) $\frac{33}{5}$

(3) $\frac{29}{5}$

(4) 13

Official Ans. by NTA (4)

Sol.

$$\left[3f(x) + 2f\left(\frac{1}{x}\right) = \frac{1}{x} - 10 \right] \times 3$$

$$\left[2f(x) + 3f\left(\frac{1}{x}\right) = x - 10 \right] \times 2$$

$$5f(x) = \frac{3}{x} - 2x - 10$$

$$f(x) = \frac{1}{5} \left(\frac{3}{x} - 2x - 10 \right)$$

$$f'(x) = \frac{1}{5} \left(-\frac{3}{x^2} - 2 \right)$$

$$\left| f(3) + f'\left(\frac{1}{4}\right) \right| = \left| \frac{1}{5}(1 - 6 - 10) + \frac{1}{5}(-48 - 2) \right|$$

$$= |-3 - 10| = 13$$

9. Let the tangent and normal at the point $(3\sqrt{3}, 1)$

on the ellipse $\frac{x^2}{36} + \frac{y^2}{4} = 1$ meet the y-axis at the

points A and B respectively. Let the circle C be drawn taking AB as a diameter and the line $x = 2\sqrt{5}$ intersect C at the points P and Q. If the tangents at the points P and Q on the circle intersect at the point (α, β) , then $\alpha^2 - \beta^2$ is equal to

(1) $\frac{314}{5}$

(2) $\frac{304}{5}$

(3) 60

(4) 61

Official Ans. by NTA (2)

Sol.

Given ellipse $\frac{x^2}{36} + \frac{y^2}{4} = 1$

$$\frac{x}{4\sqrt{3}} + \frac{y}{4} = 1$$

$$y = 4$$

$$\frac{x}{4} - \frac{4}{4\sqrt{3}} = \frac{2}{\sqrt{3}}$$

$$y = -8$$

$$x^2 + y^2 + 4y - 32 = 0$$

$$hx + ky + 2(y + k) - 32 = 0$$

$$k = -2$$

$$hx + 2k - 32 = 0$$

$$hx = 36$$

$$\alpha = h = \frac{36}{2\sqrt{5}}$$

$$\beta = k = -2$$

$$\alpha^2 - \beta^2 = \frac{304}{5}$$

10. The area of the region enclosed by the curve $f(x) = \max\{\sin x, \cos x\}$, $-\pi \leq x \leq \pi$ and the x-axis is

- (1) $2(\sqrt{2} + 1)$
- (2) $2\sqrt{2}(\sqrt{2} + 1)$
- (3) $4(\sqrt{2})$
- (4) 4

Official Ans. by NTA (4)

Sol.

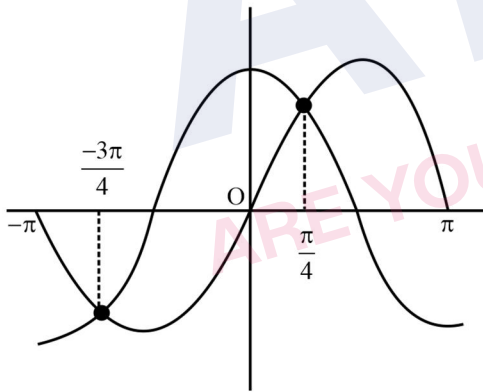

Area =

$$\left| \int_{-\pi}^{-3\pi/4} \sin x \, dx \right| + \left| \int_{-3\pi/4}^{\pi/4} \cos x \, dx \right| + \left| \int_{\pi/4}^{\pi} \cos x \, dx \right| + \left| \int_{\pi}^{\pi} \sin x \, dx \right|$$

$$= 4$$

11. The number of symmetric matrices of order 3, with all the entries from the set $\{0, 1, 2, 3, 4, 5, 6, 7, 8, 9\}$, is :

- (1) 6^{10}
- (2) 9^{10}
- (3) 10^9
- (4) 10^6

Official Ans. by NTA (4)

Sol.

$$A = \begin{bmatrix} a & b & c \\ b & d & e \\ c & e & f \end{bmatrix}, a, b, c, d, e, f \in \{0, 1, 2, \dots, 9\}$$

Number of matrices = 10^6

12. Among :

$$(S1) : \lim_{n \rightarrow \infty} \frac{1}{n^2} (2 + 4 + 6 + \dots + 2n) = 1$$

$$(S2) : \lim_{n \rightarrow \infty} \frac{1}{n^{16}} (1^{15} + 2^{15} + 3^{15} + \dots + n^{15}) = \frac{1}{16}$$

- (1) Both (S1) and (S2) are true
- (2) Both (S1) and (S2) are false
- (3) Only (S2) is true
- (4) Only (S1) is true

Official Ans. by NTA (1)

Sol.

$$S_1 : \lim_{n \rightarrow \infty} \frac{n(n+1)}{n^2} = 1 \Rightarrow \text{True}$$

$$S_2 : \lim_{n \rightarrow \infty} \frac{1}{n^{16}} \left(\sum r^{15} \right) = \lim_{n \rightarrow \infty} \frac{1}{n} \sum \left(\frac{r}{n} \right)^{15}$$

$$= \int_0^1 x^{15} \, dx = \frac{1}{16} \Rightarrow \text{True}$$

13. Let PQ be a focal chord of the parabola $y^2 = 36x$ of length 100, making an acute angle with the positive x-axis. Let the ordinate of P be positive and M be the point on the line segment PQ such that $PM:MQ=3:1$. Then which of the following points does NOT lie on the line passing through M and perpendicular to the line PQ?

- (1) $(-3, 43)$
- (2) $(-6, 45)$
- (3) $(3, 33)$
- (4) $(6, 29)$

Official Ans. by NTA (1)

Sol.

$$9 \left(t + \frac{1}{t} \right)^2 = 100$$

$$t = 3$$

$$\Rightarrow P(81, 54) \text{ \& } Q(1, -6)$$

$$M(21, 9)$$

$$\Rightarrow L \text{ is } (y-9) = \frac{-4}{3}(x-21)$$

$$3y - 27 = -4x + 84$$

$$4x + 3y = 111$$

For $x \in \mathbb{R}$, two real valued functions $f(x)$ and $g(x)$ are such that, $g(x) = \sqrt{x} + 1$ and $f \circ g(x) = x + 3 - \sqrt{x}$.

Then $f(0)$ is equal to

- (1) 1
- (2) -3
- (3) 5
- (4) 0

Official Ans. by NTA (3)

Sol.

$$g(x) = \sqrt{x} + 1$$

$$f \circ g(x) = x + 3 - \sqrt{x}$$

$$\begin{aligned} &= (\sqrt{x} + 1)^2 - 3(\sqrt{x} + 1) + 5 \\ &= g^2(x) - 3g(x) + 5 \\ \Rightarrow f(x) &= x^2 - 3x + 5 \\ \therefore f(0) &= 5 \end{aligned}$$

But, if we consider the domain of the composite function $f \circ g(x)$ then in that case $f(0)$ will be not defined as $g(x)$ cannot be equal to zero.

15. Fractional part of the number $\frac{4^{2022}}{15}$ is equal to

- (1) $\frac{4}{15}$
- (2) $\frac{1}{15}$
- (3) $\frac{14}{15}$
- (4) $\frac{8}{15}$

Official Ans. by NTA (2)

Sol.

$$\begin{aligned} \left\{ \frac{4^{2022}}{15} \right\} &= \left\{ \frac{2^{4044}}{15} \right\} \\ &= \left\{ \frac{(1+15)^{1011}}{15} \right\} \\ &= \frac{1}{15} \end{aligned}$$

16. Let $a = \hat{i} + 4\hat{j} + 2\hat{k}$, $b = 3\hat{i} - 2\hat{j} + 7\hat{k}$ and $c = 2\hat{i} - \hat{j} + 4\hat{k}$. If a vector \vec{d} satisfies $\vec{d} \times \vec{b} = \vec{c} \times \vec{b}$ and $\vec{d} \cdot \vec{a} = 24$, then $|\vec{d}|^2$ is equal to

- (1) 413
- (2) 423
- (3) 323
- (4) 313

Official Ans. by NTA (1)

Sol.:

$$\vec{d} \times \vec{b} = \vec{c} \times \vec{b}$$

$$\Rightarrow (\vec{d} - \vec{c}) \times \vec{b} = 0$$

$$\Rightarrow \vec{d} = \vec{c} + \lambda \vec{b}$$

$$\text{Also } \vec{d} \cdot \vec{a} = 24$$

$$\Rightarrow (\vec{c} + \lambda \vec{b}) \cdot \vec{a} = 24$$

$$\lambda = \frac{24 - \vec{a} \cdot \vec{c}}{\vec{b} \cdot \vec{a}} = \frac{24 - 6}{9} = 2$$

$$\Rightarrow \vec{d} = \vec{c} + 2(\vec{b})$$

$$= 8\hat{i} - 5\hat{j} + 18\hat{k}$$

$$\Rightarrow |\vec{d}|^2 = 64 + 25 + 324 = 413$$

17. Let $B = \begin{bmatrix} 1 & 3 & \alpha \\ 1 & 2 & 3 \\ \alpha & \alpha & 4 \end{bmatrix}$, $\alpha > 2$ be the adjoint of a

matrix A and $|A| = 2$, then $[\alpha \ -2\alpha \ \alpha]B \begin{bmatrix} \alpha \\ -2\alpha \\ \alpha \end{bmatrix}$ is

equal to :-

- (1) 16
- (2) 32
- (3) -16
- (4) 0

Official Ans. by NTA (3)

Sol.

$$\text{Given, } B = \begin{bmatrix} 1 & 3 & \alpha \\ 1 & 2 & 3 \\ \alpha & \alpha & 4 \end{bmatrix}$$

$$|B| = 4$$

$$1(8 - 3\alpha) - 3(4 - 3\alpha) + \alpha(\alpha - 2\alpha) = 4$$

$$-\alpha^2 + 6\alpha - 8 = 0$$

$$\alpha = 2, 4$$

$$\text{Given, } \alpha > 2$$

So, $\alpha = 2$ is rejected

$$[4 \ -8 \ 4] \begin{bmatrix} 1 & 3 & 4 \\ 1 & 2 & 3 \\ 4 & 4 & 4 \end{bmatrix} \begin{bmatrix} 4 \\ -8 \\ 4 \end{bmatrix} = [-16]_{1 \times 1}$$

18. Let $s_1, s_2, s_3, \dots, s_{10}$ respectively be the sum to 12 terms of 10 A.P.s whose first terms are $1, 2, 3, \dots, 10$ and the common differences are $1, 3, 5, \dots, 19$ respectively. Then $\sum_{i=1}^{10} s_i$ is equal to

- (1) 7380
- (2) 7220
- (3) 7360
- (4) 7260

Official Ans. by NTA (4)

Sol.

$$S_k = 6(2k + (11)(2k - 1))$$

$$S_k = 6(2k + 22k - 11)$$

$$S_k = 144k - 66$$

$$\begin{aligned} \sum_{k=1}^{10} S_k &= 144 \sum_{k=1}^{10} k - 66 \times 10 \\ &= 144 \times \frac{10 \times 11}{2} - 660 \\ &= 7920 - 660 \\ &= 7260 \end{aligned}$$

19. Let $y = y_1(x)$ and $y = y_2(x)$ be the solution curves of the differential equation $\frac{dy}{dx} = y + 7$ with initial conditions $y_1(0)=0, y_2(0)=1$ respectively. Then the curves $y = y_1(x)$ and $y = y_2(x)$ intersect at

- (1) Two points
- (2) no point
- (3) infinite number of points
- (4) one point

Official Ans. by NTA (2)

Sol.

$$\frac{dy}{dx} = y + 7 \Rightarrow \frac{dy}{y+7} = dx$$

$$\text{I.F.} = e^{-x}$$

$$ye^{-x} = \int 7e^{-x} dx$$

$$\Rightarrow ye^{-x} = -7e^{-x} + c$$

$$\Rightarrow y = -7 + ce^x$$

$$-7 + 7e^x = -7 + 8e^x$$

$$\Rightarrow e^x = 0$$

No solution

20. Let the equation of plane passing through the line of intersection of the planes $x + 2y + az = 2$ and $x - y + z = 3$ be $5x - 11y + bz = 6a - 1$. For $c \in \mathbb{Z}$, if the distance of this plane from the point

$(a, -c, c)$ is $\frac{2}{\sqrt{a}}$, then $\frac{a+b}{c}$ is equal to

- (1) -2
- (2) 2
- (3) -4
- (4) 4

Official Ans. by NTA (3)

Sol.

$$(x + 2y + az - 2) + \lambda(x - y + z - 3) = 0$$

$$\frac{1+\lambda}{5} = \frac{2-\lambda}{-11} = \frac{a+\lambda}{b} = \frac{2+3\lambda}{6a-1}$$

$$\lambda = -\frac{7}{2}, a = 3, b = 1$$

$$\frac{2}{\sqrt{a}} = \frac{|5a + 11c + bc - 6a + 1|}{\sqrt{25 + 121 + 1}}$$

$$c = -1$$

$$\therefore \frac{a+b}{c} = \frac{3+1}{-1} = -4$$

SECTION-B

21. Let α be the constant term in the binomial

expansion of $\left(\sqrt{x} - \frac{6}{x^2}\right)^n$, $n \leq 15$. If the sum of

the coefficients of the remaining terms in the expansion is 649 and the coefficient of x^{-n} is $\lambda\alpha$, then λ is equal to _____.

Official Ans. by NTA (36)

Sol.

$$T_{k+1} = {}^n C_k (x)^{\frac{n-k}{2}} (-6)^k (x)^{\frac{-3}{2}k}$$

$$\frac{n-k}{2} - \frac{3}{2}k = 0$$

$$n - 4k = 0$$

$$(-5)^n - \left({}^n C_{\frac{n}{4}} (-6)^{\frac{n}{4}} \right) = 649$$

By observation ($625 + 24 = 649$), we get $n = 4$

$$\therefore n = 4 \text{ \& } k = 1$$

Required is coefficient of x^{-4} is $\left(\sqrt{4} - \frac{6}{3} \right)^4$

$${}^4 C_1 (-6)^3$$

By calculating we will get $\lambda = 36$

22. If

$$S = \left\{ x \in \mathbb{R} : \sin^{-1} \left(\frac{x+1}{\sqrt{x^2+2x+2}} \right) - \sin^{-1} \left(\frac{x}{\sqrt{x^2+1}} \right) = \frac{\pi}{4} \right\},$$

then

$$\sum_{x \in \mathbb{R}} \left(\sin \left((x^2+x+5) \frac{\pi}{2} \right) - \cos \left((x^2+x+5) \pi \right) \right) \text{ is}$$

equal to _____.

Official Ans. by NTA (4)

Sol.

$$\sin^{-1} \left(\frac{(x+1)}{\sqrt{(x+1)^2+1}} \right) - \sin^{-1} \left(\frac{x}{\sqrt{x^2+1}} \right) = \frac{\pi}{4}$$

$$\therefore \frac{t}{\sqrt{t^2+1}} \in (-1, 1)$$

$$\sin^{-1} \left(\frac{(x+1)}{\sqrt{(x+1)^2+1}} \right) = \sin^{-1} \left(\frac{x}{\sqrt{x^2+1}} \right) + \frac{\pi}{4}$$

$$\begin{aligned} \frac{(x+1)}{\sqrt{(x+1)^2+1}} &= \left(\frac{1}{\sqrt{2}} \right) \cos \left(\sin^{-1} \left(\frac{x}{\sqrt{x^2+1}} \right) \right) + \frac{1}{\sqrt{2}} \left(\frac{x}{\sqrt{x^2+1}} \right) \\ &= \frac{1}{\sqrt{2}} \left(\frac{1}{\sqrt{x^2+1}} + \frac{x}{\sqrt{x^2+1}} \right) \end{aligned}$$

$$\frac{(x+1)}{\sqrt{(x+1)^2+1}} = \frac{1}{\sqrt{2}} \left(\frac{1+x}{\sqrt{x^2+1}} \right)$$

After solving this equation, we get

$$x = -1 \text{ or } x = 0$$

$$S = \{-1, 0\}$$

$$\sum_{x \in \mathbb{R}} \left(\sin \left((x^2+x+5) \frac{\pi}{2} \right) - \cos \left((x^2+x+5) \pi \right) \right)$$

$$\begin{aligned} &= \left[\sin \left(\frac{5\pi}{2} \right) - \cos(5\pi) \right] + \left[\sin \left(\frac{5\pi}{2} \right) - \cos(5\pi) \right] \\ &= 4 \end{aligned}$$

23. Let $\omega = z\bar{z} + k_1z + k_2iz + \lambda(1+i)$, $k_1, k_2 \in \mathbb{R}$. Let $\text{Re}(\omega) = 0$ be the circle C of radius 1 in the first quadrant touching the line $y=1$ and the y -axis. If the curve $\text{Im}(\omega) = 0$ intersects C at A and B , then $30(AB)^2$ is equal to _____.

Official Ans. by NTA (24)

Sol.

$$\omega = z\bar{z} + k_1z + k_2iz + \lambda(1+i)$$

$$\text{Re}(\omega) = x^2 + y^2 + k_1x - k_2y + \lambda = 0$$

$$\text{Centre} \equiv \left(\frac{-k_1}{2}, \frac{k_2}{2} \right) \equiv (1, 2)$$

$$\Rightarrow k_1 = -2, k_2 = 4$$

$$\text{radius} = 1 \Rightarrow \lambda = 4$$

$$\text{Im} = k_1y + k_2x + \lambda = 0$$

$$\therefore 2x - y + 2 = 0$$

$$d = \frac{2}{\sqrt{5}}$$

$$\frac{l^2}{4} = 1 - \frac{4}{5} = \frac{1}{5}$$

$$\therefore 30l^2 = 24$$

24. Let for $x \in \mathbb{R}, S_0(x) = x,$

$$S_k(x) = C_k x + k \int_0^x S_{k-1}(t) dt, \text{ where}$$

$$C_0 = 1, C_k = 1 - \int_0^1 S_{k-1}(x) dx, \quad k = 1, 2, 3, \dots \text{ Then}$$

$$S_2(3) + 6C_3 \text{ is equal to } \underline{\hspace{2cm}}.$$

Official Ans. by NTA (18)

Sol.

Given,

$$S_k(x) = C_k x + k \int_0^x S_{k-1}(t) dt,$$

Put $k = 2$ and $x = 3$

$$S_2(3) = C_2(3) + 2 \int_0^3 S_1(t) dt \quad \dots(1)$$

Also,

$$S_1(x) = C_1(x) + \int_0^x S_0(t) dt$$

$$= C_1 x + \frac{x^2}{2}$$

$$S_2(3) = 3C_2 + 2 \int_0^3 \left(C_1 t + \frac{t^2}{2} \right) dt$$

$$= 3C_2 + 9C_1 + 9$$

Also,

$$C_1 = 1 - \int_0^1 S_0(x) dx = \frac{1}{2}$$

$$C_2 = 1 - \int_0^1 S_1(x) dx = 0$$

$$\begin{aligned} C_3 &= 1 - \int_0^1 S_2(x) dx \\ &= 1 - \int_0^1 \left(C_2 x + C_1 x^2 + \frac{x^3}{3} \right) dx \\ &= \frac{3}{4} \end{aligned}$$

$$\begin{aligned} S_2(x) &= C_2 x + 2 \int_0^x S_1(t) dt \\ &= C_2 x + C_1 x^2 + \frac{x^3}{3} \end{aligned}$$

$$\Rightarrow S_2(3) + 6C_3 = 6C_3 + 3C_2 + 9C_1 + 9 = 18$$

25. The sum to 20 terms of the series

$$2.2^2 - 3^2 + 2.4^2 - 5^2 + 2.6^2 - \dots \text{ is equal to } \underline{\hspace{2cm}}.$$

Official Ans. by NTA (1310)

Sol.

$$(2^2 - 3^2 + 4^2 - 5^2 + 20 \text{ terms}) +$$

$$(2^2 + 4^2 + \dots + 10 \text{ terms})$$

$$-(2 + 3 + 4 + 5 + \dots + 11) + 4[1 + 2^2 + \dots + 10^2]$$

$$-\left[\frac{21 \times 22}{2} - 1 \right] + 4 \times \frac{10 \times 11 \times 21}{6}$$

$$= 1 - 231 + 14 \times 11 \times 10$$

$$= 1540 + 1 - 231$$

$$= 1310$$

26. The number of seven digit positive integers formed using the digits 1,2,3 and 4 only and sum of the digits equal to 12 is _____.

Official Ans. by NTA (413)

Sol.

$$x_1 + x_2 + x_3 + x_4 + x_5 + x_6 + x_7 = 12, \quad x_i \in \{1, 2, 3, 4\}$$

$$\text{No. of solutions} = {}^{5+7-1}C_{7-1} - \frac{7!}{6!} - \frac{7!}{5!} = 413$$

27. Let m_1 and m_2 be the slopes of the tangents drawn from the point $P(4,1)$ to the hyperbola

$$H: \frac{y^2}{25} - \frac{x^2}{16} = 1. \text{ If } Q \text{ is the point from which the}$$

tangents drawn to H have slopes $|m_1|$ and $|m_2|$ and they make positive intercepts α and β on the x-

$$\text{axis, then } \frac{(PQ)^2}{\alpha\beta} \text{ is equal to } \underline{\hspace{2cm}}.$$

Official Ans. by NTA (8)

Sol.

Equation of tangent to the hyperbola $\frac{y^2}{a^2} - \frac{x^2}{b^2} = 1$

$$y = mx \pm \sqrt{a^2 - b^2m^2}$$

passing through (4, 1)

$$1 = 4m \pm \sqrt{25 - 16m^2} \Rightarrow 4m^2 - m - 3 = 0$$

$$\Rightarrow m = 1, \frac{-3}{4}$$

Equation of tangent with positive slopes 1 & $\frac{3}{4}$.

$$\left. \begin{aligned} 4y &= 3x - 16 \\ y &= x - 3 \end{aligned} \right\} \text{with positive intercept on x-axis.}$$

$$\alpha = \frac{16}{3}, \beta = 3$$

Intersection points:

$$Q : (-4, -7)$$

$$P : (4, 1)$$

$$PQ^2 = 128$$

$$\frac{PQ^2}{\alpha\beta} = \frac{128}{16} = 8$$

28. Let the image of the point $\left(\frac{5}{3}, \frac{5}{3}, \frac{8}{3}\right)$ in the plane $x - 2y + z - 2 = 0$ be P. If the distance of the point $Q(6, -2, \alpha), \alpha > 0$, from P is 13, then α is equal to _____.

Official Ans. by NTA (15)

Sol.

Image of point $\left(\frac{5}{3}, \frac{5}{3}, \frac{8}{3}\right)$

$$\frac{x - \frac{5}{3}}{1} = \frac{y - \frac{5}{3}}{-2} = \frac{z - \frac{8}{3}}{1} = \frac{-2\left(1 \times \frac{5}{3} + (-2) \times \frac{8}{3} + 1 \times \frac{8}{3} - 2\right)}{1^2 + 2^2 + 1^2} = \frac{1}{3}$$

$$\therefore x = 2, y = 1, z = 3$$

$$13^2 = (6 - 2)^2 + (-2 - 1)^2 + (\alpha - 3)^2$$

$$\Rightarrow (\alpha - 3)^2 = 144 \Rightarrow \alpha = 15 (\because \alpha > 0)$$

29. Let $a = 3\hat{i} + \hat{j} - \hat{k}$ and $c = 2\hat{i} - 3\hat{j} + 3\hat{k}$. If b is a vector such that $\vec{a} = \vec{b} \times \vec{c}$ and $|\vec{b}|^2 = 50$, then $|72 - |\vec{b} + \vec{c}|^2|$ is equal to _____.

Official Ans. by NTA (66)

Sol.

$$|\vec{a}| = \sqrt{11}, |\vec{c}| = \sqrt{22}$$

$$|\vec{a}| = |\vec{b} \times \vec{c}| = |\vec{b}||\vec{c}|\sin\theta$$

$$\sqrt{11} = \sqrt{50}\sqrt{22}\sin\theta$$

$$\Rightarrow \sin\theta = \frac{1}{10}$$

$$|\vec{b} + \vec{c}|^2 = |\vec{b}|^2 + |\vec{c}|^2 + 2\vec{b} \cdot \vec{c}$$

$$= |\vec{b}|^2 + |\vec{c}|^2 + 2|\vec{b}||\vec{c}|\cos\theta$$

$$= 50 + 22 + 2 \times \sqrt{50} \times \sqrt{22} \times \frac{\sqrt{99}}{10}$$

$$= 72 + 66$$

$$|72 - |\vec{b} + \vec{c}|^2| = 66$$

30. Let the mean of the data

x	1	3	5	7	9
Frequency(f)	4	24	28	α	8

be 5. If m and σ^2 are respectively the mean deviation about the mean and the variance of the data, then $\frac{3\alpha}{m + \sigma^2}$ is equal to _____.

Official Ans. by NTA (8)

Sol.

$$5 = \bar{x} = \frac{\sum x_i f_i}{\sum f_i} = \frac{4 + 72 + 140 + 7\alpha + 72}{64 + \alpha}$$

$$\Rightarrow 320 + 5\alpha = 288 + 7\alpha \Rightarrow 2\alpha = 32 \Rightarrow \alpha = 16$$

$$\text{M.D.}(\bar{x}) = \frac{\sum f_i |x_i - \bar{x}|}{\sum f_i} \text{ where } \sum f_i = 64 + 16 = 80$$

$$\text{M.D.}(\bar{x}) = \frac{4 \times 4 + 24 \times 2 + 28 \times 0 + 16 \times 2 + 8 \times 4}{80}$$

$$= \frac{8}{5}$$

$$\text{Variance} = \frac{\sum f_i (x_i - \bar{x})^2}{\sum f_i}$$

$$= \frac{4 \times 16 + 24 \times 4 + 0 + 16 \times 4 + 8 \times 16}{80} = \frac{352}{80}$$

$$\therefore \frac{3\alpha}{m + \sigma^2} = \frac{3 \times 16}{\frac{128}{80} + \frac{352}{80}} = 8$$

PHYSICS

TEST PAPER WITH SOLUTION

SECTION-A

31. Which of the following Maxwell's equations is valid for time varying conditions but not valid for static conditions :

- (1) $\oint \vec{B} \cdot d\vec{l} = \mu_0 I$ (2) $\oint \vec{E} \cdot d\vec{l} = 0$
 (3) $\oint \vec{E} \cdot d\vec{l} = -\frac{\partial \phi_B}{\partial t}$ (4) $\oint \vec{D} \cdot d\vec{A} = Q$

Official Ans. by NTA (3)

Sol. Based on equations of Maxwell

32. Different combination of 3 resistors of equal resistance R are shown in the figures. The increasing order for power dissipation is:

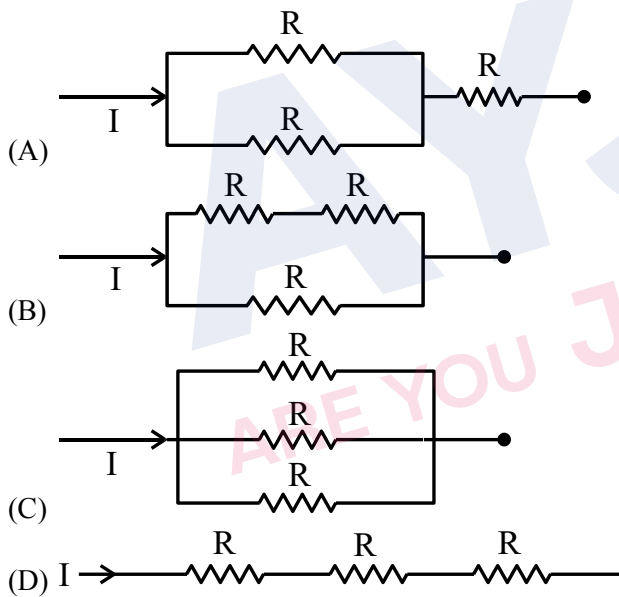

- (1) $P_A < P_B < P_C < P_D$
 (2) $P_C < P_D < P_A < P_B$
 (3) $P_B < P_C < P_D < P_A$
 (4) $P_C < P_B < P_A < P_D$

Official Ans. by NTA (4)

Sol. $P = I^2 R$

$$R_1 = \frac{3R}{2}, R_2 = \frac{2R}{3}, R_3 = \frac{R}{3}, R_4 = 3R$$

Since i is same, hence $P \propto R$ so options (4) is correct

33. A vessel of depth 'd' is half filled with oil of refractive index n_1 and the other half is filled with water of refractive index n_2 . The apparent depth of this vessel when viewed from above will be-

- (1) $\frac{d n_1 n_2}{(n_1 + n_2)}$
 (2) $\frac{d(n_1 + n_2)}{2n_1 n_2}$
 (3) $\frac{d n_1 n_2}{2(n_1 + n_2)}$
 (4) $\frac{2d(n_1 + n_2)}{n_1 n_2}$

Official Ans. by NTA (2)

Sol. Formula used $d_{app} = \frac{d_1}{n_1} + \frac{d_2}{n_2}$

$$d_{app} = \frac{d}{2} \left[\frac{n_1 + n_2}{n_1 n_2} \right]$$

34. The source of time varying magnetic field may be
 (A) a permanent magnet
 (B) an electric field changing linearly with time
 (C) direct current
 (D) a decelerating charge particle
 (E) an antenna fed with a digital signal
 Choose the correct answer from the options given below:

- (1) (D) only
 (2) (C) and (E) only
 (3) (A) only
 (4) (B) and (D) only

Official Ans. by NTA (1)

Sol. Source of time varying magnetic field may be

→ accelerated or retarded charge which produces varying electric and magnetic fields.

→ An electric field varying linearly with time will not produce variable magnetic field as current will be constant



35. Two trains 'A' and 'B' of length ' l ' and ' $4l$ ' are travelling into a tunnel of length ' L ' in parallel tracks from opposite directions with velocities 108 km/h and 72 km/h, respectively. If train 'A' takes 35s less time than train 'B' to cross the tunnel then, length ' L ' of tunnel is :

(Given $L = 60l$)

- (1) 1200 m
- (2) 2700 m
- (3) 1800 m
- (4) 900 m

Official Ans. by NTA (3)

Sol. $\frac{60l + 4l}{20} - \frac{61l}{30} = 35$
 $\Rightarrow l = \frac{1050}{35}$

$\Rightarrow L = 60l = \frac{1050}{35} \times 60 = 1800 \text{ m}$

36. The ratio of powers of two motors is $\frac{3\sqrt{x}}{\sqrt{x+1}}$, that are capable of raising 300 kg water in 5 minutes and 50 kg water in 2 minutes respectively from a well of 100 m deep. The value of x will be

- (1) 2
- (2) 4
- (3) 2.4
- (4) 16

Official Ans. by NTA (4)

Sol. Average Power = $\frac{\text{total work done}}{\text{total time}}$

So $P = \frac{mgh}{t}$

$\frac{P_1}{P_2} = \frac{\frac{m_1gh}{t_1}}{\frac{m_2gh}{t_2}} = \frac{m_1}{m_2} \cdot \frac{t_2}{t_1}$

$\frac{P_1}{P_2} = \frac{300 \times 2}{5 \times 50} = \frac{12}{5} = \frac{3\sqrt{x}}{\sqrt{x+1}}$

$12\sqrt{x+1} = 15\sqrt{x}$

$3\sqrt{x} = 12$

$x = 16$

37. A planet having mass $9M_e$ and radius $4R_e$, where M_e and R_e are mass and radius of earth respectively, has escape velocity in km/s given by:

(Given escape velocity on earth

$V_e = 11.2 \times 10^3 \text{ m/s}$)

- (1) 67.2
- (2) 16.8
- (3) 33.6
- (4) 11.2

Official Ans. by NTA (2)

Sol. $V_p = \sqrt{\frac{2GM_p}{R_p}}$ $V_E = \sqrt{\frac{2GM_E}{R_E}}$

$\frac{V_p}{V_E} = \frac{\sqrt{\frac{2GM_p}{R_p}}}{\sqrt{\frac{2GM_E}{R_E}}} = \sqrt{\frac{R_E}{R_p} \times \frac{M_p}{M_E}}$

$V_p = \sqrt{\frac{1}{4} \times 9} \times V_E = \frac{3}{2} V_E$

$V_p = \frac{3}{2} \times 11.2 \text{ km/sec}$

$= 16.8 \text{ km/sec}$

38. The difference between threshold wavelengths for two metal surfaces A and B having work function $\phi_A = 9\text{eV}$ and $\phi_B = 4.5\text{eV}$ in nm is:

(Given, $hc = 1242 \text{ eV nm}$)

- (1) 264
- (2) 138
- (3) 276
- (4) 540

Official Ans. by NTA (2)

Sol. $\lambda_A = \left(\frac{1242}{9}\right) = 138 \text{ nm}$

$\lambda_B = \left(\frac{1242}{4.5}\right) = 276 \text{ nm}$

$\lambda_B - \lambda_A = 138 \text{ nm}$

39. A bullet 10 g leaves the barrel of gun with a velocity of 600 m/s. If the barrel of gun is 50 cm long and mass of gun is 3 kg, then value of impulse supplied to the gun will be :

- (1) 12 Ns (2) 6 Ns
(3) 36 Ns (4) 3 Ns

Official Ans. by NTA (2)

Sol. By momentum conservation

$$0 = 3(-v) + 0.01(600 - v)$$

$$v \approx 2 \text{ m/s}$$

$$\text{Impulse on gun} = 3 \times 2 = 6 \text{ Ns}$$

40. Two charges each of magnitude 0.01 C and separated by a distance of 0.4 mm constitute an electric dipole. If the dipole is placed in an uniform electric field 'E' of 10 dyne/C making 30° angle with E, the magnitude of torque acting on dipole is :

- (1) $4.0 \times 10^{-10} \text{ Nm}$ (2) $2.0 \times 10^{-10} \text{ Nm}$
(3) $1.0 \times 10^{-8} \text{ Nm}$ (4) $1.5 \times 10^{-9} \text{ Nm}$

Official Ans. by NTA (2)

Sol. $|\vec{P}| = qd$

$$= 0.01 \times 0.4 \times 10^{-3}$$

$$= 4 \times 10^{-6}$$

$$|\vec{\tau}| = PE \sin \theta$$

$$= 4 \times 10^{-6} \times 10 \times 10^{-5} \times \sin 30$$

$$= 4 \times 10^{-6-5+1} \times \frac{1}{2}$$

$$= 2 \times 10^{-10}$$

41. A disc is rolling without slipping on a surface. The radius of the disc is R. At t = 0, the top most point on the disc is A as shown in figure. When the disc completes half of its rotation, the displacement of point A from its initial position is

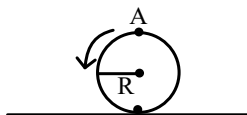

- (1) $R\sqrt{\pi^2 + 4}$ (2) $R\sqrt{\pi^2 + 1}$
(3) 2R (4) $2R\sqrt{1 + 4\pi^2}$

Official Ans. by NTA (1)

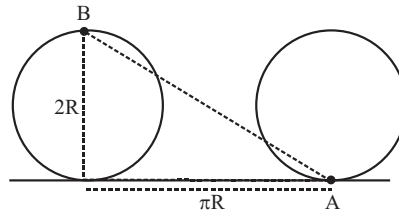

Sol.

$$\text{Displacement} = \sqrt{(2R)^2 + (\pi R)^2} = R\sqrt{4 + \pi^2}$$

42. Match List - I with List - II

List - I (Layer of atmosphere)	List - II (Approximate height over earth's surface)
(A) F ₁ - Layer	(I) 10 km
(B) D - Layer	(II) 170 - 190 km
(C) Troposphere	(III) 100 km
(D) E-layer	(IV) 65 - 75 km

Choose the correct answer from the options given below:

- (1) A - III, B - IV, C - I, D - II
(2) A - II, B - IV, C - III, D - I
(3) A - II, B - I, C - IV, D - III
(4) A - II, B - IV, C - I, D - III

Official Ans. by NTA (4)

Sol. Based on Theory

43. The rms speed of oxygen molecule in a vessel at particular temperature is $\left(1 + \frac{5}{x}\right)^{\frac{1}{2}} v$, where v is the average speed of the molecule. The value of x will be: (Take $\pi = \frac{22}{7}$)

- (1) 28
(2) 27
(3) 8
(4) 4

Official Ans. by NTA (1)

Sol. $\sqrt{\frac{3RT}{M}} = \left(1 + \frac{5}{x}\right)^{\frac{1}{2}} \sqrt{\frac{8RT}{\pi M}}$
 $\Rightarrow \frac{3 \times 22}{7 \times 8} = 1 + \frac{5}{x}$
 $\Rightarrow x = 28$

44. A body of mass (5 ± 0.5) kg is moving with a velocity of (20 ± 0.4) m/s. Its kinetic energy will be
- (1) (1000 ± 140) J
 - (2) (1000 ± 0.14) J
 - (3) (500 ± 0.14) J
 - (4) (500 ± 140) J

Official Ans. by NTA (1)

Sol. $k = \frac{1}{2}mv^2$

$$k = \frac{1}{2} \times 5 \times 400 = 5 \times 200 = 1000 \text{ J}$$

$$\frac{\Delta k}{2k} = \frac{\Delta m}{m} + \frac{2 \Delta v}{v} = \frac{0.5}{5} + \frac{2 \times 0.4}{20}$$

$$\Delta k = 1000 \left(\frac{1}{10} + \frac{4}{100} \right) = 1000 \left(\frac{10+4}{100} \right) = 140 \text{ J}$$

45. Two bodies are having kinetic energies in the ratio 16 : 9. If they have same linear momentum, the ratio of their masses respectively is :
- (1) 4 : 3
 - (2) 3 : 4
 - (3) 16 : 9
 - (4) 9 : 16

Official Ans. by NTA (4)

Sol. $\frac{K_1}{K_2} = \frac{p_1^2}{2m_1} \times \frac{2m_2}{p_2^2} = \frac{m_2}{m_1} = \frac{16}{9}$

$$\frac{m_1}{m_2} = \frac{9}{16}$$

46.

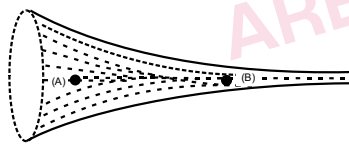

The figure shows a liquid of given density flowing steadily in horizontal tube of varying cross-section. Cross sectional areas at A is 1.5 cm^2 , and B is 25 mm^2 , if the speed of liquid at B is 60 cm/s then $(P_A - P_B)$ is :

(Given P_A and P_B are liquid pressures at A and B points.

Density $\rho = 1000 \text{ kg m}^{-3}$

A and B are on the axis of tube

- (1) 175 Pa
- (2) 27 Pa
- (3) 135 Pa
- (4) 36 Pa

Official Ans. by NTA (1)

Sol. From continuity theorem $A_1V_1 = A_2V_2$

$$1.5 \times V_1 = 25 \times 10^{-2} \times 60$$

$$V_1 = \frac{25 \times 60 \times 10^{-2} \times 10}{1.5}$$

$$V_1 = 10 \text{ cm / s}$$

By Bernoulli's theorem

$$P_1 + \frac{1}{2} \times 1000 \times (0.1)^2 = P_2 + \frac{1}{2} \times 1000 \times (0.6)^2$$

$$P_1 + 5 = P_2 + \frac{1}{2} \times 1000 \times 36 \times 10^{-2}$$

$$P_1 + 5 = P_2 + 180$$

$$P_1 - P_2 = 175 \text{ Pa}$$

47. Under isothermal condition, the pressure of a gas is given by $P = aV^{-3}$, where a is a constant and V is the volume of the gas. The bulk modulus at constant temperature is equal to

(1) $\frac{P}{2}$ (2) 3 P

(3) 2 P (4) P

Official Ans. by NTA (2)

Sol. $B = -\frac{dP}{dv/v}$

$$Pv^3 = a$$

Differentiating w.r.t to pressure

$$v^3 + P3v^2 \frac{dv}{dP} = 0$$

$$v = -3 \frac{Pdv}{dP} = 0$$

$$v = -3 \frac{Pdv}{dP}$$

$$\frac{dP \cdot v}{dv} = -3P$$

$$B = -\left(\frac{dPv}{dv} \right) = -(-3P) = 3P$$

48. For the following circuit and given inputs A and B, choose the correct option for output 'Y'

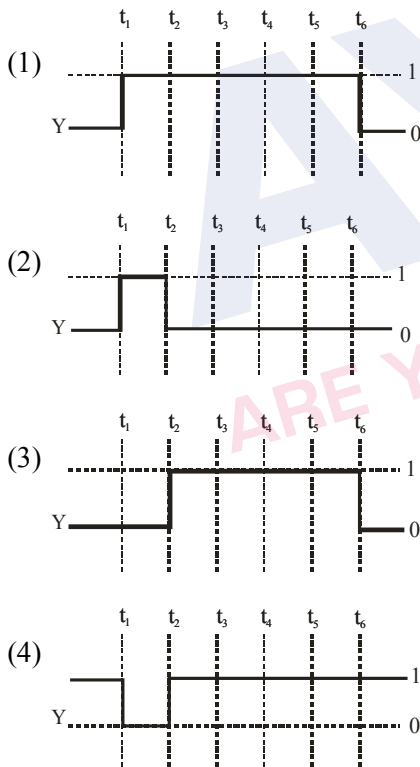
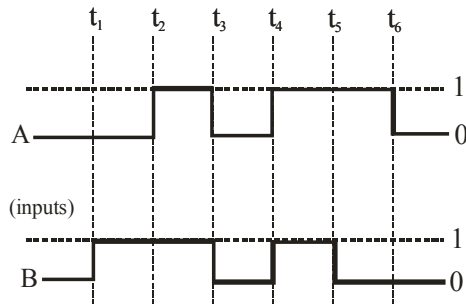
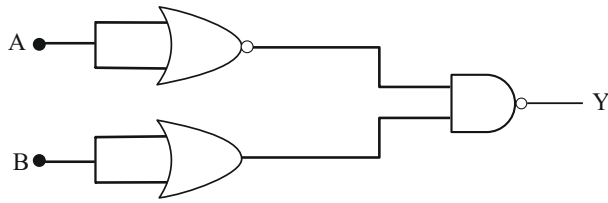

Official Ans. by NTA (4)

Sol. $Y = \overline{\overline{A} \cdot \overline{B}} = A + B$

49. Which graph represents the difference between total energy and potential energy of a particle executing SHM Vs its distance from mean position?

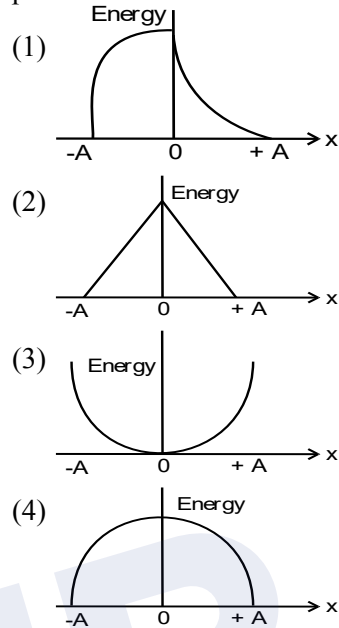

Official Ans. by NTA (4)

Sol. T.E. - P.E. = K.E.

$$K.E. = \frac{1}{2} m\omega^2 (A^2 - x^2)$$

Which is the equation of downward parabola.

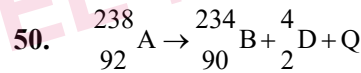

In the given nuclear reaction, the approximate amount of energy released will be :

[Given, mass of ${}_{92}^{238}\text{A} = 238.05079 \times 931.5 \text{ MeV} / c^2$,

mass of ${}_{90}^{234}\text{B} = 234.04363 \times 931.5 \text{ MeV} / c^2$,

mass of ${}_2^4\text{D} = 4.00260 \times 931.5 \text{ MeV} / c^2$]

- (1) 3.82 MeV
- (2) 5.9 MeV
- (3) 2.12 MeV
- (4) 4.25 MeV

Official Ans. by NTA (4)

Sol. $Q = (m_A - m_B - m_D) \times 931.5 \text{ MeV}$

$$= (238.05079 - 234.04363 - 4.00260) \times 931.5$$

$$\Rightarrow 4.25 \text{ MeV}$$

Section - B

51. The elastic potential energy stored in a steel wire of length 20 m stretched through 2 cm is 80 J. The cross sectional area of the wire is _____ mm^2 .

(Given, $y = 2.0 \times 10^{11} \text{Nm}^{-2}$)

Official Ans. by NTA (40)

Sol. Energy per unit volume = $\frac{1}{2} \text{stress} \times \text{strain}$

$$\text{Energy} = \frac{1}{2} \text{stress} \times \text{strain} \times \text{volume}$$

$$80 = \frac{1}{2} \times Y \times \text{strain}^2 \times A \times \ell$$

$$80 = \frac{1}{2} \times 2 \times 10^{11} \times \frac{(2 \times 10^{-2})^2}{400} \times A \times 20$$

$$20 = \frac{10^7}{20} \times A$$

$$40 \times 10^{-6} \text{ m}^2 = A$$

$$A = 40 \text{ mm}^2$$

52. A potential V_0 is applied across a uniform wire of resistance R . The power dissipation is P_1 . The wire is then cut into two equal halves and a potential of V_0 is applied across the length of each half. The total power dissipation across two wires is P_2 . The ratio $P_2 : P_1$ is $\sqrt{x} : 1$. The value of x is _____.

Official Ans. by NTA (16)

Sol. $P = VI = I^2 R = \frac{V^2}{R}$

Now $R = \frac{\rho l}{A}$

If wire is cut in two equal half

$$R' = \frac{R}{2}$$

$$\text{Initial } P_1 = \frac{V_0^2}{R}$$

$$\text{After } P_2 = \frac{V_0^2}{R'} \times 2 \Rightarrow \frac{V_0^2}{R} \times 4$$

$$\frac{P_2}{P_1} = 4 = \frac{\sqrt{x}}{1}$$

$$x = 16$$

53. At a given point of time the value of displacement of a simple harmonic oscillator is given as

$y = A \cos(30^\circ)$. If amplitude is 40 cm and kinetic energy at that time is 200 J, the value of force constant is $1.0 \times 10^x \text{Nm}^{-1}$. The value of x is _____.

Official Ans. by NTA (4)

Sol. General equation for displacement is given by

$$x = A \sin(\omega t + \phi)$$

at given time

$$\Rightarrow \omega t + \phi = 30^\circ$$

$$\Rightarrow x = 40 \times \frac{\sqrt{3}}{2} \Rightarrow 20\sqrt{3} \text{ cm}$$

$$\Rightarrow A = 40 \text{ cm}$$

$$\Rightarrow K.E = \frac{1}{2} k (A^2 - x^2) = 200$$

$$200 = \frac{1}{2} k \left(\frac{1600 - 1200}{100 \times 100} \right)$$

$$400 \times 100 \times 100 = k \times 400$$

$$k = 10^4$$

$$x = 4$$

54. When a resistance of 5Ω is shunted with a moving coil galvanometer, it shows a full scale deflection for a current of 250 mA, however when 1050Ω resistance is connected with it in series, it gives full scale deflection for 25 volt. The resistance of galvanometer is _____ Ω .

Official Ans. by NTA (50)

Sol.

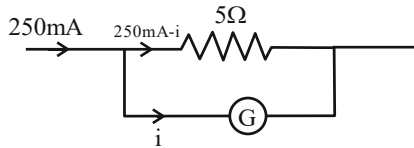

$$\frac{250 \text{ mA} \times 5}{5 + R_G} = i \quad \dots\dots (i)$$

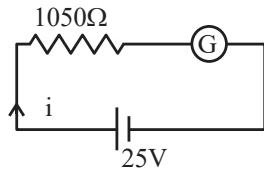

$$i = \frac{25}{1050 + R_G} \quad \dots\dots (ii)$$

From (i) and (ii)

$$\frac{25}{1050 + R_G} = \frac{5}{4(5 + R_G)}$$

$$100(5 + R_G) = 1050 \times 5 + R_G \times 5$$

$$95 R_G = 4750$$

$$R_G = 50 \Omega$$

55. The radius of 2nd orbit of He⁺ of Bohr's model is r₁ and that of fourth orbit of Be³⁺ is represented as r₂.

Now the ratio $\frac{r_2}{r_1}$ is x : 1. The value of x is

Official Ans. by NTA (2)

Sol. $r \propto \frac{n^2}{z}$

$$\frac{r_{\text{He}^+}}{r_{\text{Be}^{3+}}} = \frac{2^2 \times 4}{2 \times 4 \times 4} = \frac{1}{2}$$

56. A thin infinite sheet charge and an infinite line charge of respective charge densities +σ and +λ are placed parallel at 5 m distance from each other. Points 'P' and 'Q' are at $\frac{3}{\pi}$ m and $\frac{4}{\pi}$ m perpendicular distance from line charge towards sheet charge, respectively. 'E_P' and 'E_Q' are the magnitudes of resultant electric field intensities at point 'P' and 'Q', respectively. If $\frac{E_P}{E_Q} = \frac{4}{a}$ for

$2|\sigma| = |\lambda|$. Then the value of a is _____.

Official Ans. by NTA (6)

Sol. $E_A = \frac{\lambda}{2\pi\epsilon_0 r_A} - \frac{\sigma}{2\epsilon_0} \left\{ r_A = \frac{3}{\pi} \right\}$
 $= \frac{1}{2\epsilon_0} \left[\frac{\lambda}{3} - \sigma \right]$
 $E_B = \frac{\lambda}{2\pi\epsilon_0 r_B} - \frac{\sigma}{2\epsilon_0} \left\{ r_B = \frac{4}{\pi} \right\}$
 $= \frac{1}{2\epsilon_0} \left[\frac{\lambda}{4} - \sigma \right]$
 $\frac{E_A}{E_B} = \frac{4(\lambda - 3\sigma)}{3(\lambda - 4\sigma)}$
 $= \frac{4}{3} \left[\frac{2\sigma - 3\sigma}{2\sigma - 4\sigma} \right]$
 $= \frac{4}{3} \left[\frac{-\sigma}{-2\sigma} \right]$
 $= \frac{4}{6}$

57. In the given figure, an inductor and a resistor are connected in series with a battery of emf E volt. $\frac{E^a}{2b}$ J/s represents the maximum rate at which the energy is stored in the magnetic field (inductor).

The numerical value of $\frac{b}{a}$ will be _____

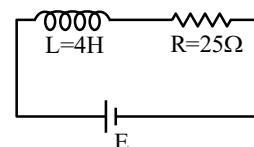

Official Ans. by NTA (25)



Sol. $E = \frac{1}{2} LI^2$

Rate of energy storing = $\frac{dE}{dt} = LI \frac{dI}{dt}$

Now we know for R-L circuit

$$I = \frac{E}{R} \left(1 - e^{-\frac{t}{L}} \right)$$

So $\frac{dI}{dt} = \frac{E}{L} e^{-\frac{t}{L}}$

$$\frac{dE}{dt} = \frac{E^2}{R} \left(1 - e^{-\frac{t}{L}} \right) \left(e^{-\frac{t}{L}} \right)$$

Time at which rate of power storing will be max,

$$t = \frac{L}{R \ln 2}$$

So $\frac{dE}{dt} = \frac{E^2}{R} \left(1 - \frac{1}{2} \right) \times \frac{1}{2}$

$$\Rightarrow \frac{E^2}{4R} = \frac{E^2}{100} = \frac{E^2}{2 \times 50}$$

$a = 2, b = 50$

So $\frac{b}{a} = 25$

58. A fish rising vertically upward with a uniform velocity of 8 ms^{-1} , observes that a bird is diving vertically downward towards the fish with the velocity of 12 ms^{-1} . If the refractive index of water is $\frac{4}{3}$, then the actual velocity of the diving bird to pick the fish, will be _____ ms^{-1} .

Official Ans. by NTA (3)

Sol. $\frac{V_{b/f}}{\frac{4}{3}} = \frac{-8}{4} + \frac{(-v)}{1}$

$$\Rightarrow \frac{-12}{4} = \frac{-8}{4} + \frac{(-v)}{1}$$

$\Rightarrow v = 3 \text{ m/s}$

59. A solid sphere is rolling on a horizontal plane without slipping. If the ratio of angular momentum about axis of rotation of the sphere to the total energy of moving sphere is $\pi : 22$ then, the value of its angular speed will be _____ rad/s.

Official Ans. by NTA (4)

Sol. $L = (I_{\text{com}})(\omega)$ and $K = \frac{1}{2}(I_{\text{com}})(\omega^2) + \frac{1}{2}MV_{\text{com}}^2$

$$L = \frac{2}{5}MR^2 \frac{V_{\text{com}}}{R} \quad K = \frac{1}{2} \left(\frac{2}{5}MR^2 \right) \frac{V_{\text{com}}^2}{R^2} + \frac{1}{2}MV_{\text{com}}^2$$

$$L = \frac{2MRV_{\text{com}}}{5} \quad K = \frac{7}{10}MV_{\text{com}}^2$$

Ratio $\frac{L}{K} = \frac{4}{7} \frac{R}{V_{\text{com}}} = \frac{\pi}{22} \Rightarrow \omega = \frac{4}{7} \times \frac{22}{22} \times 7 = 4$

60. From the given transfer characteristic of a transistor in CE configuration, the value of power gain of this configuration is 10^x , for $R_B = 10 \text{ k}\Omega$, and $R_C = 1 \text{ k}\Omega$. The value of x is _____.

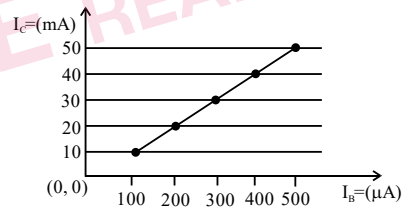

Official Ans. by NTA (3)

Sol. Power gain

$$\Rightarrow A_v \cdot A_1 = B \frac{R_C}{R_B} \cdot B = B^2 \frac{R_C}{R_B}$$

$$= \left(\frac{(20-10) \times 10^{-3}}{(200-100) \times 10^{-6}} \right) \times \frac{1 \times 10^3}{10 \times 10^3} = 10^3$$

Hence $x = 3$

CHEMISTRY

TEST PAPER WITH SOLUTIONS

SECTION-A

61. In the reaction given below

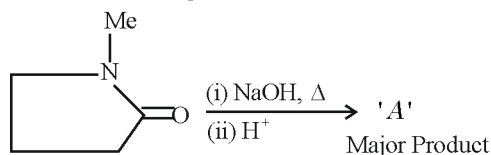

'A' is

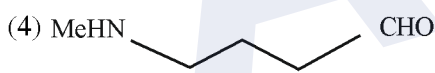
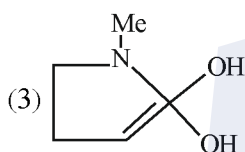
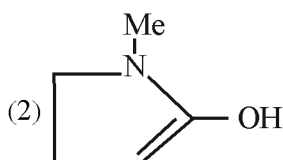
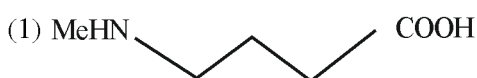

Official Ans. by NTA (1)

Sol.

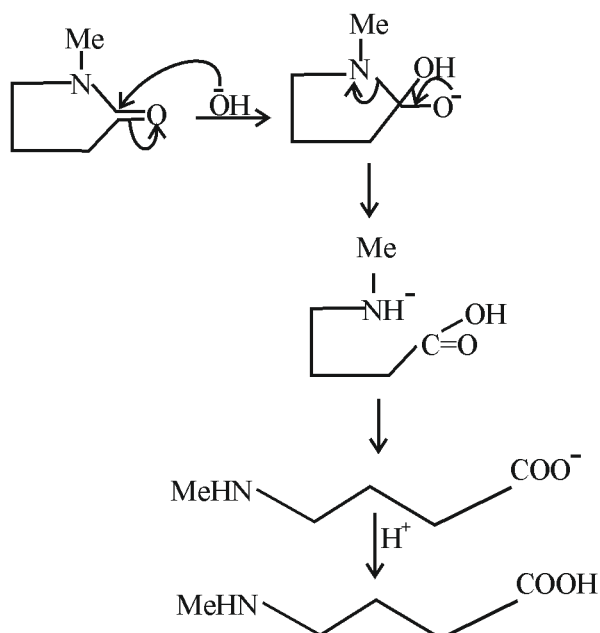

62. Given below are two statements:

Statement-I Permutit process is more efficient compared to the synthetic resin method for the softening of water.

Statement-II: Synthetic resin method results in the formation of soluble sodium salts.

In the light of the above statements, choose the most appropriate answer from the options given below:

- (1) Both the Statements I and II are correct
- (2) Statement I is correct but Statement II is incorrect
- (3) Statement I is incorrect but Statement II is correct
- (4) Both the Statements I and II are incorrect

Official Ans. by NTA (4)

Sol. Nowadays hard water is softened by using synthetic ion exchangers. This method is more efficient than zeolite process/Permutit process

63. The mismatched combinations are

- A. Chlorophyll - Co
- B. Water hardness - EDTA
- C. Photography - $[Ag(CN)_2]^-$
- D. Wilkinson catalyst - $[(Ph_3P)_3RhCl]$
- E. Chelating ligand - D - Penicillamine

Choose the correct answer from the options given below:

- (1) A and C Only
- (2) A and E Only
- (3) D and E Only
- (4) A, C and E Only

Official Ans. by NTA (1)

Sol. Mg is present in chlorophyll and in black and white photography the developed film is fixed by washing with hypo solution which dissolves the undecomposed AgBr to form a complex ion $[Ag(S_2O_3)_2]^{3-}$

64. In which of the following processes, the bond order increases and paramagnetic character changes to diamagnetic one?

- (1) $O_2 \rightarrow O_2^{2-}$
- (2) $NO \rightarrow NO^+$
- (3) $N_2 \rightarrow N_2^+$
- (4) $O_2 \rightarrow O_2^+$

Official Ans. by NTA (2)

Sol. NO is paramagnetic with BO = 2.5, NO^+ is diamagnetic with BO = 3

65. The incorrect statement from the following for borazine is:

- (1) It has electronic delocalization
- (2) It contains banana bonds.
- (3) It can react with water.
- (4) It is a cyclic compound.

Official Ans. by NTA (3)

Sol. Borazine is $B_3N_3H_6$

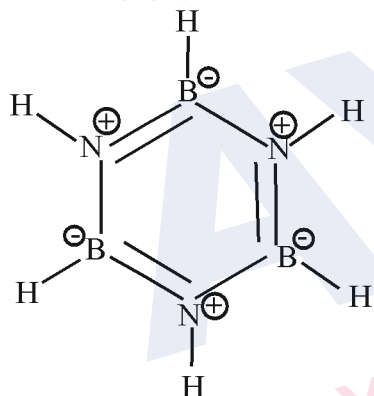

66. Among the following compounds, the one which shows highest dipole moment is

- (1)
- (2)
- (3)
- (4)

Official Ans. by NTA (1)

Sol. Among the given compounds, the following compound has the highest dipole moment because both the +ve and -ve ends acquire aromaticity.

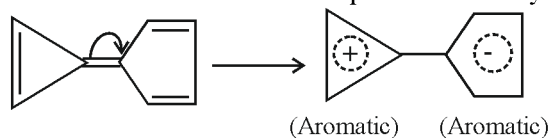

67. Match the following

Column -A		Column-B	
a	Nylon 6	I	Natural Rubber
b	Vulcanized Rubber	II	Cross Linked
c	cis-1,4-polyisoprene	III	Caprolactam
d	Polychloroprene	IV	Neoprene

Choose the correct answer from option given below:

- (1) a \rightarrow IV, b-III, c \rightarrow II, d \rightarrow I
- (2) a \rightarrow III, b \rightarrow IV, c \rightarrow I, d \rightarrow II
- (3) a \rightarrow II, b \rightarrow III, c \rightarrow IV, d \rightarrow I
- (4) a \rightarrow III, b \rightarrow II, c \rightarrow I, d \rightarrow IV

Official Ans. by NTA (4)

Sol. Nylon-6 – Caprolactam (Monomer)

Natural rubber – Isoprene (Monomer)

Vulcanized rubber – Sulphur containing rubber

Neoprene – Chloroprene (Monomer)

68. Major product

In the above reaction. Left hand side and right hand side rings are named as 'A' and 'B' respectively. They undergo ring expansion. The correct statement for this process is:

- (1) Finally both rings will become six membered each.
- (2) Finally both rings will become five membered each.
- (3) Only 'A' will become 6 membered.
- (4) Ring expansion can go upto seven membered rings

Official Ans. by NTA (1)

Sol.

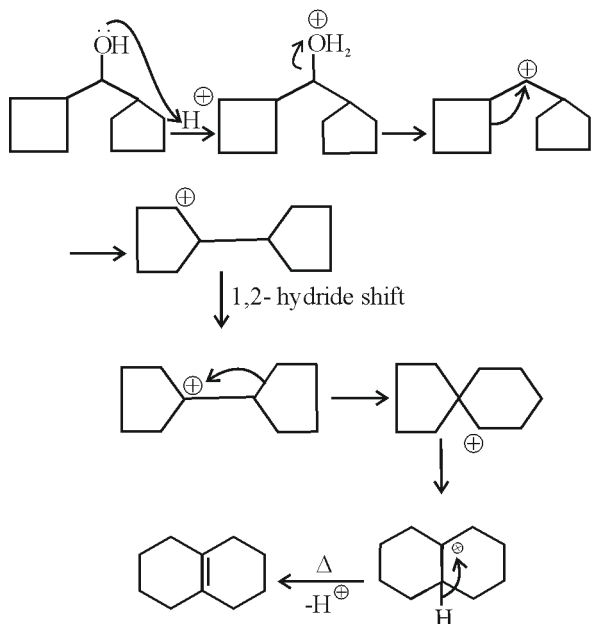

69. The radical which mainly causes ozone depletion in the presence of UV radiations is:

- (1) CH_3^\bullet (2) NO^\bullet
(3) Cl^\bullet (4) $\dot{O}H$

Official Ans. by NTA (3)

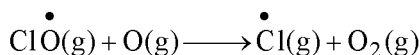
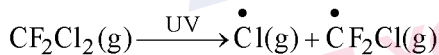
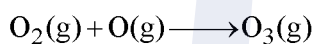

70. In the following reaction 'X' is

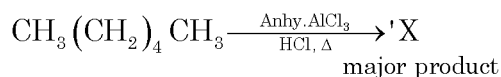

- (1) $CH_3(CH_2)_4CH_2Cl$
(2) $Cl-CH_2-(CH_2)_4-CH_2-Cl$
(3) $CH_3CH(CH_3)-(CH_2)_2CH_3$

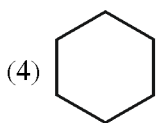

Official Ans. by NTA (3)

Sol. n-alkanes on heating in this presence of anhydrous $AlCl_3$ and hydrogen chloride gas isomerise to branched chain alkanes. The major product has one methyl side chain.

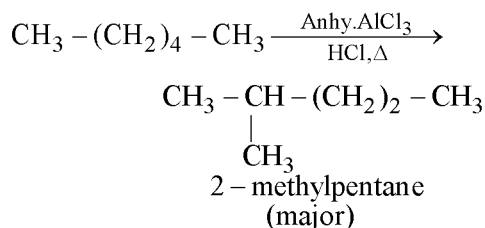

71. 2-Methyl propyl bromide reacts with $C_2H_5O^-$ and gives 'A' whereas on reaction with C_2H_5OH it gives 'B'. The mechanism followed in these reactions and the products 'A' and 'B' respectively are:

- (1) S_N2 , A = iso-butyl ethyl ether; S_N1 , B = tert-butyl ethyl ether
(2) S_N1 , A = tert-butyl ethyl ether; S_N1 , B = 2-butyl ethyl ether
(3) S_N1 , A = tert-butyl ethyl ether; S_N2 , B = iso-butyl ethyl ether
(4) S_N2 , A = 2-butyl ethyl ether; S_N2 , B = iso-butyl ethyl ether

Official Ans. by NTA (1)

Sol.

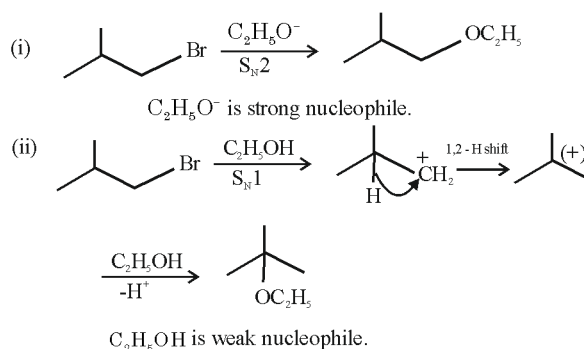

72. D- (+)- Glyceraldehyde $\xrightarrow{(i) HCN}$
 $\xrightarrow{(ii) H_2O/H^+}$
(iii) HNO_3

The products formed in the above reaction are

- (1) Two optically active products
(2) One optically active and one meso product
(3) One optically inactive and one meso product.
(4) Two optically inactive products

Official Ans. by NTA (2)

Sol.

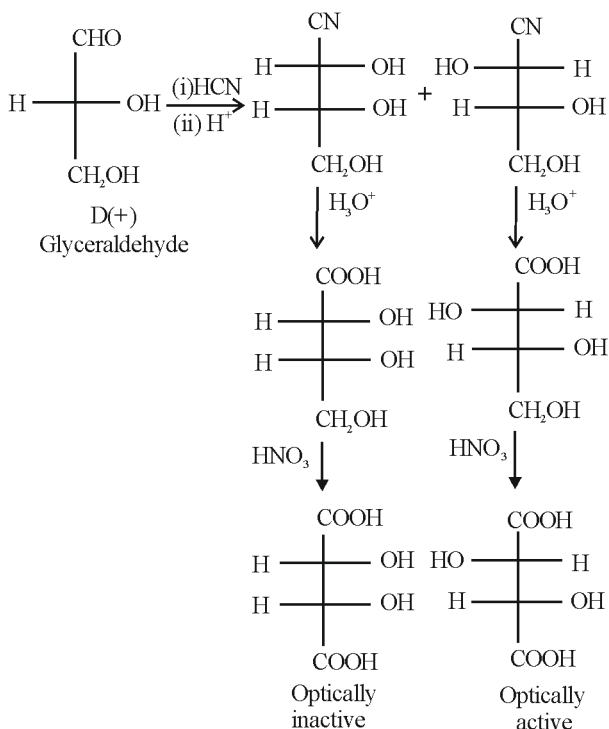

73. Which one of the following is most likely a mismatch?

- (1) Zinc- Liquefaction
- (2) Titanium – van Arkel method
- (3) Nickel – Mond process
- (4) Copper - Electrolysis

Official Ans. by NTA (1)

Sol. Zinc is refined by distillation method, which is used for metals having low boiling point.

74. ClF_5 at room temperature is a:

- (1) Colourless gas with trigonal bipyramidal geometry.
- (2) Colourless gas with square pyramidal geometry
- (3) Colourless liquid with square pyramidal geometry
- (4) Colourless liquid with trigonal bipyramidal geometry.

Official Ans. by NTA (3)

Sol.

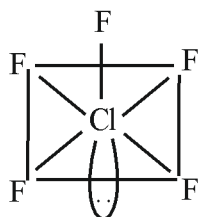

ClF_5 is colourless liquid.

75. $\text{Be}(\text{OH})_2$ react with $\text{Sr}(\text{OH})_2$ to yield an ionic salt. Choose the incorrect option related to this reaction from the following:

- (1) Be is tetrahedrally coordinated in the ionic salt.
- (2) The reaction is an example of acid - base neutralization reaction.
- (3) Both Sr and Be elements are present in the ionic salt.
- (4) The elements Be is present in the cationic part of the ionic salt.

Official Ans. by NTA (4)

Sol. $\text{Be}(\text{OH})_2$ is amphoteric in nature.

$\text{Sr}(\text{OH})_2$ is basic in nature.

These two undergo acid – base reaction to form a salt.

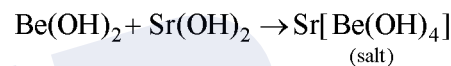

76. In the reaction given below

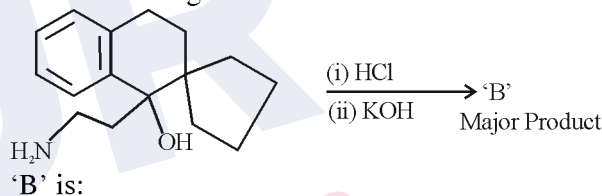

- (1)
- (2)
- (3)
- (4)

Official Ans. by NTA (3)

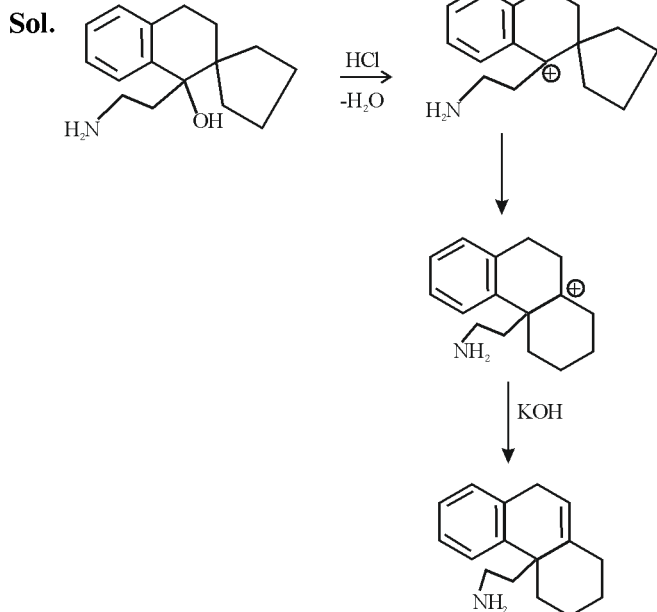

77. Which of the following statements are **not** correct?
- The electron gain enthalpy of F is more negative than that of Cl
 - Ionization enthalpy decreases in a group of periodic table
 - The electronegativity of an atom depends upon the atoms bonded to it.
 - Al_2O_3 and NO are examples of amphoteric oxides.

Choose the most appropriate answer from the options given below:

- A, B, C, and D
- A, C and D Only
- B and D Only
- A, B and D Only

Official Ans. by NTA (2)

Sol. Electronegativity of an element depends on the atom with which it is attached.

NO = neutral oxide

Al_2O_3 = amphoteric oxide

78. The energy of an electron in the first Bohr orbit of hydrogen atom is $-2.18 \times 10^{-18} \text{ J}$. Its energy in the third Bohr orbit is _____.

- $\frac{1}{27}$ of this value
- One third of this value
- Three times of this value
- $\frac{1}{9}$ th of this value

Official Ans. by NTA (4)

Sol.

$$E_n = \frac{-2.18 \times 10^{-18} Z^2}{n^2}$$

i.e. $E_n \propto \frac{1}{n^2}$

79. What happens when a lyophilic sol is added to a lyophobic sol?

- Lyophilic sol is dispersed in lyophobic sol.
- Film of lyophobic sol is formed over lyophilic sol.
- Lyophobic sol is coagulated
- Film of lyophilic sol is formed over lyophobic sol.

Official Ans. by NTA (4)

Sol. Lyophilic sol is used as protective action for lyophobic sol. It forms a layer / film around the lyophobic sol.

80. The pair of lanthanides in which both elements have high third -ionization energy is:

- Eu, Gd
- Eu, Yb
- Lu, Yb
- Dy, Gd

Official Ans. by NTA (2)

Sol. $\left. \begin{array}{l} \text{Eu}^{+2} : [\text{Xe}]4f^7 \\ \text{Yb}^{+2} : [\text{Xe}]4f^{14} \end{array} \right\} \text{High IE due to half filled \& \text{fully filled configurations}$

SECTION-B

81. For the given reaction

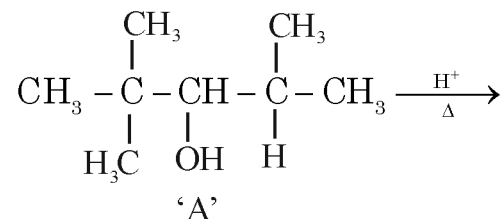

The total number of possible products formed by tertiary carbocation of A is _____.

Official Ans. by NTA (4)

Sol.

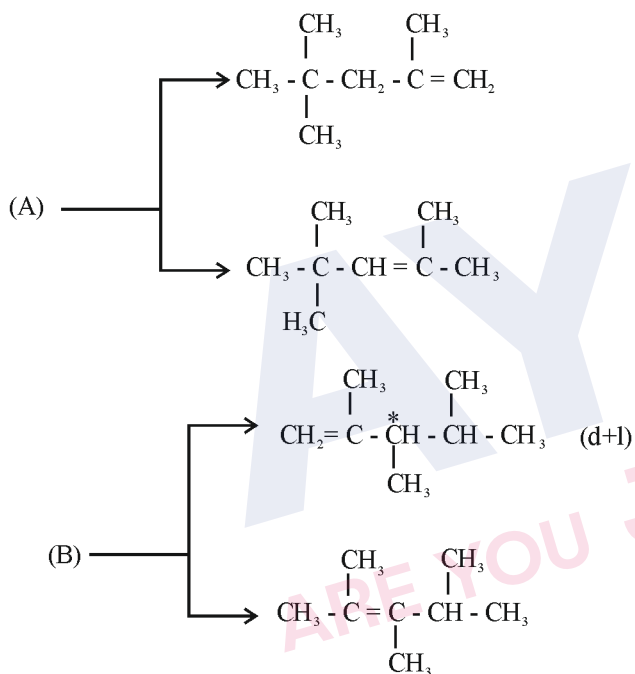
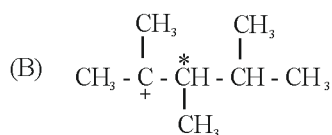
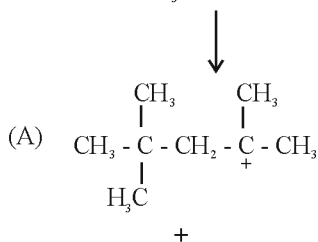
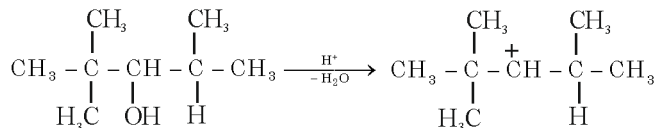

82. Solution of 12 g of non – electrolyte (A) prepared by dissolving it in 1000 mL of water exerts the same osmotic pressure as that of 0.05 M glucose solution at the same temperature. The empirical formula of A is CH_2O . The molecular mass of A is _____ g. (Nearest integer)

Official Ans. by NTA (240)

Sol. For Isotonic solutions

$$\pi_1 = \pi_2$$

$$\Rightarrow C_1 = C_2$$

$$\frac{12}{x} = 0.05 [x \rightarrow \text{Molar Mass of A}]$$

$$X = 240$$

83. 25.0 mL of 0.050 M $\text{Ba}(\text{NO}_3)_2$ is mixed with 25.0 mL of 0.020 M NaF. K_{sp} of BaF_2 is 0.5×10^{-6} at 298 K. The ratio of $[\text{Ba}^{2+}][\text{F}^-]^2$ and K_{sp} is _____ (Nearest integer)

Official Ans. by NTA (5)

Sol.
$$[\text{Ba}^{+2}] = \frac{25 \times 0.05}{50} = 0.025\text{M}$$

$$[\text{F}^-] = \frac{25 \times 0.02}{50} = 0.01\text{M}$$

$$[\text{Ba}^{+2}][\text{F}^-]^2 = 25 \times 10^{-7}$$

$$K_{sp} = 5 \times 10^{-7} \quad (\text{given})$$

$$\text{Ratio} = \frac{[\text{Ba}^{+2}][\text{F}^-]^2}{K_{sp}} = 5$$

84. $\text{A}_2 + \text{B}_2 \rightarrow 2\text{AB}$. $\Delta H_f^\circ = -200 \text{ kJ mol}^{-1}$

AB, A_2 and B_2 are diatomic molecule. If the bond enthalpies of A_2 , B_2 and AB are in the ratio 1:0.5:1, then the bond enthalpy of A_2 is _____ kJ mol^{-1} (Nearest integer)

Official Ans. by NTA (400)

Sol. $\text{A}_2 + \text{B}_2 \rightarrow 2\text{AB}$; $\Delta H_f^\circ = -200 \text{ kJ mol}^{-1}$

$$\Rightarrow \Delta H_f^\circ (\text{AB}) = -200 \text{ kJ mol}^{-1}$$

$$\therefore \Delta H_R^\circ \text{ for reaction } \text{A}_2 + \text{B}_2 \rightarrow 2\text{AB} \text{ is } -400 \text{ kJ mol}^{-1}$$

Given: Bond Enthalpy of A_2, B_2 and AB is 1 : 0.5 : 1

Assuming bond enthalpy of A_2 be $x \text{ kJ mol}^{-1}$

$$\therefore \text{Bond enthalpy } \text{B}_2 = 0.5x \text{ kJ mol}^{-1}$$

$$\therefore \text{Bond enthalpy } \text{AB} = (x) \text{ kJ mol}^{-1}$$

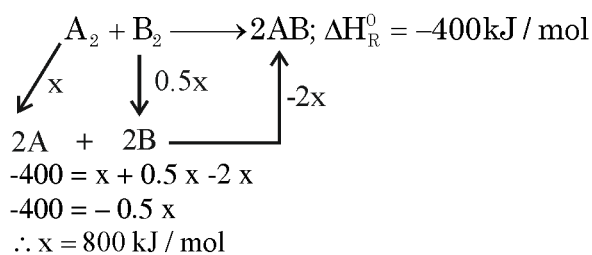

85. An organic compound gives 0.220 g of CO₂ and 0.126 g of H₂O on complete combustion. If the % of carbon is 24 then the % hydrogen is _____ × 10⁻¹. (Nearest integer)

Official Ans. by NTA (56)

Sol. Moles of CO₂ = $\frac{0.22}{44} = \frac{1}{200}$

∴ Moles of carbon
 = (Moles of CO₂) × 1
 = $\frac{1}{200}$

∴ wt. of C = $\frac{1}{200} \times 12 = 0.06$

% of C = $\frac{0.06}{W} \times 100 = 24$

(W = Wt. of Organic Compound)

W = 0.25

Moles of H₂O = $\frac{0.126}{18} = 0.007$

∴ Moles of H atom = 2 × 0.007 = 0.014

% of Hydrogen = $\frac{0.014 \times 1}{W} \times 100$

= $\frac{0.014 \times 1}{0.25} \times 100$

= 5.6

= 56 × 10⁻¹

86. 20 mL of calcium hydroxide was consumed when it was reacted with 10 mL of unknown solution of H₂SO₄. Also 20 mL standard solution of 0.5 M HCl containing 2 drops of phenolphthalein was titrated with calcium hydroxide the mixture showed pink colour when burette displayed the value of 35.5 mL whereas the burette showed 25.5 mL initially. The concentration of H₂SO₄ is _____ M (Nearest integer)

Official Ans. by NTA (1)

Sol. Reaction with HCl

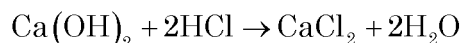

Volume of Ca(OH)₂ = 10 ml

Volume of HCl = 20 ml

Concentration of HCl = 0.5 M.

No. of milli moles of HCl = 10

No. of milli moles of Ca(OH)₂ = 5.

i.e. $M_{\text{Ca(OH)}_2} = \frac{\text{no. of milli moles}}{V(\text{ml})} = \frac{5}{10}$
 = 0.5 M.

Reaction with H₂SO₄

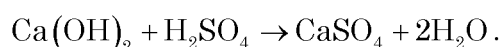

No. of milli moles of Ca(OH)₂ = 20 × 0.5
 = 10

i.e. no. of milli moles of H₂SO₄ = 10

⇒ $M_{\text{H}_2\text{SO}_4} = \frac{\text{no. of mil moles}}{V(\text{ml})}$
 = $\frac{10}{10}$
 = 1 M

87. A certain quantity of real gas occupies a volume of 0.15 dm³ at 100 atm and 500 K when its compressibility factor is 1.07. Its volume at 300 atm and 300K (When its compressibility factor is 1.4) is _____ × 10⁻⁴ dm³ (Nearest integer)

Official Ans. by NTA (392)

Sol. $z = \frac{PV}{nRT}$; $n = \frac{PV}{ZRT}$

Z₁ = 1.07, P₁ = 100atm, V₁ = 0.15L, T₁ = 500K

Z₂ = 1.4, P₂ = 300atm, T₂ = 300K, V₂ = ?

$$\frac{P_1 V_1}{Z_1 R T_1} = \frac{P_2 V_2}{Z_2 R T_2} = n$$

$$V_2 = \frac{1.4}{1.07} \times .03$$

$$= 392 \times 10^{-4} \text{ dm}^3$$

88. $t_{87.5}$ is the time required for the reaction to undergo 87.5% completion and t_{50} is the time required for the reaction to undergo 50% completion. The relation between $t_{87.5}$ and t_{50} for a first order reaction is $t_{87.5} = x \times t_{50}$

The value of x is _____ (Nearest integer)

Official Ans. by NTA (3)

Sol. $A_t = A_0 \times \frac{12.5}{100} = \frac{A_0}{8}$ [87.5% complete]

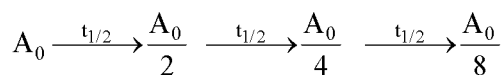

$$t_{87.5} = 3t_{1/2}$$

$$\therefore x = 3$$

89. KMnO_4 is titrated with ferrous ammonium sulphate hexahydrate in presence of dilute H_2SO_4 . Number of water molecules produced for 2 molecules of KMnO_4 is _____.

Official Ans. by NTA (68)

Sol. By balancing the redox reaction we get

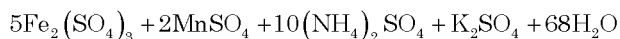

90. A metal surface of 100 cm^2 area has to be coated with nickel layer of thickness 0.001mm. A current of 2A was passed through a solution of $\text{Ni}(\text{NO}_3)_2$ for 'x' seconds to coat the desired layer. The value of x is _____ (Nearest integer)

(ρ_{Ni} (density of Nickel) is 10 gmL^{-1} , Molar mass of Nickel is 60 gmol^{-1} $F = 96500 \text{ C mol}^{-1}$)

Official Ans. by NTA (161)

Sol. $W = z \times i \times t$.

$$\text{Density} \times \text{volume} = \frac{E \times i \times t}{96500}$$

$$10 \times 100 \times 0.0001 = \frac{\left(\frac{\text{atomic wt.}}{\text{v.f}}\right) \times 2 \times x}{96500} \quad (\text{v.f} = 2)$$

$$\therefore x = 161 \text{ sec.}$$