

FINAL JEE-MAIN EXAMINATION – JUNE, 2022

(Held On Monday 27th June, 2022)

TIME : 9:00 AM to 12:00 PM

PHYSICS

TEST PAPER WITH SOLUTION

SECTION-A

1. A projectile is launched at an angle ‘ α ’ with the horizontal with a velocity 20 ms^{-1} . After 10 s, its inclination with horizontal is ‘ β ’. The value of $\tan\beta$ will be : ($g = 10 \text{ ms}^{-2}$)
- (A) $\tan \alpha + 5 \sec \alpha$ (B) $\tan \alpha - 5 \sec \alpha$
(C) $2 \tan \alpha - 5 \sec \alpha$ (D) $2 \tan \alpha + 5 \sec \alpha$

Official Ans. by NTA (B)

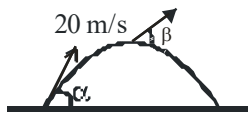

Sol.

$$v_x = u_x = 20 \cos \alpha$$

$$v_y = 20 \sin \alpha - 10 \times 10$$

$$\tan \beta = \frac{v_y}{v_x} = \frac{20 \sin \alpha - 100}{20 \cos \alpha}$$

$$= \tan \alpha - 5 \sec \alpha$$

2. A girl standing on road holds her umbrella at 45° with the vertical to keep the rain away. If she starts running without umbrella with a speed of $15\sqrt{2} \text{ kmh}^{-1}$, the rain drops hit her head vertically. The speed of rain drops with respect to the moving girl is :

- (A) 30 kmh^{-1} (B) $\frac{25}{\sqrt{2}} \text{ kmh}^{-1}$
(C) $\frac{30}{\sqrt{2}} \text{ kmh}^{-1}$ (D) 25 kmh^{-1}

Official Ans. by NTA (C)

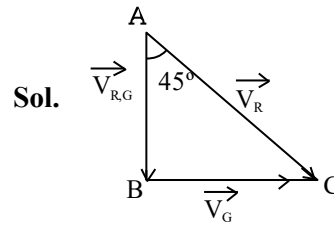

Sol.

$$V = \tan \theta = \frac{V_G}{V_{RG}}$$

$$1 = \frac{V_G}{V_{RG}} \Rightarrow 15\sqrt{2} = V_{RG}$$

3. A sliver wire has mass $(0.6 \pm 0.006) \text{ g}$, radius $(0.5 \pm 0.005) \text{ mm}$ and length $(4 \pm 0.04) \text{ cm}$. The maximum percentage error in the measurement of its density will be :
- (A) 4% (B) 3%
(C) 6% (D) 7%

Official Ans. by NTA (A)

Sol. $M = (0.6 \pm 0.006) \text{ g}$

$$r = (0.5 \pm 0.005) \text{ mm}$$

$$l = (4 \pm 0.04) \text{ cm}$$

$$\rho = \frac{m}{V}$$

$$\Rightarrow \frac{\Delta \rho}{\rho} = \frac{\Delta m}{m} + \frac{2\Delta r}{r} + \frac{\Delta l}{l}$$

(Volume of cylinder = $\pi r^2 l$)

$$= \frac{0.006}{0.6} + \frac{2 \times 0.005}{0.5} + \frac{0.04}{4}$$

$$100 \times \frac{\Delta \rho}{\rho} = 4 \times 10^{-2} \times 100$$

$$\frac{\Delta \rho}{\rho} \times 100 = 4\%$$

4. A system of two blocks of masses $m = 2 \text{ kg}$ and $M = 8 \text{ kg}$ is placed on a smooth table as shown in figure. The coefficient of static friction between two blocks is 0.5. The maximum horizontal force F that can be applied to the block of mass M so that the blocks move together will be :

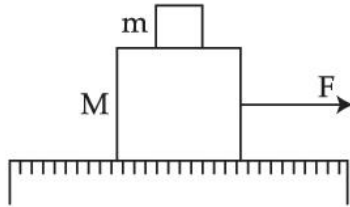

- (A) 9.8 N (B) 39.2 N
(C) 49 N (D) 78.4 N

Official Ans. by NTA (C)

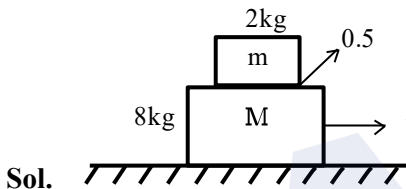

$$(a_A)_{\max} = 0.5g = 4.9 \text{ m/s}^2$$

For moving together



$$F_{\max} = m_T a_A \\ = 10 \times 4.9 \\ = 49 \text{ N}$$

5. Two blocks of masses 10 kg and 30 kg are placed on the same straight line with coordinates (0, 0) cm and (x, 0) cm respectively. The block of 10 kg is moved on the same line through a distance of 6 cm towards the other block. The distance through which the block of 30 kg must be moved to keep the position of centre of mass of the system unchanged is :
- (A) 4 cm towards the 10 kg block
(B) 2 cm away from the 10 kg block
(C) 2 cm towards the 10 kg block
(D) 4 cm away from the 10 kg block

Official Ans. by NTA (C)

Sol. $\Delta x_G = \frac{m_1 \Delta x_1 + m_2 \Delta x_2}{m_1 + m_2}$

$$0 = \frac{10 \times 6 + 30(\Delta x_2)}{40}$$

$$\Delta x_2 = -2 \text{ cm}$$

Block of mass 30 kg will to move towards 10 kg.

6. A 72Ω galvanometer is shunted by a resistance of 8Ω . The percentage of the total current which passes through the galvanometer is :
- (A) 0.1% (B) 10 %
(C) 25% (D) 0.25%

Official Ans. by NTA (B)

Sol. $S = \frac{R_G}{\frac{I}{I_g} - 1}$

$$8 = \frac{72}{\frac{I}{I_g} - 1}$$

$$\frac{I}{I_g} - 1 = 9$$

$$\frac{I}{I_g} = 10 \Rightarrow \frac{I_g}{I} = \frac{1}{10} \quad \% I = \frac{I_g}{I} \times 100 = 10\%$$

7. Given below are two statements :
- Statement I :** The law of gravitation holds good for any pair of bodies in the universe.
Statement II : The weight of any person becomes zero when the person is at the centre of the earth.
In the light of the above statements, choose the correct answer from the options given below.
(A) Both statement I and Statement II are true
(B) Both statement I and Statement II are false
(C) Statement I is true but Statement II are false
(D) Statement I is false but Statement II is true

Official Ans. by NTA (A)

Sol. Since it is universal law so it hold good for any pair of bodies.

The value of g at centre is zero.

So statement I and Statement II are true.

8. What percentage of kinetic energy of a moving particle is transferred to a stationary particle when it strikes the stationary particle of 5 times its mass? (Assume the collision to be head-on elastic collision)
- (A) 50.0% (B) 66.6%
 (C) 55.5% (D) 33.3%

Official Ans. by NTA (C)

Sol. Velocity after collision

$$V_2 = \frac{(m_2 - m_1)u_2 + 2m_1u_1}{m_1 + m_2}$$

$$V_2 = \frac{(5m - m)0 + 2m.u_0}{m + 5m} = \frac{u_0}{3}$$

$$\% \Delta KE = \frac{\frac{1}{2}5m\left(\frac{u_0}{3}\right)^2 - 0}{\frac{1}{2}mu_0^2} \times 100$$

$$= \frac{5u_0^2}{9u_0^2} \times 100 = \frac{500}{9} = 55.6\%$$

9. The velocity of a small ball of mass 'm' and density d_1 , when dropped in a container filled with glycerine, becomes constant after some time. If the density of glycerine is d_2 , then the viscous force acting on the ball, will be :

- (A) $mg\left(1 - \frac{d_1}{d_2}\right)$ (B) $mg\left(1 - \frac{d_2}{d_1}\right)$
 (C) $mg\left(\frac{d_1}{d_2} - 1\right)$ (D) $mg\left(\frac{d_2}{d_1} - 1\right)$

Official Ans. by NTA (B)

$$F_V = mg - F_B$$

Sol. $= mg - \left(\frac{m}{d_1} \times d_2\right)g$

$$= mg\left(1 - \frac{d_2}{d_1}\right)$$

10. The susceptibility of a paramagnetic material is 99. The permeability of the material in Wb/A-m is : [Permeability of free space $\mu_0 = 4\pi \times 10^{-7} \text{Wb/A-m}$]

- (A) $4\pi \times 10^{-7}$ (B) $4\pi \times 10^{-4}$
 (C) $4\pi \times 10^{-5}$ (D) $4\pi \times 10^{-6}$

Official Ans. by NTA (C)

Sol. Susceptibility $\chi = 99$

$$\mu_r = \frac{\mu}{\mu_0} = 1 + \chi$$

$$\begin{aligned} \mu &= \mu_0(1 + \chi) \\ &= 4\pi \times 10^{-7}[1 + 99] \\ &= 4\pi \times 10^{-5} \end{aligned}$$

11. The current flowing through an ac circuit is given by

$$I = 5 \sin(120\pi t) \text{ A}$$

How long will the current take to reach the peak value starting from zero?

- (A) $\frac{1}{60} \text{ s}$ (B) 60s
 (C) $\frac{1}{120} \text{ s}$ (D) $\frac{1}{240} \text{ s}$

Official Ans. by NTA (D)

Sol. $\omega = 120\pi = \frac{2\pi}{T} \Rightarrow T = \frac{1}{60} \text{ sec}$

$$\text{time taken to reach peak value} = \frac{T}{4} = \frac{1}{240} \text{ s}$$

12. Match List-I with List-II :

List - I **List - II**

	List-I		List-II
(a)	Ultraviolet rays	(i)	Study crystal structure
(b)	Microwaves	(ii)	Greenhouse effect
(c)	Infrared waves	(iii)	Sterilizing surgical instrument
(d)	X-rays	(iv)	Radar system

Choose the correct answer from the options given below :

- (A) (a) - (iii), (b) - (iv), (c) - (ii), (d) - (i)
 (B) (a) - (iii), (b) - (i), (c) - (ii), (d) - (iv)
 (C) (a) - (iv), (b) - (iii), (c) - (ii), (d) - (i)
 (D) (a) - (iii), (b) - (iv), (c) - (i), (d) - (ii)

Official Ans. by NTA (A)

Sol. (Fact)

13. An α particle and a carbon 12 atom has same kinetic energy K . The ratio of their de-Broglie wavelength ($\lambda_\alpha : \lambda_{C_{12}}$) is :

- (A) $1 : \sqrt{3}$ (B) $\sqrt{3} : 1$
 (C) $3 : 1$ (D) $2 : \sqrt{3}$

Official Ans. by NTA (B)

Sol. $k = \frac{P^2}{2m} \Rightarrow P \propto \sqrt{m}$

Now $\lambda = \frac{h}{p}$

So, $\lambda \propto \frac{1}{p} \Rightarrow \lambda \propto \frac{1}{\sqrt{m}}$

$\frac{\lambda_\alpha}{\lambda_{C_{12}}} = \frac{\sqrt{3}}{1}$

14. A force of 10N acts on a charged particle placed between two plates of a charged capacitor. If one plate of capacitor is removed, then the force acting on that particle will be :

- (A) 5 N (B) 10 N
 (C) 20 N (D) Zero

Official Ans. by NTA (A)

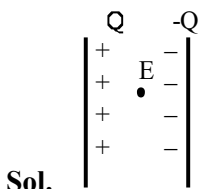

$F = qE = q \left(\frac{Q}{A \epsilon_0} \right) = \frac{qQ}{A \epsilon_0} = 10N$

Now, when one plate is removed.

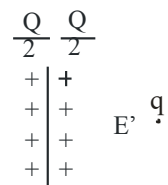

$E' = \frac{Q}{2A \epsilon_0}$

$F = qE' = \frac{Qq}{2A \epsilon_0} = 5N$

15. The displacement of simple harmonic oscillator after 3 seconds starting from its mean position is equal to half of its amplitude. The time period of harmonic motion is :

- (A) 6 s (B) 8 s
 (C) 12s (D) 36 s

Official Ans. by NTA (D)

Sol. $X = A \sin \omega t \left(t = 3, X = \frac{A}{2} \right)$

$\Rightarrow \frac{A}{2} = A \sin 3\omega$

$\Rightarrow \sin 3\omega = \frac{1}{2}$

$\Rightarrow 3\omega = \frac{\pi}{6}$

$\Rightarrow \omega = \frac{\pi}{18} = \frac{2\pi}{T}$

$\Rightarrow T = 36s$

16. An observer moves towards a stationary source of sound with a velocity equal to one-fifth of the velocity of sound. The percentage change in the frequency will be :

- (A) 20% (B) 10%
 (C) 5% (D) 0%

Official Ans. by NTA (A)

Sol. $f_0 = \left(\frac{v + v_0}{v} \right) f_s$

$f_0 = \left(\frac{v + \frac{v}{5}}{v} \right) f_s$

$f_0 = \frac{6}{5} f_s$

% change = $\frac{f_0 - f_s}{f_s} \times 100$

= $\frac{1}{5} \times 100 = 20\%$

17. Consider a light ray travelling in air is incident into a medium of refractive index $\sqrt{2n}$. The incident angle is twice that of refracting angle. Then, the angle of incidence will be :

- (A) $\sin^{-1}(\sqrt{n})$ (B) $\cos^{-1}\left(\sqrt{\frac{n}{2}}\right)$
 (C) $\sin^{-1}(\sqrt{2n})$ (D) $2\cos^{-1}\left(\sqrt{\frac{n}{2}}\right)$

Official Ans. by NTA (D)

Sol. $i = 2r$
 $\sin i \times n_1 = \sin r \times n_2$
 $\sin i \times 1 = \sin \frac{i}{2} \times \sqrt{2n}$

$$\frac{\sin i}{\sin \frac{i}{2}} = \sqrt{2n}$$

$$\frac{2 \sin \frac{i}{2} \cos \frac{i}{2}}{\sin \frac{i}{2}} = \sqrt{2n}$$

$$\cos \frac{i}{2} = \sqrt{\frac{n}{2}}$$

$$\frac{i}{2} = \cos^{-1}\left(\sqrt{\frac{n}{2}}\right)$$

$$i = 2\cos^{-1}\left(\sqrt{\frac{n}{2}}\right)$$

18. A hydrogen atom in its ground state absorbs 10.2 eV of energy. The angular momentum of electron of the hydrogen atom will increase by the value of : (Given, Planck's constant = 6.6×10^{-34} Js)

- (A) 2.10×10^{-34} Js (B) 1.05×10^{-34} Js
 (C) 3.15×10^{-34} Js (D) 4.2×10^{-34} Js

Official Ans. by NTA (B)

Sol. $13.6\left(\frac{1}{1^2} - \frac{1}{n^2}\right) = 10.2$

$$n = 2$$

$$L_i = \frac{h}{2\pi} \times 1$$

$$L_f = \frac{2h}{2\pi}$$

$$\Delta L = L_f - L_i = \frac{h}{2\pi} = \frac{6.6 \times 10^{-34}}{2 \times \frac{22}{7}}$$

$$= 1.05 \times 10^{-34} \text{ J-s}$$

19. Identify the correct Logic Gate for the following output (Y) of two inputs A and B.

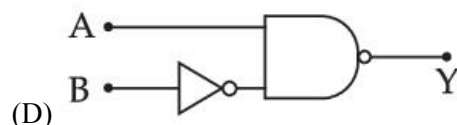
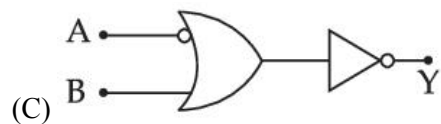
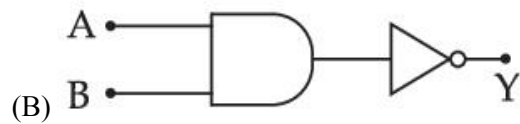
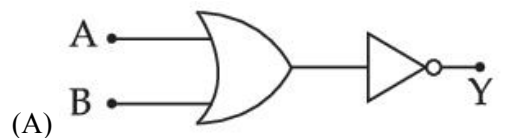
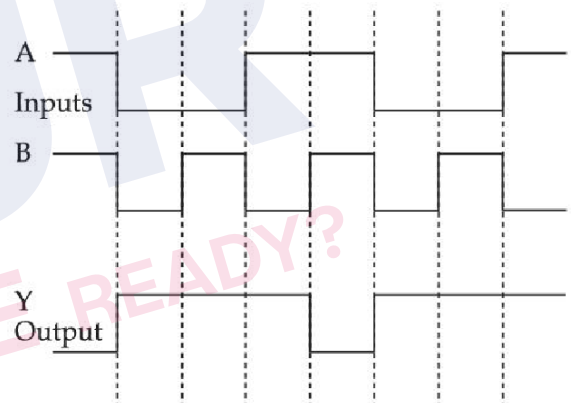

Official Ans. by NTA (B)

Sol.

A	B	Y
1	1	0
0	0	1
0	1	1
1	0	1
1	1	0
0	0	1
0	1	1
1	0	1
NAND Gate		

$$Y = \overline{A.B}$$

20. A mixture of hydrogen and oxygen has volume 2000 cm^3 , temperature 300 K , pressure 100 kPa and mass 0.76 g . The ratio of number of moles of hydrogen to number of moles of oxygen in the mixture will be :

- (A) $\frac{1}{3}$ (B) $\frac{3}{1}$
(C) $\frac{1}{16}$ (D) $\frac{16}{1}$

Official Ans. by NTA (B)

Sol. $PV = nRT$

$$n = \frac{100 \times 10^3 \times 2000 \times 10^{-6}}{\frac{25}{3} \times 300}$$

$$n = 80 \times 10^{-3}$$

$$n_1 + n_2 = 0.08$$

$$n_1 \times 2 + n_2 \times 32 = 0.76$$

$$(0.08 - n_2) \times 2 + n_2 (32) = 0.76$$

$$n_2 = 0.02$$

$$n_1 = 0.06$$

$$\frac{n_1}{n_2} = \frac{3}{1}$$

SECTION-B

1. In a Carnot engine, the temperature of reservoir is 527°C and that of sink is 200 K . If the workdone by the engine when it transfers heat from reservoir to sink is 12000 kJ , the quantity of heat absorbed by the engine from reservoir is _____ $\times 10^6 \text{ J}$.

Official Ans. by NTA (16)

Sol. $(T_2) T_{\text{sink}} = 200 \text{ K}$

$$(T_1) T_{\text{Reservoir}} = 527 + 273 = 800 \text{ K}$$

$$W = 12000 \text{ kJ} = 12 \times 10^6 \text{ J}$$

$$Q_1 = ?$$

$$\eta = 1 - \frac{T_2}{T_1} = \frac{W}{Q_1} = 1 - \frac{200}{800} = \frac{12 \times 10^6}{Q_1}$$

$$\frac{3}{4} = \frac{12 \times 10^6}{Q_1} = Q_1 = 16 \times 10^6 \text{ J}$$

2. A 220 V , 50 Hz AC source is connected to a 25 V , 5 W lamp and an additional resistance R in series (as shown in figure) to run the lamp at its peak brightness, then the value of R (in ohm) will be _____.

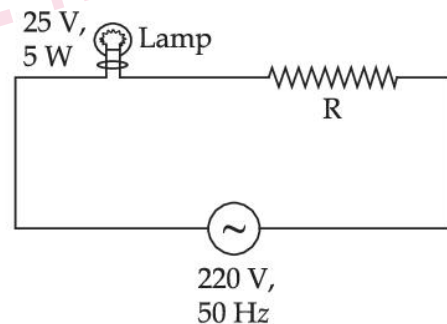

Official Ans. by NTA (975)

Sol. $P = Vi$

$$5 = 25i$$

$$i = \frac{1}{5}$$

$$V_R = iR$$

$$(220 - 25) = \frac{1}{5} R$$

$$R = 195 \times 5 = 975 \Omega$$

3. In Young's double slit experiment the two slits are 0.6 mm distance apart. Interference pattern is observed on a screen at a distance 80 cm from the slits. The first dark fringe is observed on the screen directly opposite to one of the slits. The wavelength of light will be _____ nm.

Official Ans. by NTA (450)

Sol. $d = 0.6 \times 10^{-3}$
 $D = 80 \times 10^{-2}$

$$\text{1st Dark fringe} = \frac{D\lambda}{2d} = \frac{d}{2}, \quad \lambda = \frac{d^2}{D}$$

$$= 450 \times 10^{-9} \text{ m}$$

4. A beam of monochromatic light is used to excite the electron in Li^{++} from the first orbit to the third orbit. The wavelength of monochromatic light is found to be $x \times 10^{-10} \text{ m}$. The value of x is _____. [Given $hc = 1242 \text{ eV nm}$]

Official Ans. by NTA (114)

Sol. $Z = 3$

$$\frac{1}{\lambda} = RZ^2 \left(\frac{1}{n_1^2} - \frac{1}{n_2^2} \right)$$

$$n_1 = 1, \quad n_2 = 3,$$

$$\frac{1}{\lambda} = R(9) \left(\frac{1}{1} - \frac{1}{9} \right) = 8R$$

$$\lambda = \frac{1}{8R} = 114 \times 10^{-10} \text{ m}$$

5. A cell, shunted by a 8Ω resistance, is balanced across a potentiometer wire of length 3m. The balancing length is 2 m when the cell is shunted by 4Ω resistance. The value of internal resistance of the cell will be _____ Ω .

Official Ans. by NTA (8)

Sol. $\frac{V_1}{V_2} = \frac{3}{2} = \frac{E - i_1 r}{E - i_2 r}$

$$= \frac{E - \frac{E}{8+r} \times r}{E - \frac{E}{4+r} \times r}$$

$$\frac{3}{2} = \frac{8(4+r)}{4(8+r)}$$

$$24 + 3r = 16 + 4r$$

$$r = 8 \Omega$$

6. The current density in a cylindrical wire of radius 4 mm is $4 \times 10^6 \text{ Am}^{-2}$. The current through the outer portion of the wire between radial distance $\frac{R}{2}$ and

R is _____ $\pi \text{ A}$.

Official Ans. by NTA (48)

Sol. $J = \frac{I}{A}$

$$I = JA$$

$$= 4 \times 10^6 \times \left[\pi R^2 - \pi \left(\frac{R}{2} \right)^2 \right]$$

$$= 4 \times 10^6 \times \pi R^2 \times \frac{3}{4}$$

$$= 4 \times 10^6 \times \pi \times (4 \times 10^{-3})^2 \times \frac{3}{4} = 48\pi \text{ A}$$

7. A capacitor of capacitance 50 pF is charged by 100 V source. It is then connected to another uncharged identical capacitor. Electrostatic energy loss in the process is _____ nJ.

Official Ans. by NTA (125)

Sol. Energy loss = $\frac{1}{2} \frac{C_1 C_2}{C_1 + C_2} (V_1 - V_2)^2$

$$= \frac{1}{2} \frac{50 \times 50 \times 10^{-12} \times 10^{-12}}{(50 + 50) 10^{-12}} (100 - 0)^2 = 125 \text{ nJ}$$

8. The height of a transmitting antenna at the top of a tower is 25 m and that of receiving antenna is, 49 m. The maximum distance between them, for satisfactory communication in LOS (Line-Of-Sight) is $K\sqrt{5} \times 10^2 m$. The value of K is _____ .
 [Assume radius of Earth is $64 \times 10^5 m$] (Calculate upto nearest integer value)

Official Ans. by NTA (192)

Sol. $LOS = \sqrt{2Rh_T} + \sqrt{2Rh_R}$
 $= \sqrt{2R}(\sqrt{h_T} + \sqrt{h_R})$
 $= \sqrt{2 \times 64 \times 10^5}(\sqrt{25} + \sqrt{49})$
 $= 192\sqrt{5} \times 10^2 m.$
 $K = 192$

9. The area of cross-section of a large tank is $0.5 m^2$. It has a narrow opening near the bottom having area of cross-section $1 cm^2$. A load of 25 kg is applied on the water at the top in the tank. Neglecting the speed of water in the tank, the velocity of the water, coming out of the opening at the time when the height of water level in the tank is 40 cm above the bottom, will be _____ cms^{-1} .
 [Take $g = 10 ms^{-2}$]

Official Ans. by NTA (300)

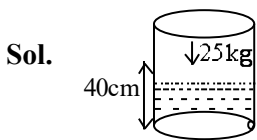

$$P_0 + \frac{250}{0.5} + \rho g(40 \times 10^{-2}) = P_0 + \frac{1}{2} \rho v^2$$

$$500 + \frac{1000 \times 10 \times 40}{100} = \frac{1}{2} \times 1000 \times v^2$$

$$V = 3 m/s$$

$$V = 300 cm/s$$

10. A pendulum of length 2 m consists of a wooden bob of mass 50 g. A bullet of mass 75 g is fired towards the stationary bob with a speed v . The bullet emerges out of the bob with a speed $\frac{v}{3}$ and the bob just completes the vertical circle. The value of v is _____ ms^{-1} . (if $g = 10 m/s^2$)

Official Ans. by NTA (10)

Sol. Considering Only Horizontal direction

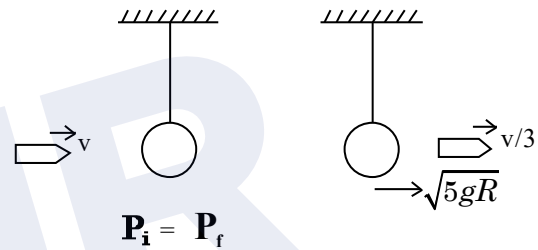

$$(75v) + 0 = 50(\sqrt{5gR}) + 75 \frac{v}{3}$$

$$75 \left(v - \frac{v}{3} \right) = 50\sqrt{100}$$

$$v = 10 m/s$$

FINAL JEE–MAIN EXAMINATION – JUNE, 2022

(Held On Monday 27th June, 2022)

TIME : 9 : 00 AM to 12 : 00 PM

CHEMISTRY

TEST PAPER WITH SOLUTION

SECTION-A

1. Given below are two statements : one is labelled as **Assertion (A)** and the other is labelled as **Reason (R)**

Assertion (A) : At 10°C, the density of a 5M solution of KCl [atomic masses of K and Cl are 39 & 35.5 g mol⁻¹]. The solution is cooled to -21°C. The molality of the solution will remain unchanged.

Reason (R) : The molality of a solution does not change with temperature as mass remains unaffected with temperature.

In the light of the above statements, choose the correct answer from the options given below:

- (A) Both (A) and (R) are true and (R) is the correct explanation of (A)
 (B) Both (A) and (R) are true but (R) is not the correct explanation of (A)
 (C) (A) is true but (R) is false
 (D) (A) is false but (R) is true

Official Ans. by NTA (A)

Sol. Molality is independent of temperature and hence both assertion and reason are true.

2. Based upon VSEPR theory, match the shape (geometry) of the molecules in List-I with the molecules in List-II and select the most appropriate option

List-I	List-II
(Shape)	(Molecules)
(A) T-shaped	(I) XeF ₄
(B) Trigonal planar	(II) SF ₄
(C) Square planar	(III) ClF ₃
(D) See-saw	(IV) BF ₃

- (A) (A) – I, (B) – (II), (C) – (III), (D) – (IV)
 (B) (A) – (III), (B) – (IV), (C) – (I), (D) – (II)
 (C) (A) – (III), (B) – (IV), (C) – (II), (D) – (I)
 (D) (A) – (IV), (B) – (III), (C) – (I), (D) – (II)

Official Ans. by NTA (B)

Sol.

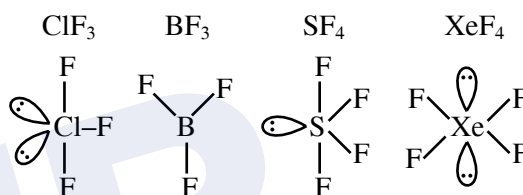

3. Match List-I with List-II

	List-I	List-II
(A)	Spontaneous process	(I) $\Delta H < 0$
(B)	Process with $\Delta P = 0$, $\Delta T = 0$	(II) $\Delta G_{T,P} < 0$
(C)	$\Delta H_{\text{reaction}}$	(III) Isothermal and isobaric process
(D)	Exothermic process	(IV) [Bond energies of molecules in reactants] - [Bond energies of product molecules]

Choose the correct answer from the options given below:

- (A) (A) – (III), (B) – (II), (C) – (IV), (D) – (I)
 (B) (A) – (II), (B) – (III), (C) – (IV), (D) – (I)
 (C) (A) – (II), (B) – (III), (C) – (I), (D) – (IV)
 (D) (A) – (II), (B) – (I), (C) – (III), (D) – (IV)

Official Ans. by NTA (B)

Sol. (A) For a spontaneous process $\Delta G_{T,P} < 0$
 (B) $\Delta P = 0 \rightarrow$ Isobaric process
 $\Delta T = 0 \rightarrow$ Isothermal process



(C) $\Delta H_{\text{reaction}} = (\Sigma \text{Bond energies of reactants}) - (\Sigma \text{bond energies of products})$

(D) $\Delta H < 0$ is for exothermic reaction

4. Match List-I with List-II

List-I	List-II
(A) Lyophilic colloid	(I) Liquid-liquid colloid
(B) Emulsion	(II) protective colloid
(C) Positively charged	(III) $\text{FeCl}_3 + \text{NaOH}$
(D) Negatively charged	(IV) $\text{FeCl}_3 + \text{hot water colloid}$

Choose the correct answer from the options given below:

- (A) (A) – (II), (B) – (I), (C) – (IV), (D) – (III)
 (B) (A) – (III), (B) – (I), (C) – (IV), (D) – (II)
 (C) (A) – (II), (B) – (I), (C) – (III), (D) – (IV)
 (D) (A) – (III), (B) – (II), (C) – (I), (D) – (IV)

Official Ans. by NTA (A)

Sol. (A) Protective colloids are lyophilic colloids
 (B) Emulsions are liquid in liquid colloidal solutions
 (C) $\text{FeCl}_3 + \text{hot water}$ forms positively charged colloidal solution of hydrated ferric oxide.
 (D) $\text{FeCl}_3 + \text{NaOH}$ forms negatively charged colloidal solution due to preferential adsorption of OH^- ions

5. Given below are two statements: one is labelled as Assertion (A) and the other is labelled as Reason(R)

Assertion (A): The ionic radii of O^{2-} and Mg^{2+} are same.

Reason (R) : Both O^{2-} and Mg^{2+} are isoelectronic species

In the light of the above statements, choose the correct answer from the options given below

(A) Both (A) and (R) are true and (R) is the correct explanation of (A)

(B) Both (A) and (R) are true but (R) is not the correct explanation of (A)

(C) (A) is true but (R) is false

(D) (A) is false but (R) is true

Official Ans. by NTA (D)

Sol. Ionic radius of O^{2-} is more than that of Mg^{2+}
 Both O^{2-} and Mg^{2+} are isoelectronic with 10 electrons

6. Match List-I with List-II

List-I	List-II
(A) Concentration of gold ore	(I) Aniline
(B) Leaching of alumina	(II) NaOH
(C) Froth stabiliser	(III) SO_2
(D) Blister copper	(IV) NaCN

Choose the correct answer from the options given below.

- (A) (A) – (IV), (B) – (III), (C) – (II), (D) – (I)
 (B) (A) – (IV), (B) – (II), (C) – (I), (D) – (III)
 (C) (A) – (III), (B) – (II), (C) – (I), (D) – (IV)
 (D) (A) – (II), (B) – (IV), (C) – (III), (D) – (I)

Official Ans. by NTA (B)

Sol. Gold is concentrated by cyanidation
 Leaching of alumina is done by NaOH
 Froth stabiliser is aniline
 Blister copper has condensed SO_2 on the surface

7. Addition of H_2SO_4 to BaO_2 produces:

- (A) BaO, SO_2 and H_2O (B) BaHSO_4 and O_2
 (C) BaSO_4 , H_2 and O_2 (D) BaSO_4 and H_2O_2

Official Ans. by NTA (D)

Sol. $\text{BaO}_2 + \text{H}_2\text{SO}_4 \rightarrow \text{BaSO}_4 + \text{H}_2\text{O}_2$
 This is a common method to prepare hydrogen peroxide

8. BeCl_2 reacts with LiAlH_4 to give

- (A) $\text{Be} + \text{Li}[\text{AlCl}_4] + \text{H}_2$
 (B) $\text{Be} + \text{AlH}_3 + \text{LiCl} + \text{HCl}$

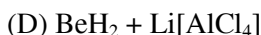

Official Ans. by NTA (C)

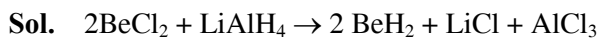

This is the method to prepare BeH_2

9. Match List-I with List-II

List-I

List-II

(Si-Compounds)

(Si-Polymeric/other products)



(I) Chain silicone

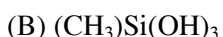

(II) Dimeric silicone

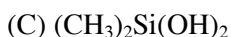

(III) Silane

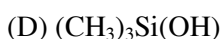

(IV) 2D - Silicone

Choose the correct answer from the options given below:

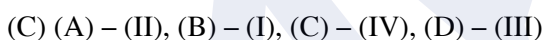
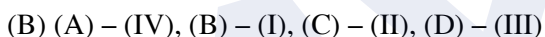
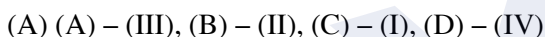

Official Ans. by NTA (D)

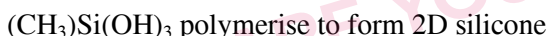
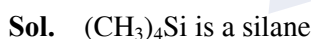

10. Heating white phosphorus with conc. NaOH solution gives mainly



Official Ans. by NTA (D)



11. Which of the following will have maximum stabilization due to crystal field?



Official Ans. by NTA (C)

Sol. Co^{3+} has maximum effective nuclear charge and CN^- is the strongest ligand in the given options

12. Given below are two statements:

Statement I: Classical smog occurs in cool humid climate. It is a reducing mixture of smoke, fog and sulphur dioxide

Statement II: Photochemical smog has components, ozone, nitric oxide, acrolein, formaldehyde, PAN etc.

In the light of above statements, choose the **most appropriate** answer from the options give below

(A) Both **Statement I** and **Statement II** are correct

(B) Both **Statement I** and **Statement II** are incorrect

(C) **Statement I** is correct but **statement II** is incorrect

(D) **Statement I** is incorrect but **Statement II** is correct

Official Ans. by NTA (A)

Sol. Classical smog occurs in cool humid climate. It is a reducing mixture of smoke, fog and sulphur dioxide

Photochemical smog has components, ozone, nitric oxide, acrolein, formaldehyde, PAN etc.

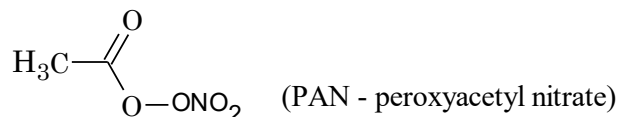

13. Which of the following is structure of a separating funnel?

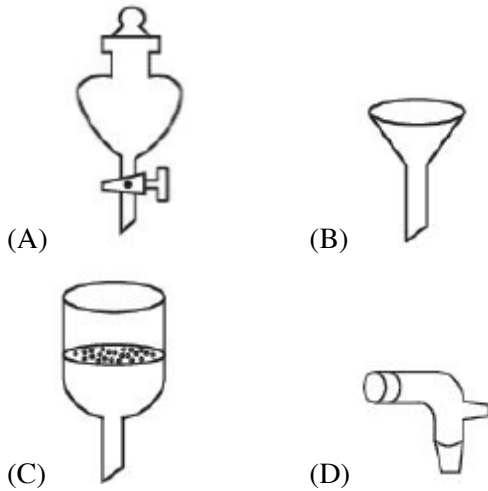

Official Ans. by NTA (A)

Sol. It is used to separate liquid-liquid mixture which is immiscible with different densities

14. 'A' and 'B' respectively are:

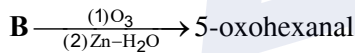
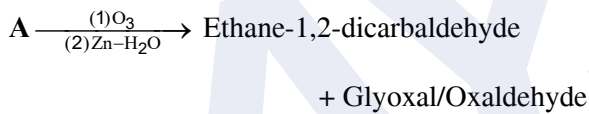

- (A) 1-methylcyclohex-1,3-diene & cyclopentene
(B) Cyclohex-1,3-diene & cyclopentene
(C) 1-methylcyclohex-1,4-diene & 1-methylcyclopent-1-ene
(D) Cyclohex-1,3-diene & 1-methylcyclopent-1-ene

Official Ans. by NTA (D)

Sol.

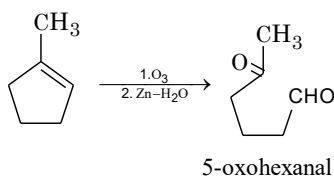
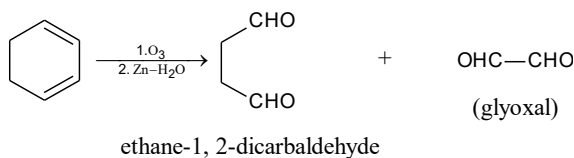

15. The major product of the following reaction is:

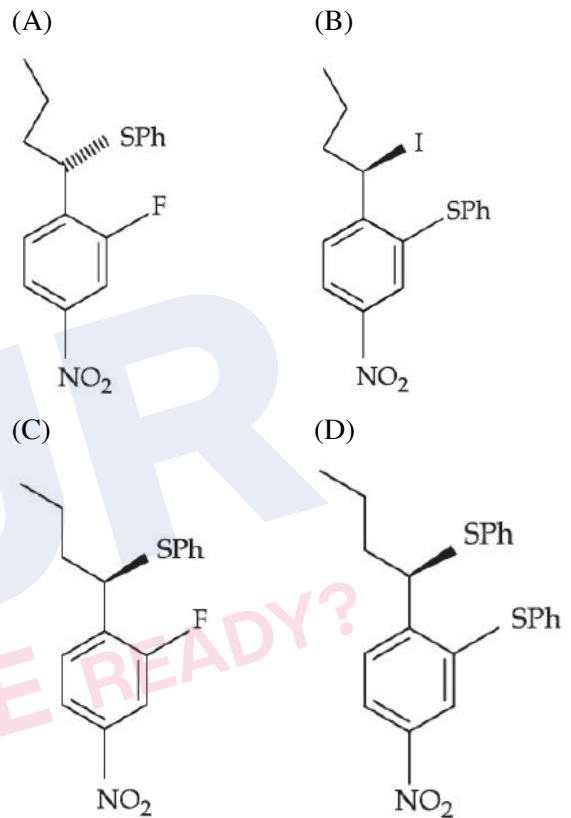
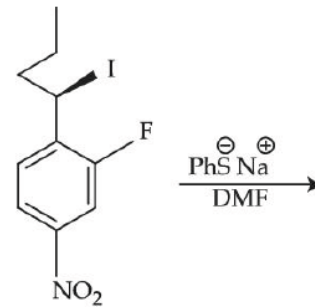

Official Ans. by NTA (A)

Sol.

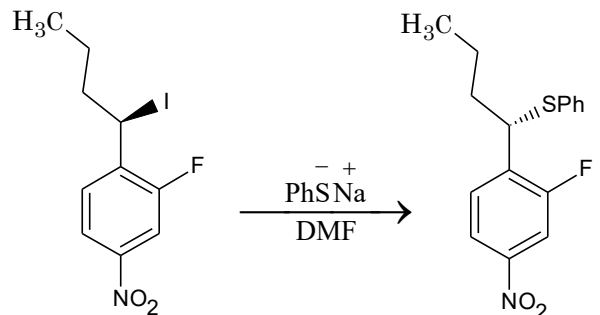

It is bimolecular nucleophilic substitution (S_{N}^2) which occur at benzylic carbon by inversion in configuration. This reaction cannot undergo substitution at benzene ring

16. Which of the following reactions will yield benzaldehyde as a product?

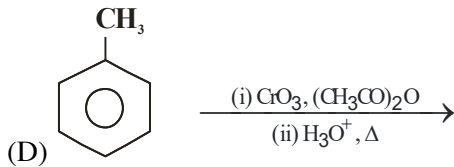
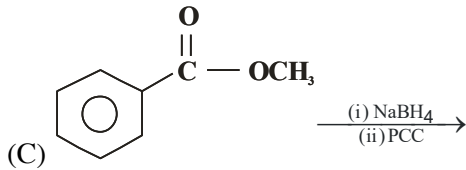
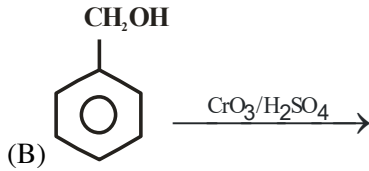
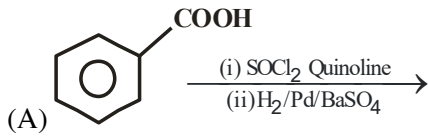

- (A) (B) and (C) (B) (C) and (D)
 (C) (A) and (D) (D) (A) and (C)

Official Ans. by NTA (C)

Sol.

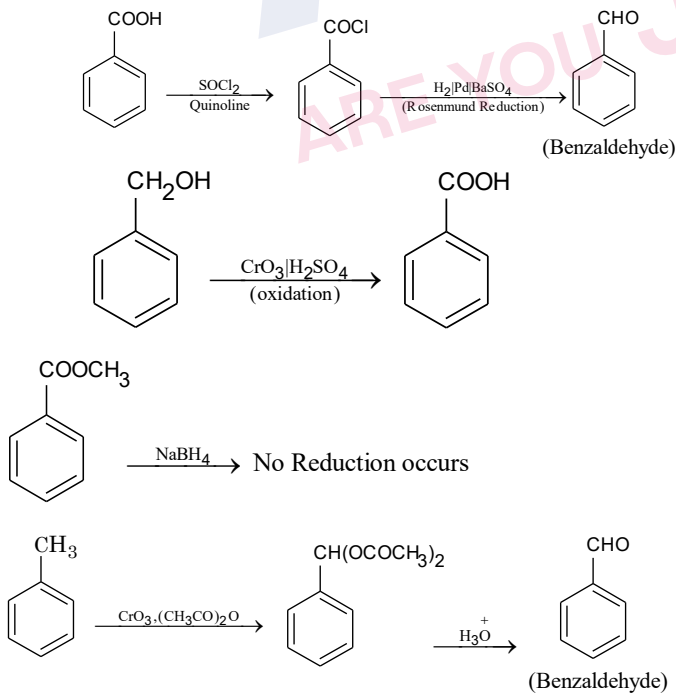

17. Given below are two statements:

Statements-I : In Hofmann degradation reaction, the migration of only an alkyl group takes place from carbonyl carbon of the amide to the nitrogen atom.

Statement-II : The group is migrated in Hofmann degradation reaction to electron deficient atom.

In the light of the above statement, choose the **most appropriate** answer from the options given below:

- (A) Both **Statement-I** and **Statement-II** are correct
 (B) Both **Statement-I** and **Statement-II** are incorrect
 (C) **Statement-I** is correct but **Statement-II** is incorrect
 (D) **Statement-I** is incorrect but **Statement-II** is correct

Official Ans. by NTA (D)

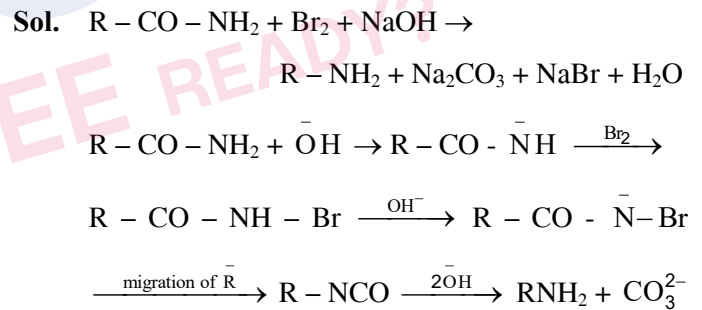

In this reaction of alkyl as well as aryl group can migrate to electron deficient nitrogen atom.

18. Match List-I with List-II

- | List-I | List-II |
|------------------|-----------------------------------|
| (Polymer) | (Used in) |
| (A) Bakelite | (I) Radio and television Cabinets |
| (B) Glyptal | (II) Electrical switches |
| (C) PVC | (III) Paints and Lacquers |
| (D) Polystyrene | (IV) Water pipes |

Choose the correct answer from the options given below:

- (A) (A) – (II), (B) – (III), (C) – (IV), (D) – (I)
 (B) (A) – (I), (B) – (II), (C) – (III), (D) – (IV)
 (C) (A) – (IV), (B) – (III), (C) – (II), (D) – (I)
 (D) (A) – (II), (B) – (III), (C) – (I), (D) – (IV)

Official Ans. by NTA (A)

Sol. Bakelite- It is thermosetting polymer used for making electrical switches.

Glyptal – manufacture of paints and lacquers

PVC – manufacture of water pipes, rain coats, hand bags

Polystyrene – manufacture of radio and television cabinets

19. L-isomer of a compound 'A' ($C_4H_8O_4$) gives a positive test with $[Ag(NH_3)_2]^+$. Treatment of 'A' with acetic anhydride yield triacetate derivative. Compound 'A' produces an optically active compound (B) and an optically inactive compound (C) on treatment with bromine water and HNO_3 respectively, compound (A) is:

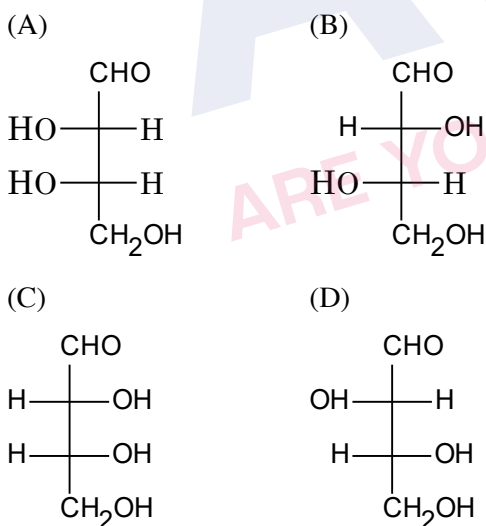

Official Ans. by NTA (A)

Sol.

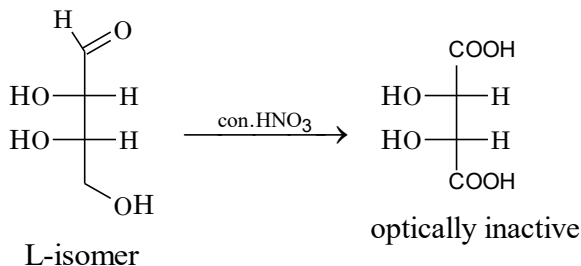
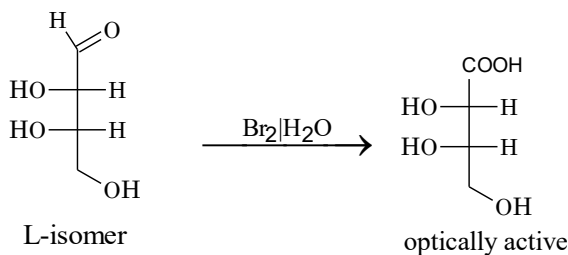

20. Match List-I with List-II

List-I

(A)

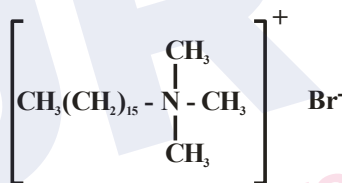

(B)

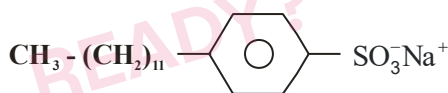

(C) $C_{17}H_{35}COO^-Na^+ + Na_2CO_3 + \text{Rosinate}$

(D) $CH_3(\text{CH}_2)_{16}COO(\text{CH}_2\text{CH}_2\text{O})_n\text{CH}_2\text{CH}_2\text{OH}$

List-II

(I) Dishwashing powder

(II) Toothpaste

(III) Laundry soap

(IV) Hair conditioner

(A) (A) – (III), (B) – (II), (C) – (IV), (D) – (I)

(B) (A) – (IV), (B) – (II), (C) – (III), (D) – (I)

(C) (A) – (IV), (B) – (III), (C) – (II), (D) – (I)

(D) (A) – (III), (B) – (IV), (C) – (I), (D) – (II)

Official Ans. by NTA (B)

Sol. (A) $[\text{CH}_3(\text{CH}_2)_{15} - \text{N}(\text{CH}_3)_3]^+ \text{Br}^-$
 is cationic detergents used in hair conditioner

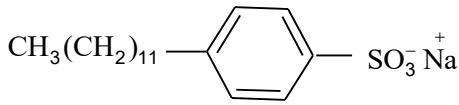

(B)

Is anionic detergent used in tooth pastes

(C) $\text{C}_{17}\text{H}_{35}\text{COO}^- \text{Na}^+ + \text{Na}_2\text{CO}_3 + \text{Rosinate}$ is used as laundry soap

(D) $\text{CH}_3(\text{CH}_2)_{16}\text{COO}(\text{CH}_2\text{CH}_2\text{O})_N\text{CH}_2\text{CH}_2\text{OH}$ is non-ionic detergents formed from stearic acid and poly ethylene glycol used as liquid dishwashing detergents

SECTION-B

1. Metal deficiency defect is shown by $\text{Fe}_{0.93}\text{O}$. In the crystal, some Fe^{2+} cations are missing and loss of positive charge is compensated by the presence of Fe^{3+} ions. The percentage of Fe^{2+} ions in the $\text{Fe}_{0.93}\text{O}$ crystals is _____. (Nearest integer)

Official Ans. by NTA (85)

Sol. In $\text{Fe}_{0.93}\text{O}$ for every 93 Fe ions 14 are Fe^{+3} and $(93 - 14) = 79$ are Fe^{+2} ions
 $\therefore \% \text{Fe}^{+2} = \frac{79}{93} \times 100 = 84.9\%$
 \therefore nearest integer = 85%

2. If the uncertainty in velocity and position of a minute particle in space are, $2.4 \times 10^{-26} \text{ (ms}^{-1}\text{)}$ and 10^{-7} (m) respectively. The mass of the particle in g is _____ (Nearest integer)

(Given : $h = 6.626 \times 10^{-34} \text{ Js}$)

Official Ans. by NTA (22)

Sol. $\Delta V = 2.4 \times 10^{-26} \text{ ms}^{-1}$
 $\Delta x = 10^{-7} \text{ m}$
 $\therefore \Delta p \cdot \Delta x = \frac{h}{4\pi}$

$$\therefore m \Delta V \cdot \Delta x = \frac{h}{4\pi}$$

$$\Rightarrow m \times 2.4 \times 10^{-26} \times 10^{-7} = \frac{6.626 \times 10^{-34}}{4 \times \pi}$$

$$m = \frac{6.626}{9.6 \times \pi} \times 10^{-1}$$

$$m = 0.02198 \text{ kg}$$

$$m = 21.98 \text{ gm}$$

nearest integer = 22

3. 2g of a non-volatile non-electrolyte solute is dissolved in 200 g of two different solvents A and B whose ebullioscopic constants are in the ratio of 1 : 8. The elevation in boiling points of A and B are in the ratio $\frac{x}{y}$ ($x : y$). The value of y is _____ (Nearest integer)

Official Ans. by NTA (8)

Sol. Given : $\frac{(K_b)_A}{(K_b)_B} = \frac{1}{8}$

$$\therefore \frac{(\Delta T_B)_A}{(\Delta T_B)_B} = \frac{(K_b)_A \cdot m}{(K_b)_B \cdot m} = \frac{1}{8} = \frac{x}{y}$$

$$\therefore \frac{x}{y} = \frac{1}{8}$$

$$\therefore y = 8 \text{ (nearest integer)}$$

4. $2\text{NOCl(g)} \rightleftharpoons 2\text{NO(g)} + \text{Cl}_2\text{(g)}$

In an experiment, 2.0 moles of NOCl was placed in a one-litre flask and the concentration of NO after equilibrium established, was found to be 0.4 mol/L. The equilibrium constant at 30°C is _____ $\times 10^{-4}$.

Official Ans. by NTA (125)

Sol. $2\text{NOCl(g)} \rightleftharpoons 2\text{NO(g)} + \text{Cl}_2\text{(g)}$

t=0	2M	-	-
t=t _{eq}	(2-x)M	x M	$\frac{x}{2}$ M

$$\therefore x = 0.4 \text{ M}$$

$$\therefore [\text{NOCl}]_{\text{eq}} = 1.6 \text{ M}$$

$$[\text{NO}]_{\text{eq}} = 0.4 \text{ M}$$

$$[\text{Cl}_2]_{\text{eq}} = 0.2 \text{ M}$$

$$\Rightarrow K_c = \frac{[\text{NO}]^2[\text{Cl}_2]}{[\text{NOCl}]^2} = \frac{[0.4]^2[0.2]}{[1.6]^2}$$

$$K_c = \frac{32}{2.56} \times 10^{-3}$$

$$K_c = 12.5 \times 10^{-3}$$

$$K_c = 125 \times 10^{-4}$$

Integer answer is 125

5. The limiting molar conductivities of NaI, NaNO₃ and AgNO₃ are 12.7, 12.0 and 13.3 mS m² mol⁻¹, respectively (all at 25°C). The limiting molar conductivity of AgI at this temperature is _____ mS m² mol⁻¹

Official Ans. by NTA (14)

Sol. Given

$$(1) \lambda_m^\infty (\text{NaI}) = 12.7 \text{ mS m}^2 \text{ mol}^{-1}$$

$$(2) \lambda_m^\infty (\text{NaNO}_3) = 12.0 \text{ mS m}^2 \text{ mol}^{-1}$$

$$(3) \lambda_m^\infty (\text{AgNO}_3) = 13.3 \text{ mS m}^2 \text{ mol}^{-1}$$

$$\lambda_m^\infty (\text{Ag I}) = (1) + (3) - (2)$$

$$= 12.7 + 13.3 - 12.0$$

$$= 26.0 - 12.0$$

$$\lambda_m^\infty (\text{Ag I}) = 14.0$$

6. The rate constant for a first order reaction is given by the following equation:

$$\ln k = 33.24 - \frac{2.0 \times 10^4 \text{ K}}{T}$$

The Activation energy for the reaction is given by _____ kJ mol⁻¹. (In Nearest integer)

(Given: R = 8.3 J K⁻¹ mol⁻¹)

Official Ans. by NTA (166)

Sol. $\ln k = \ln A - \frac{E_A}{RT}$

Given: $\ln k = 33.24 - \frac{2.0 \times 10^4}{T}$

\therefore on comparing $\frac{E_A}{R} = 2.0 \times 10^4$

$\therefore E_A = 2.0 \times 10^4 \times R$

$\Rightarrow E_A = 2.0 \times 10^4 \times 8.3 \text{ J}$

$\Rightarrow E_A = 16.6 \times 10^4 \text{ J} = 166 \text{ kJ}$

7. The number of statement(s) correct from the following for copper (at no. 29) is/are _____
- (A) Cu(II) complexes are always paramagnetic
(B) Cu(I) complexes are generally colourless
(C) Cu(I) is easily oxidized
(D) In Fehling solution, the active reagent has Cu(I)

Official Ans. by NTA (3)

Sol. A,B,C are correct and D is incorrect because Fehling solution has Cu(II)

8. Acidified potassium permanganate solution oxidises oxalic acid. The spin-only magnetic moment of the manganese product formed from the above reaction is _____ B.M. (Nearest Integer)

Official Ans. by NTA (6)

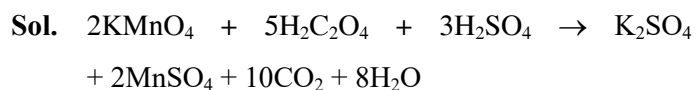

Mn²⁺ has 5 unpaired electrons therefore the magnetic moment is $\sqrt{35}$ BM

9. Two elements A and B which form 0.15 moles of A_2B and AB_3 type compounds. If both A_2B and AB_3 weigh equally, then the atomic weight of A is _____ times of atomic weight of B.

Official Ans. by NTA (2)

Sol. Given : Molar mass of $A_2B = AB_3$

$$\therefore (2A + B) = (A + 3B) \begin{bmatrix} A \rightarrow \text{Atomic wt. of A} \\ B \rightarrow \text{Atomic wt. of B} \end{bmatrix}$$

$$\Rightarrow A = 2B$$

\therefore atomic wt. of A is 2 times of atomic wt. of B

Integer answer is 2

10. Total number of possible stereoisomers of dimethyl cyclopentane is _____

Official Ans. by NTA (6)

Sol. Dimethyl cyclopentane

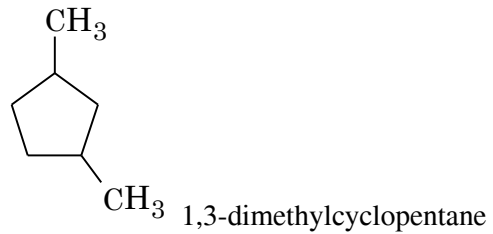
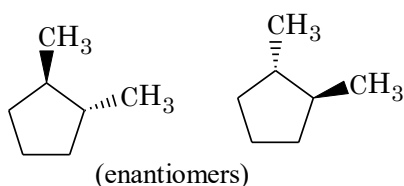
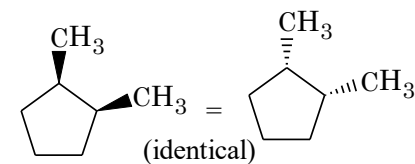
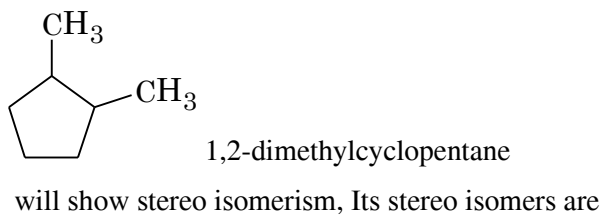
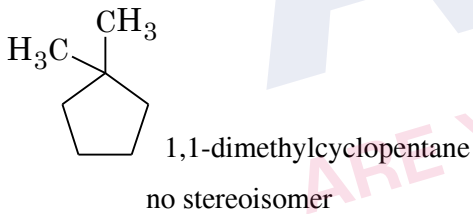

will show stereo isomerism, Its stereo isomers are

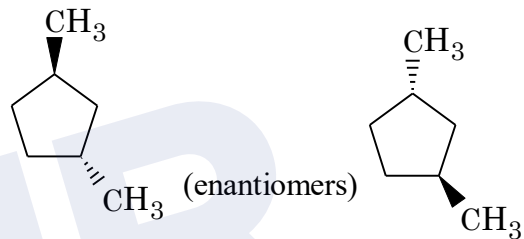
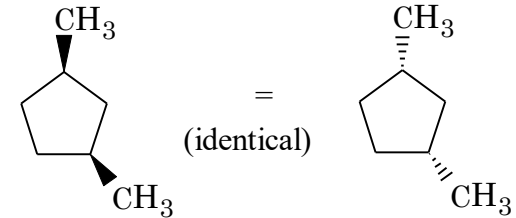

FINAL JEE-MAIN EXAMINATION – JUNE, 2022

(Held On Monday 27th June, 2022)

TIME : 9 : 00 AM to 12 : 00 PM

MATHEMATICS

TEST PAPER WITH SOLUTION

SECTION-A

1. The area of the polygon, whose vertices are the non-real roots of the equation $\bar{z} = iz^2$ is :

- (A) $\frac{3\sqrt{3}}{4}$ (B) $\frac{3\sqrt{3}}{2}$
(C) $\frac{3}{2}$ (D) $\frac{3}{4}$

Official Ans. by NTA (A)

Sol. \Rightarrow Let $z = x + iy$, $x, y \in \mathbb{R}$

Now $\bar{z} = iz^2$

then $x - iy = i(x^2 - y^2 + 2xyi)$

$x - iy = i(x^2 - y^2) - 2xy$

$\Rightarrow x = -2xy$ & $-y = x^2 - y^2$

$\Rightarrow x(1 + 2y) = 0$

$x = 0$ or $y = -\frac{1}{2}$

Put $x = 0$ in $-y = x^2 - y^2$

We get $y = y^2$

$\Rightarrow y = 0, 1$

Similarly

Put $y = -\frac{1}{2}$ in $-y = x^2 - y^2$

$\Rightarrow \frac{1}{2} = x^2 - \frac{1}{4}$

$\Rightarrow x^2 = \frac{3}{4}$

$x = \pm \frac{\sqrt{3}}{2}$

$z = \left(0, i, \frac{\sqrt{3}}{2} - \frac{1}{2}i, -\frac{\sqrt{3}}{2} - \frac{1}{2}i \right)$

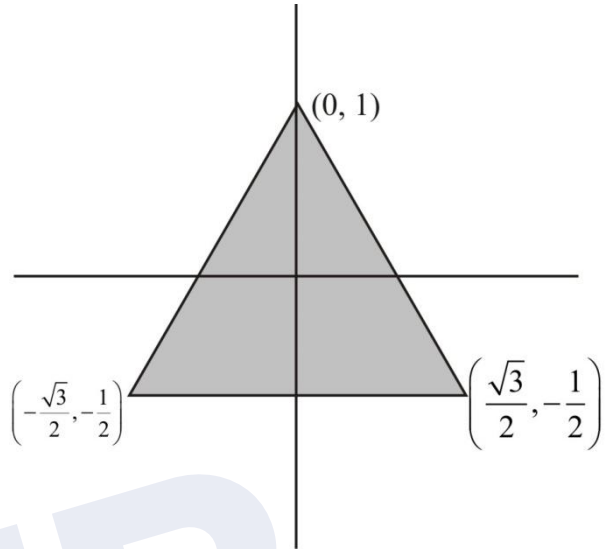

$$\begin{aligned} \text{Area} &= \frac{1}{2} \cdot (\sqrt{3}) \left(\frac{3}{2}\right) \\ &= \frac{3\sqrt{3}}{4} \end{aligned}$$

2. Let the system of linear equations $x + 2y + z = 2$, $\alpha x + 3y - z = \alpha$, $-\alpha x + y + 2z = -\alpha$ be inconsistent. Then α is equal to :

- (A) $\frac{5}{2}$ (B) $-\frac{5}{2}$
(C) $\frac{7}{2}$ (D) $-\frac{7}{2}$

Official Ans. by NTA (D)

Sol. $\Delta = \begin{vmatrix} 1 & 2 & 1 \\ 2 & 3 & -1 \\ -2 & 1 & 2 \end{vmatrix}$

$$\begin{aligned} &= (6 + y) - 2((2\alpha - \alpha) + 1(\alpha + 3\alpha)) \\ &= 7 - 2\alpha + 4\alpha \\ &= 7 + 2\alpha \\ \Delta = 0 &\Rightarrow \alpha = -\frac{7}{2} \end{aligned}$$

$$\Delta_1 = \begin{vmatrix} 2 & 2 & 1 \\ \alpha & 3 & -1 \\ -\alpha & 1 & 2 \end{vmatrix}$$

$$= 14 + 2\alpha$$

$$\alpha = -x_2 = 7$$

$$\Delta_1 \neq 0$$

3. If $x = \sum_{n=0}^{\infty} a^n, y = \sum_{n=0}^{\infty} b^n, z = \sum_{n=0}^{\infty} c^n$, where a, b, c

are in A.P. and $|a| < 1, |b| < 1, |c| < 1, abc \neq 0$, then

(A) x, y, z are in A.P.

(B) x, y, z are in G.P.

(C) $\frac{1}{x}, \frac{1}{y}, \frac{1}{z}$ are in A.P.

(D) $\frac{1}{x} + \frac{1}{y} + \frac{1}{z} = 1 - (a + b + c)$

Official Ans. by NTA (C)

Sol. $x = 1 + a + a^2 = \dots$

$$x = \frac{1}{1-a} \Rightarrow a = 1 - \frac{1}{x}$$

$$y = \frac{1}{1-b} \Rightarrow b = 1 - \frac{1}{y}$$

$$z = \frac{1}{1-c} \Rightarrow c = 1 - \frac{1}{z}$$

a, b, c are in A.P.

$$\Rightarrow 1 - \frac{1}{x}, 1 - \frac{1}{y}, 1 - \frac{1}{z} \text{ are in A.P.}$$

$$\Rightarrow -\frac{1}{x}, -\frac{1}{y}, -\frac{1}{z} \text{ are in A.P.}$$

$$\Rightarrow \frac{1}{x}, \frac{1}{y}, \frac{1}{z} \text{ are in A.P.}$$

4. Let $\frac{dy}{dx} = \frac{ax - by + a}{bx + cy + a}$, where a, b, c are constants,

represent a circle passing through the point (2, 5).

Then the shortest distance of the point (11, 6) from this circle is :

(A) 10 (B) 8

(C) 7 (D) 5

Official Ans. by NTA (B)

Sol. Let equation of circle is

$$x^2 + y^2 + 2gx + 2fy + c = 0$$

$$\Rightarrow \frac{dy}{dx} = \frac{-(2x + 2g)}{(2y + 2f)}$$

$$\text{Comparing with } \frac{dy}{dx} = \frac{ax - by + a}{bx + cy + a}$$

$$\Rightarrow b = 0, a = -2, c = 2$$

$$\Rightarrow -2g = -2 \Rightarrow g = 1 \quad 2f = -2$$

$$f = -1$$

Now circle will be

$$x^2 + y^2 + 2x - 2y + c = 0$$

its passes through (2, 5)

which will give $c = -23$

so circle will be $x^2 + y^2 + 2x - 2y - 23 = 0$

centre $C = (-1, 1)$

and radius 5

Now P is (11, 6)

So minimum distance of P from circle will be

$$= \sqrt{(11+1)^2 + (6-1)^2} - 5$$

$$= 13 - 5$$

$$= 8$$

5. Let a be an integer such that $\lim_{x \rightarrow 7} \frac{18 - [1-x]}{[x-3a]}$

exists, where [t] is greatest integer $\leq t$. Then a is equal to :

(A) -6 (B) -2

(C) 2 (D) 6

Official Ans. by NTA (A)

Sol. $\lim_{x \rightarrow 7} \frac{18 - [1 - x]}{[x] - 3a}$

L.H.L. $\lim_{x \rightarrow 7^-} \frac{18 - [1 - x]}{[x] - 3a}$

$$= \frac{18 - (-6)}{6 - 3a}$$

$$= \frac{24}{6 - 3a}$$

R.H.L. $\lim_{x \rightarrow 7^+} \frac{18 - [1 - x]}{[x] - 3a}$

$$= \frac{18 - (-7)}{7 - 3a}$$

$$= \frac{25}{7 - 3a}$$

Now L.H.L. = R.H.L.

$$\frac{24}{6 - 3a} = \frac{25}{7 - 3a}$$

$$\Rightarrow 168 - 72a = 150 - 75a$$

$$\Rightarrow 18 = -3a$$

$$\Rightarrow a = -6$$

6. The number of distinct real roots of $x^4 - 4x + 1 = 0$ is :

- (A) 4 (B) 2
 (C) 1 (D) 0

Official Ans. by NTA (B)

Sol. Let $f(x) = x^4 - 4x + 1$

$$f'(x) = 4x^3 - 4$$

$$f'(x) = 0 \Rightarrow x = 1$$

$x = 1$ is point of minima.

$$f(1) = -2$$

$$f(0) = 1$$

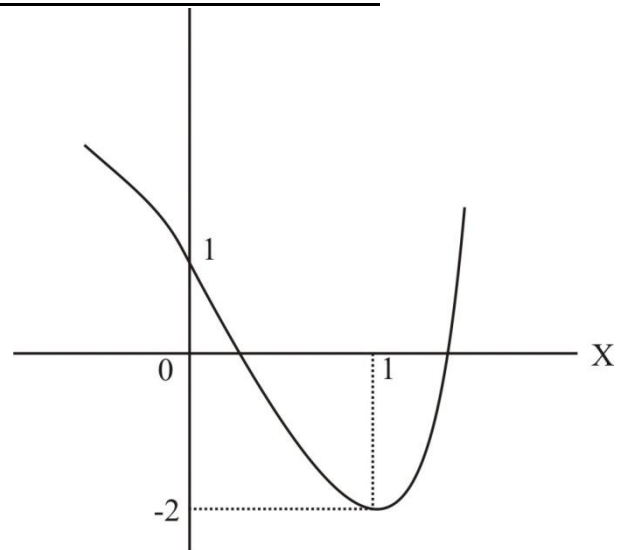

Hence 2 solutions.

7. The lengths of the sides of a triangle are $10 + x^2$, $10 + x^2$ and $20 - 2x^2$. If for $x = k$, the area of the triangle is maximum, then $3k^2$ is equal to :

- (A) 5 (B) 8
 (C) 10 (D) 12

Official Ans. by NTA (C)

Sol.

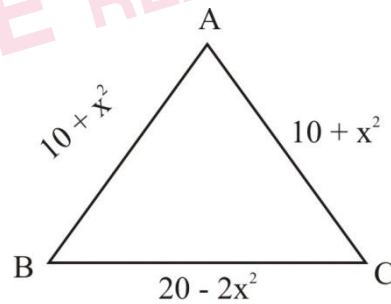

$$a = 20 - 2x^2, b = 10 + x^2, c = 10 + x^2$$

$$= \frac{a + b + c}{2}$$

$$= 20$$

$$\Delta = \sqrt{s(s-a)(s-b)(s-c)}$$

$$= \sqrt{20(2x^2)(10-x^2)(10-x^2)}$$

$$= 2\sqrt{10} \sqrt{x^2(10-x^2)^2}$$

$$= 2\sqrt{10} |x(10-x^2)|$$

$$= 2\sqrt{10} |10x - x^3|$$

$$S = 10x - x^3$$

$$\frac{ds}{dx} = 10 - 3x^2$$

$$\frac{ds}{dx} = 0 \Rightarrow x^2 = \frac{10}{3}$$

$$3x^2 = 10$$

8. If $\cos^{-1}\left(\frac{y}{2}\right) = \log_e\left(\frac{x}{5}\right)^5$, $|y| < 2$, then :

(A) $x^2 y'' + xy' - 25y = 0$

(B) $x^2 y'' - xy' - 25y = 0$

(C) $x^2 y'' - xy' + 25y = 0$

(D) $x^2 y'' + xy' + 25y = 0$

Official Ans. by NTA (D)

Sol. $\cos^{-1}\left(\frac{y}{2}\right) = \log_e\left(\frac{x}{5}\right)^5$

$$\cos^{-1}\left(\frac{y}{2}\right) = 5 \log_e\left(\frac{x}{5}\right)$$

$$\frac{-1}{\sqrt{1-\frac{y^2}{4}}} \cdot \frac{y'}{2} = 5 \cdot \frac{1}{x} \times \frac{1}{5}$$

$$\Rightarrow \frac{-y'}{\sqrt{4-y^2}} = \frac{5}{x}$$

$$-xy' = 5\sqrt{4-y^2}$$

$$-xy'' - y' = 5 \cdot \frac{1}{2\sqrt{4-y^2}} (-2y y')$$

$$\Rightarrow xy'' + y' = \frac{5y' \cdot y}{\sqrt{4-y^2}}$$

$$xy'' + y' = 5 \cdot \left(\frac{-5}{x}\right) y$$

$$x^2 y'' + xy' = -25y$$

9. $\int \frac{(x^2+1)e^x}{(x+1)^2} dx = f(x)e^x + C$, Where C is a

constant, then $\frac{d^3 f}{dx^3}$ at $x = 1$ is equal to :

(A) $-\frac{3}{4}$ (B) $\frac{3}{4}$

(C) $-\frac{3}{2}$ (D) $\frac{3}{2}$

Official Ans. by NTA (B)

Sol. $\int \left(\frac{x^2+1}{(x+1)^2}\right) e^x \cdot dx$

$$= \int \left(\frac{x^2-1+2}{(x+1)^2}\right) e^x dx$$

$$= \int \left(\frac{x-1}{x+1} + \frac{2}{(x+1)^2}\right) e^x dx$$

$$= \int (f(x) + f'(x)) e^x dx$$

$$= f(x) e^x + c$$

Where $f(x) = \frac{x-1}{x+1}$

$$f'(x) = \frac{2}{(x+1)^2}$$

$$f''(x) = \frac{-4}{(x+1)^3}$$

$$= \frac{12}{(x+1)^4}$$

$$f''(1) = \frac{12}{16}$$

$$= \frac{3}{4}$$

10. The value of the integral $\int_{-2}^2 \frac{|x^3 + x|}{(e^{|x|} + 1)} dx$ is equal

to :

- (A) $5e^2$ (B) $3e^2$
 (C) 4 (D) 6

Official Ans. by NTA (D)

Sol. $f(x) = \frac{|x^3 + x|}{(e^{|x|} + 1)} dx$

$$\int_{-2}^2 f(x) dx = \int_0^2 (f(x) + f(-x)) dx$$

$$= \int_0^2 \left(\frac{|x^3 + x|}{(e^{|x|} + 1)} + \frac{|-x^3 - x|}{(e^{-x|-x|} + 1)} \right) dx$$

$$= \int_0^2 \left(\frac{|x^3 + x|}{(e^{|x|} + 1)} + \frac{|x^3 + x|}{(e^{-x|-x|} + 1)} \right) dx$$

$$= \int_0^2 \left(\frac{x^3 + x}{(e^{x^2} + 1)} + \frac{x^3 + x}{(e^{-x^2} + 1)} \right) dx$$

$$I = \int_0^2 \left(\frac{x^3 + x}{1 + e^{x^2}} + \frac{e^{x^2}(x^3 + x)}{1 + e^{x^2}} \right) dx$$

$$= \int_0^2 (x^3 + x) dx$$

$$= \left[\frac{x^4}{4} + \frac{x^2}{2} \right]_0^2$$

$$= 4 + 2 = 6$$

11. If $\frac{dy}{dx} + \frac{2^{x-y}(2^y - 1)}{2^x - 1} = 0, x, y > 0, y(1) = 1$, then

$y(2)$ is equal to :

- (A) $2 + \log_2 3$ (B) $2 + \log_2 2$
 (C) $2 - \log_2 3$ (D) $2 - \log_2 3$

Official Ans. by NTA (D)

Sol. $\frac{dy}{dx} + \frac{2^{x-y}(2^y - 1)}{2^x - 1} = 0,$

$$x, y > 0, y(1) = 1, y(2) = ?$$

$$\frac{dy}{dx} = -\frac{2^x(2^y - 1)}{2^y(2^x - 1)}$$

$$\int \frac{2^y}{2^y - 1} dy = -\int \frac{2^x}{2^x - 1} dx$$

$$\frac{1}{\ln 2} \int \frac{2^y \ln 2}{2^y - 1} dy = -\frac{1}{\ln 2} \int \frac{2^x \ln 2}{2^x - 1} dx$$

$$\frac{1}{\ln 2} \ln|2^y - 1| = \frac{-1}{\ln 2} \ln|2^x - 1| + C$$

$$\text{At } x = 1, y = 1$$

Putting this values in above relation we get $C = 0$

$$\ln|2^y - 1| + \ln|2^x - 1| = 0$$

$$(2^x - 1)(2^y - 1) = 1$$

$$2^y - 1 = \frac{1}{2^x - 1}$$

$$\text{At } x = 2$$

$$2^y = \frac{1}{3} + 1 = \frac{4}{3}$$

$$y = \log_2 \frac{4}{3} = \log_2 4 - \log_2 3 = 2 - \log_2 3$$

12. In an isosceles triangle ABC, the vertex A is (6, 1) and the equation of the base BC is $2x + y = 4$. Let the point B lie on the line $x + 3y = 7$. If (α, β) is the centroid ΔABC , then $15(\alpha + \beta)$ is equal to :

- (A) 39 (B) 41
 (C) 51 (D) 63

Official Ans. by NTA (C)

Sol.

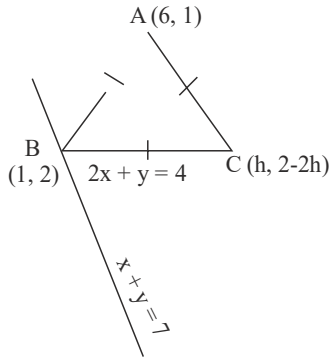

Point B (1, 2)

Now let C be (h, 4 - 2h)

(As C lies on $2x + y = 4$)

$\therefore \Delta$ is isosceles with base BC

$\therefore AB = AC$

$$\sqrt{25+1} = \sqrt{(6-h)^2 + (2h-3)^2}$$

$$\sqrt{26} = \sqrt{36+h^2-12h+4h^2+9-12h}$$

$$26 = 5h^2 - 24h + 45 \Rightarrow 5h^2 - 24h + 19 = 0$$

$$\Rightarrow 5h^2 - 5h - 19h + 19 = 0$$

$$h = \frac{19}{5} \text{ or } h = 1$$

Thus $C\left(\frac{19}{5}, \frac{-18}{5}\right)$

$$\text{Centroid} \left(\frac{6+1+\frac{19}{5}}{3}, \frac{1+2-\frac{18}{5}}{3} \right)$$

$$\left(\frac{35+19}{15}, \frac{15-18}{15} \right)$$

$$\left(\frac{54}{15}, \frac{-3}{15} \right)$$

$$\alpha = \frac{54}{15}; \beta = \frac{-3}{15}$$

$$15(\alpha + \beta) = 51$$

13. Let the eccentricity of an ellipse

$$\frac{x^2}{a^2} + \frac{y^2}{b^2} = 1, a > b, \text{ be } \frac{1}{4}. \text{ If this ellipse passes}$$

through the point $\left(-4\sqrt{\frac{2}{5}}, 3\right)$, then $a^2 + b^2$ is equal

to :

(A) 29

(B) 31

(C) 32

(D) 34

Official Ans. by NTA (B)

Sol. $\frac{x^2}{a^2} + \frac{y^2}{b^2} = 1 \quad a > b$

$$e^2 = 1 - \frac{b^2}{a^2}$$

$$\frac{1}{16} = 1 - \frac{b^2}{a^2}$$

$$\frac{b^2}{a^2} = 1 - \frac{1}{16} = \frac{15}{16} \Rightarrow b^2 = \frac{15}{16} a^2$$

$$\frac{x^2}{a^2} + \frac{y^2}{b^2} = 1$$

$$\frac{16 \times \frac{2}{5}}{a^2} + \frac{9}{b^2} = 1$$

$$\frac{32}{5a^2} + \frac{9}{b^2} = 1$$

$$\frac{32}{5a^2} + \frac{9}{\frac{15}{16}a^2} = 1$$

$$\frac{80}{5a^2} = 1$$

$$16 = a^2$$

$$b^2 = 15$$

14. If two straight lines whose direction cosines are given by the relations $l + m - n = 0$, $3l^2 + m^2 + cnl = 0$ are parallel, then the positive value of c is :

- (A) 6 (B) 4
 (C) 3 (D) 2

Official Ans. by NTA (A)

Sol. $l + m - n = 0$

$$3l^2 + m^2 + cl(1 + m) = 0$$

$$n = 1 + m$$

$$3l^2 + m^2 + cl^2 + clm = 0$$

$$(3 + c)l^2 + clm + m^2 = 0$$

$$(3 + c)\left(\frac{l}{m}\right)^2 + c\left(\frac{l}{m}\right) + 1 = 0 \dots (1)$$

\therefore lines are parallel.

Roots of (1) must be equal

$$\Rightarrow D = 0$$

$$c^2 - 4(3 + c) = 0$$

$$c^2 - 4c - 12 = 0$$

$$(c - 6)(c + 2) = 0$$

$$c = 6 \text{ or } c = -2$$

$$+ve \text{ value of } c = 6$$

15. Let $\vec{a} = \hat{i} + \hat{j} - \hat{k}$ and $\vec{c} = 2\hat{i} - 3\hat{j} + 2\hat{k}$. Then the number of vectors \vec{b} such that $\vec{b} \times \vec{c} = \vec{a}$ and $|\vec{b}| \in \{1, 2, \dots, 10\}$ is :

- (A) 0 (B) 1
 (C) 2 (D) 3

Official Ans. by NTA (A)

Sol. $\vec{a} = i + j - k$

$$\vec{c} = 2i - 3j + 2k$$

$$\vec{b} \times \vec{c} = \vec{a}$$

$$|\vec{b}| \in \{1, 2, \dots, 10\}$$

$$\therefore \vec{b} \times \vec{c} = \vec{a}$$

$\Rightarrow \vec{a}$ is perpendicular to \vec{b} as well as \vec{a} is perpendicular to \vec{c}

$$\text{Now } \vec{a} \cdot \vec{c} = 2 - 3 - 2 = -3 \neq 0$$

This $\vec{b} \times \vec{c} = \vec{a}$ is not possible.

$$\text{No. of vectors } \vec{b} = 0$$

16. Five numbers x_1, x_2, x_3, x_4, x_5 are randomly selected from the numbers $1, 2, 3, \dots, 18$ and are arranged in the increasing order ($x_1 < x_2 < x_3 < x_4 < x_5$). The probability that $x_2 = 7$ and $x_4 = 11$ is :

- (A) $\frac{1}{136}$ (B) $\frac{1}{72}$
 (C) $\frac{1}{68}$ (D) $\frac{1}{34}$

Official Ans. by NTA (C)

Sol. No. of ways to select and arrange x_1, x_2, x_3, x_4, x_5 from $1, 2, 3, \dots, 18$

$$n(S) = {}^{18}C_5$$

$$x_1 \quad (x_2) \quad x_3 \quad (x_4) \quad x_5$$

$$7 \quad 11$$

$$n(E) = {}^6C_1 \times {}^3C_1 \times {}^7C_1$$

$$P(E) = \frac{6 \times 3 \times 7}{{}^{18}C_5}$$

$$\frac{1}{17 \times 4} = \frac{1}{68}$$

17. Let X be a random variable having binomial distribution $B(7, p)$. If $P(X = 3) = 5P(X = 4)$, then the sum of the mean and the variance of X is :

- (A) $\frac{105}{16}$ (B) $\frac{7}{16}$
 (C) $\frac{77}{36}$ (D) $\frac{49}{16}$

Official Ans. by NTA (C)

Sol. $B(7, p)$

$$n = 7 \quad p = p$$

given

$$P(x = 3) = 5P(x = 4)$$

$${}^7C_3 \times p^3 (1-p)^4 = 5 \cdot {}^7C_4 p^4 (1-p)^3$$

$$\frac{{}^7C_3}{5 \times {}^7C_4} = \frac{p}{1-p}$$

$$1-p = 5p$$

$$6p = 1$$

$$p = \frac{1}{6} \Rightarrow q = \frac{5}{6}$$

$$n = 7$$

$$\text{Mean} = np = 7 \times \frac{1}{6} = \frac{7}{6}$$

$$\text{Var} = npq = 7 \times \frac{1}{6} \times \frac{5}{6} = \frac{35}{36}$$

Sum

$$= \frac{7}{6} + \frac{35}{36}$$

$$= \frac{42+35}{36}$$

$$= \frac{77}{36}$$

18. The value of $\cos\left(\frac{2\pi}{7}\right) + \cos\left(\frac{4\pi}{7}\right) + \cos\left(\frac{6\pi}{7}\right)$

is equal to :

(A) -1 (B) $-\frac{1}{2}$

(C) $-\frac{1}{3}$ (D) $-\frac{1}{4}$

Official Ans. by NTA (B)

Sol. $\cos \frac{2\pi}{7} + \cos \frac{4\pi}{7} + \cos \frac{6\pi}{7}$

$$= \frac{\sin\left(3 \times \frac{\pi}{7}\right)}{\sin \frac{\pi}{7}} \times \cos\left(\frac{\frac{2\pi}{7} + \frac{6\pi}{7}}{2}\right)$$

$$= \frac{2 \sin\left(\frac{3\pi}{7}\right)}{2 \sin \frac{\pi}{7}} \times \cos\left(\frac{4\pi}{7}\right)$$

$$= \frac{\sin\left(\frac{7\pi}{7}\right) + \sin\left(\frac{-\pi}{7}\right)}{2 \sin \frac{\pi}{7}}$$

$$= \frac{-\sin \frac{\pi}{7}}{2 \sin \frac{\pi}{7}}$$

$$= -\frac{1}{2}$$

19. $\sin^{-1}\left(\sin \frac{2\pi}{3}\right) + \cos^{-1}\left(\cos \frac{7\pi}{6}\right) + \tan^{-1}\left(\tan \frac{3\pi}{4}\right)$ is

equal to :

(A) $\frac{11\pi}{12}$ (B) $\frac{17\pi}{12}$

(C) $\frac{31\pi}{12}$ (D) $-\frac{3\pi}{4}$

Official Ans. by NTA (A)

Sol. $\sin^{-1}\left(\sin \frac{2\pi}{3}\right) + \cos^{-1}\left(\cos \frac{7\pi}{6}\right) + \tan^{-1} \tan\left(\frac{3\pi}{4}\right)$

$$\sin^{-1} \sin\left(\frac{2\pi}{3}\right) = \pi - \frac{2\pi}{3} = \frac{\pi}{3}$$

$$\cos^{-1}\left(\cos \frac{2\pi}{6}\right) = 2\pi - \frac{7\pi}{6} = \frac{5\pi}{6}$$

$$\tan^{-1} \tan\left(\frac{3\pi}{4}\right) = \frac{3\pi}{4} - \pi = \frac{-\pi}{4}$$

$$\sin^{-1}\left(\sin \frac{2\pi}{3}\right) + \cos^{-1} \cos \frac{7\pi}{6} + \tan^{-1} \tan \frac{3\pi}{4}$$

$$= \frac{11\pi}{12}$$

20. The Boolean expression $(\sim(p \wedge q)) \vee q$ is equivalent to :

- (A) $q \rightarrow (p \wedge q)$ (B) $p \rightarrow q$
 (C) $p \rightarrow (p \rightarrow q)$ (D) $p \rightarrow (p \vee q)$

Official Ans. by NTA (D)

Sol. $(\sim(p \wedge q)) \vee q$
 $= (\sim p \vee \sim q) \vee q$
 $= \sim p \vee \sim q \vee q$
 $= \sim p \vee t$
 $=$ this statement is a tautology option D
 $p \Rightarrow (p \vee q)$ is also a tautology.
 OR

p	q	$P \wedge q$	$\sim(p \wedge q)$	$\sim(p \wedge q) \vee q$	$P \vee q$	$p \rightarrow (p \vee q)$
T	T	T	F	T	T	T
T	F	F	T	T	T	T
F	T	F	T	T	T	T
F	F	F	T	T	F	T

SECTION-B

1. Let $f : R \rightarrow R$ be a function defined $f(x) = \frac{2e^{2x}}{e^{2x} + e}$.
 Then $f\left(\frac{1}{100}\right) + f\left(\frac{2}{100}\right) + f\left(\frac{3}{100}\right) + \dots + f\left(\frac{99}{100}\right)$ is equal to _____.

Official Ans. by NTA (99)

Sol.
 $f(x) + f(1-x) = \frac{2e^{2x}}{e^{2x} + e} + \frac{2e^{2-2x}}{e^{2-ex} + e} = \left[\frac{e^{2x}}{e^{2x} + e} + \frac{e^2}{e^2 + e^{2x+1}} \right]$
 $= 2 \left[\frac{e^{2x-1}}{e^{2x-1} + 1} + \frac{1}{1 + e^{2x-1}} \right] = 2$

$$f\left(\frac{1}{100}\right) + f\left(\frac{2}{100}\right) + f\left(\frac{3}{100}\right) + \dots + f\left(\frac{99}{100}\right)$$

$$= \left\{ f\left(\frac{1}{100}\right) + f\left(\frac{99}{100}\right) \right\} + \left\{ f\left(\frac{2}{100}\right) + f\left(\frac{98}{100}\right) \right\} + \dots + f\left\{ \left(\frac{49}{100}\right) + f\left(\frac{51}{100}\right) \right\} + f\left(\frac{1}{2}\right)$$

$$= (2 + 2 + 2 + \dots + 49 \text{ times}) + \frac{2e}{e+e}$$

$$= 98 + 1 = 99$$

2. If the sum of all the roots of the equation $e^{2x} - 11e^x - 45e^{-x} + \frac{81}{2} = 0$ is $\log_e P$, then p is equal to _____.

Official Ans. by NTA (45)

Sol. $e^{2x} - 11e^x - 45e^{-x} + \frac{81}{2} = 0$]
 $(e^x)^3 - 11(e^x)^2 - 45 + \frac{81e^x}{2} = 0$
 $e^x = t$
 $2t^3 - 22t^2 + 81t - 90 = 0$
 $t_1 t_2 t_3 = 45$
 $e^{x_1} \cdot e^{x_2} \cdot e^{x_3} = 45$
 $e^{x_1 + x_2 + x_3} = 45$
 $\log_e e^{x_1 + x_2 + x_3} = \log_e 45$
 $x_1 + x_2 + x_3 = \log_e 45$
 $\log_e P = \log_e 45$
 $P = 45$

3. The positive value of the determinant of the matrix A, whose $Adj(Adj(A)) = \begin{pmatrix} 14 & 28 & -14 \\ -14 & 14 & 28 \\ 28 & -14 & 14 \end{pmatrix}$, is _____.

Official Ans. by NTA (14)

Sol. $Adj(AdjA) = \begin{bmatrix} 14 & 18 & -14 \\ -14 & 14 & 28 \\ 28 & -14 & 14 \end{bmatrix}$

$$|Adj(AdjA)| = \begin{vmatrix} 14 & 28 & -14 \\ -14 & 14 & 28 \\ 28 & -14 & 14 \end{vmatrix} = 14 \times 14 \times 14 \begin{vmatrix} 1 & 2 & -1 \\ -1 & 1 & 2 \\ 2 & -1 & 1 \end{vmatrix}$$

$$= (14)^3 [3 - 2(-5) - 1(-1)] = (14)^3 [14] = (14)^4$$

$$|A|^4 = (14)^4 \Rightarrow |A| = 14$$

4. The number of ways, 16 identical cubes, of which 11 are blue and rest are red, can be placed in a row so that between any two red cubes there should be at least 2 blue cubes, is _____.

Official Ans. by NTA (56)

Sol. 16 cubes $\begin{cases} 11 \text{ Blue} \\ 5 \text{ Red} \end{cases}$

$$x_1 + x_2 + x_3 + x_4 + x_5 + x_6 = 11$$

$$x_1, x_6 \geq 0, \quad x_2, x_3, x_4, x_5 \geq 2$$

$$x_2 = t_1 + 2$$

$$x_3 = t_3 + 2$$

$$x_4 = t_4 + 2$$

$$x_5 = t_5 + 2$$

$$x_1, t_2, t_3, t_4, t_5, x_6 \geq 0$$

No. of solutions $= {}^{6+3-1} C_3 = {}^8 C_3 = 56$

5. If the coefficient of x^{10} in the binomial expansion of $\left(\frac{\sqrt{x}}{5^{\frac{1}{4}}} + \frac{\sqrt{5}}{x^{\frac{1}{3}}}\right)^{60}$ is $5^k l$, where $l, k \in \mathbb{N}$ and l is co-prime to 5, then k is equal to _____.

Official Ans. by NTA (5)

Sol. $\left(\frac{\sqrt{x}}{5^{\frac{1}{4}}} + \frac{\sqrt{5}}{x^{\frac{1}{3}}}\right)^{60}$

$$T_{r+1} = {}^{60} C_r \left(\frac{x^{1/2}}{5^{1/4}}\right)^{60-r} \left(\frac{5^{1/2}}{x^{1/3}}\right)^r$$

$$= {}^{60} C_r 5^{\frac{3r-60}{4}} \cdot x^{\frac{180-5r}{6}}$$

$$\frac{180-5r}{6} = 10 \Rightarrow r = 24$$

Coeff. of $x^{10} = {}^{60} C_{24} 5^3 = \frac{60}{24 \cdot 36} 5^3$

Powers of 5 in $= {}^{60} C_{24} \cdot 5^3 = \frac{5^{14}}{5^4 \times 5^8} \times 5^3 = 5^5$

6. Let $A_1 = \{(x, y) : |x| \leq y^2, |x| + 2y \leq 8\}$ and $A_2 = \{(x, y) : |x| + |y| \leq k\}$. If 27 (Area A_1) = 5 (Area A_2), then k is equal to :

Official Ans. by NTA (6)

Sol. $A_1 = \{(x, y) : |x| \leq y^2, |x| + 2y \leq 8\}$ and $A_2 = \{(x, y) : |x| + |y| \leq k\}$.

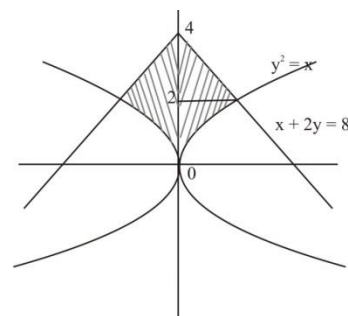

$$\text{area}(A_1) = 2 \left[\int_0^2 y^2 dy + \int_2^4 (8-2y) dy \right]$$

$$= 2 \left[\left(\frac{y^3}{3} \right)_0^2 + (8y - y^2)_2^4 \right]$$

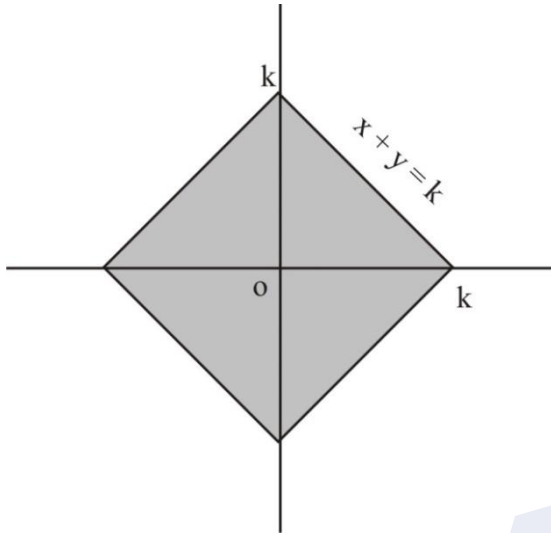

$$\text{area}(A_1) = 2 \times \frac{20}{3} = \frac{40}{3}$$

$$\text{Area}(A_2) = 4 \times \frac{1}{2} k^2$$

$$\text{Area}(A_2) = 2k^2$$

Now

$$27 (\text{Area } A_1) = 5 (\text{Area } A_2)$$

$$9 \times 4 = k^2$$

$$k = 6$$

7. If the sum of the first ten terms of the series

$$\frac{1}{5} + \frac{2}{65} + \frac{3}{325} + \frac{4}{1025} + \frac{5}{2501} + \dots \text{ is } \frac{m}{n}, \text{ where}$$

m and n are co-prime numbers, then m + n is equal to _____.

Official Ans. by NTA (276)

Sol.
$$\frac{1}{5} + \frac{2}{65} + \frac{3}{325} + \frac{4}{1025} + \frac{5}{2501} + \dots$$

$$T_n = \frac{n}{4n^4 + 1}$$

$$= \frac{n}{(2n^2 + 1)^2 - (2n)^2} = \frac{n}{(2n^2 + 2n + 1)(2n^2 - 2n + 1)}$$

$$= \frac{1}{4} \left[\frac{1}{2n^2 - 2n + 1} - \frac{1}{2n^2 + 2n + 1} \right]$$

$$S_{10} = \sum_{n=1}^{10} T_n = \frac{1}{4} \left[\frac{1}{1} - \frac{1}{5} + \frac{1}{5} - \frac{1}{13} + \dots + \frac{1}{200 + 20 + 1} \right]$$

$$= \frac{1}{4} \left[1 - \frac{1}{221} \right] = \frac{1}{4} \times \frac{220}{221} = \frac{55}{221} = \frac{m}{n}$$

$$m + n = 55 + 221 = 276$$

8. A rectangle R with end points of the one of its sides as (1, 2) and (3, 6) is inscribed in a circle. If the equation of a diameter of the circle is $2x - y + 4 = 0$, then the area of R is _____.

Official Ans. by NTA (16)

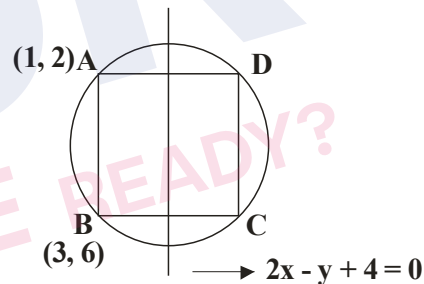

Sol.

Eq. of line AB

$$y = 2x$$

$$\text{Slope of AB} = 2$$

$$\text{Slope of given diameter} = 2$$

So the diameter is parallel to AB

Distance between diameter and line AB

$$= \left(\frac{4}{\sqrt{2^2 + 12}} \right) = \frac{4}{\sqrt{5}}$$

$$\text{Thus BC} = 2 \times \frac{4}{\sqrt{5}} = \frac{8}{\sqrt{5}}$$

$$AB = \sqrt{(1-3)^2 + (2-6)^2} = \sqrt{20} = 2\sqrt{5}$$

$$\text{Area} = AB \times BC = \frac{8}{\sqrt{5}} \times 2\sqrt{5} = 16 \text{ Ans.}$$

9. A circle of radius 2 unit passes through the vertex and the focus of the parabola $y^2 = 2x$ and touches the parabola $y = \left(x - \frac{1}{4}\right)^2 + \alpha$, where $\alpha > 0$.
 Then $(4\alpha - 8)^2$ is equal to _____.

Official Ans. by NTA (63)

Sol. Vertex and focus of parabola $y^2 = 2x$ are V (0, 0) and S $\left(\frac{1}{2}, 0\right)$ resp.

Let equation of circle be

$$(x - h)^2 + (y - k)^2 = 4$$

\therefore Circle passes through (0, 0)

$$\Rightarrow h^2 + k^2 = 4 \dots\dots(1)$$

\therefore Circle passes through $\left(\frac{1}{2}, 0\right)$

$$\left(\frac{1}{2} - h\right)^2 + k^2 = 4$$

$$\Rightarrow h^2 + k^2 - h = \frac{15}{4} \dots\dots(2)$$

On solving (1) and (2)

$$4 - h = \frac{15}{4}$$

$$h = 4 - \frac{15}{4} = \frac{1}{4}$$

$$k = +\frac{\sqrt{63}}{4}$$

$k = -\frac{\sqrt{63}}{4}$ is rejected as circle with centre

$\left(\frac{1}{4}, -\frac{\sqrt{63}}{4}\right)$ can't touch given parabola.

Equation of circle is

$$\left(x - \frac{1}{4}\right)^2 + \left(k - \frac{\sqrt{63}}{4}\right)^2 = 4$$

From figure

$$\alpha = 2 + \frac{\sqrt{63}}{4} = \frac{8 + \sqrt{63}}{4}$$

$$4\alpha - 8 = \sqrt{63}$$

$$(4\alpha - 8)^2 = 63$$

10. Let the mirror image of the point (a, b, c) with respect to the plane $3x - 4y + 12z + 19 = 0$ be (a - 6, β , γ). If $a + b + c = 5$, then $7\beta - 9\gamma$ is equal to _____.

Official Ans. by NTA (137)

Sol.

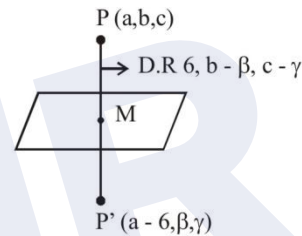

$$M = \left(a - 3, \frac{\beta + b}{2}, \frac{\gamma + c}{2}\right)$$

Since M lies on $3x + 4y + 12z + 19 = 0$

$$\Rightarrow 6a - 4b + 12c - 4\beta + 12\gamma + 20 = 0 \dots(1)$$

Since PP' is parallel to normal of the plane then

$$\frac{6}{3} = \frac{b - \beta}{-4} = \frac{c - \gamma}{12}$$

$$\Rightarrow \beta = b + 8, \quad \gamma = c - 24$$

$$a + b + c = 5 \Rightarrow a + \beta - 8 + \gamma + 24 = 5$$

$$\Rightarrow a = -\beta - \gamma - 11$$

Now putting these values in (1) we get

$$6(-\beta - \gamma - 11) - 4(\beta - 8) + 12(\gamma + 24) - 4\beta + 12\gamma + 20 = 0$$

$$\Rightarrow 7\beta - 9\gamma = 170 - 33 = 137$$